

# G855 & GTA855

## Gas Compression Applications

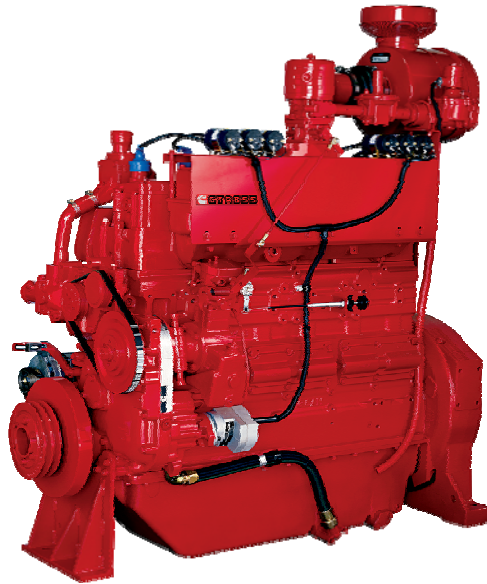

The demands of wellhead and gathering compression applications require an engine that is reliable and durable. For dependable operations and world class support, you need the Cummins G855 and GTA855 – a high-performance natural gas engine that shares the proven heritage of the Cummins diesel engines and many of the same heavy-duty components. You can depend on Cummins engines to keep maintenance costs down and the gas flowing. Every day.

### General Specifications

#### Inline 6-cylinder, 4-Cycle, Natural Gas

Bore	5.5 in (140 mm)
Stroke	6.0 in (152 mm)
Displacement	14.0 L (855 cubic in)
Engine Power*	157-286 hp (117-213 kW)
Compression Ratio	NA: 10:1 TA: 8.5:1
Aspiration	Naturally aspirated or turbocharged aftercooled
Exhaust Type	Watercooled manifold
Weight**	2970 lb (1347 kg)
Coolant Capacity	5.5 gal (20.8 L)
Lube Oil Capacity	15.0 gal (57.0 L)
Rotation	Counterclockwise

\* Rating dependent

\*\* Weight is approximate and varies with options.

### Features

Designed for the oil and gas market, the G855 and GTA855 deliver exceptional dependability and low cost of operation.

**Base Engine** – Most major components, including block, crank, cam, gears and liners are common with the proven N series diesel.

**Emissions** – The G855 and GTA855 have catalyst ratings available to allow the engine to be operated as a rich burn engine and can be customer equipped with an AFR and catalyst to meet NSPS emissions requirements. The GTA855 also has export only ratings available.

**Air Handling** – The naturally aspirated G855 and turbocharged and aftercooled GTA855 deliver reliable performance and life.

**Fuel System** – Impco carburetor provides stable operation and fuel tracking through all load ranges.

**Speed Control** – Adjustable pressure-compensated hydraulic governor provides precise and stable rpm control under all load conditions.

**Ignition System** – Altronic V integral electronic ignition system with easily accessible spark plug location and single coil per cylinder for lower maintenance costs.

**Lubrication System** – High-capacity oil pan and combination full-flow and bypass oil filter reduces maintenance costs and extend service intervals.

**Warranty** – Cummins one year, unlimited hours. Backed by a worldwide distributor network.

# Rating Details.

Model	Curve Number	Rating	Emissions	Combustion
G855	FR-10523	157 hp @ 1500 rpm	(1)	Rich
G855	FR-10526	188 hp @ 1800 rpm	(1)	Rich
GTA855	FR-10688	225 hp @ 1800 rpm	(1)	Rich
GTA855	FR-10533	256 hp @ 1800 rpm	Export Only	Standard
GTA855	FR-10531	281 hp @ 1800 rpm	Export Only	Standard
GTA855	FR-10529	286 hp @ 1800 rpm	Export Only	Standard
GTA855	FR-10539	213 hp @ 1500 rpm	Export Only	Standard
GTA855	FR-10537	234 hp @ 1500 rpm	Export Only	Standard
GTA855E	FR-10535	238 hp @ 1500 rpm	Export Only	Standard

(1) NSPS compliant with customer installed Air-fuel ratio (AFR) controller and catalyst.

\* Requires EPA site validation testing.

## Standard Equipment.

### Air Inlet System

- Factory installed heavy duty air cleaner

### Cooling System

- Two pump / two loop cooling system – GTA855
- Gear driven jacket water pump
- Gear driven auxiliary coolant pump – GTA855
- Thermostat controlled jacket water circuit
- Coolant filter for added corrosion protection
- Auxiliary coolant pump optional for compressor cooling - G855

### Exhaust System

- Watercooled manifold

### Fuel System

- Impco carburetor
- Maxitrol regulator

### Speed Control System

- Gear driven Woodard hydraulic / mechanical governor
- Electronic governor optional

### Ignition System

- Altronic V ignition system
- Altronic III ignition system optional
- Altronic V shielded ignition optional
- Altronic III shielded ignition optional

### Lube Oil System

- Crankcase breather
- High capacity oil pan for extended oil drain intervals
- Combination full flow and bypass oil filter

### Safety Shutoff Protection

- Electric fuel valve

### Mounting Arrangement

- Front and rear engine mounting
- Lift provisions on engine

### Flywheel and Flywheel Housing

- Flywheel SAE #1
- Flywheel housing – SAE #1 Cast-iron, machined to accommodate starter mounting

### Electrical System

- 24-volt alternator

### Starting System

- 24-volt starter
- Gas starter optional

### Power Take-Off

- Front crankshaft pulley

# Engine Technical Data.

Model		G855	GTA855	GTA855
<b>Curve Number</b>		FR-10523 (2)	FR-10688 (2)	FR-10529 (2)
<b>Exhaust Type</b>		Dry Manifold	Wet Manifold	Wet Manifold
<b>Output Power (1)</b>				
100%	HP (kW)	188 (140)	225 (168)	286 (213)
75%	HP (kW)	141 (105)	169 (126)	215 (160)
<b>Engine Speed</b>				
100%	RPM	1800	1800	1800
Max Turn Down	RPM	1350	1350	1350
<b>After-Cooler Water Inlet Temperature</b>				
	°F (°C)	N/A	130 (54.4)	130 (54.4)
<b>Compression Ratio</b>				
		10:1	8.5:1	8.5:1
<b>Emissions Data – Engine-Out Emissions (1)</b>				
NOx	g/hp-hr (g-kW-hr)	5.9 (7.91)	12.1 (16.23)	7.6 (10.2)
CO	g/hp-hr (g-kW-hr)	26.7 (35.81)	2.9 (3.89)	1.1 (1.48)
NMHC	g/hp-hr			
THC	g/hp-hr	1.90	1.43	0.52
O <sub>2</sub>	%	0.54	0.41	4.20
<b>Fuel Consumption (1)</b>				
100%	BTU/hp-hr (MJ/kW-hr)	8605 (12.2)	8478 (12.0)	8224 (11.6)
75%	BTU/hp-hr (MJ/kW-hr)	9870 (14.0)	9077 (12.8)	8631 (12.2)
<b>Heat Rejection (1)</b>				
Jacket Water	BTU/min (kW)	8154 (143.38)	11445 (201.3)	12677 (223)
After-cooler	BTU/min (kW)	N/A	807 (14.19)	1902 (33.5)
Exhaust	BTU/min (kW)	5674 (99.77)	8137 (143.08)	11792 (207.4)
<b>Exhaust System (1)</b>				
Flow Rate	ft <sup>3</sup> /min (L/s)	866 (409)	945 (446)	1851 (874)
Stack temp	°F (°C)	1196 (647)	1304 (707)	1337 (725)
Max Back Pres.	in-Hg	2	2	2
<b>Intake System (1)</b>				
Flow Rate	ft <sup>3</sup> /min (L/s)	260 (123)	411 (194)	605 (286)
Max Restriction	in-H <sub>2</sub> O	15	15	15
<b>Gas Pressure</b>				
Min - Max	psi	10-20	10-20	10-20

# General Dimensions.

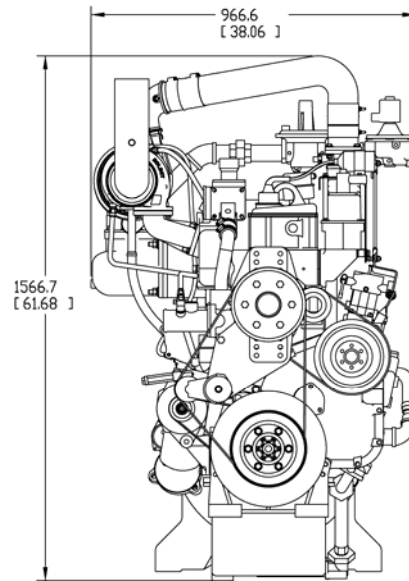
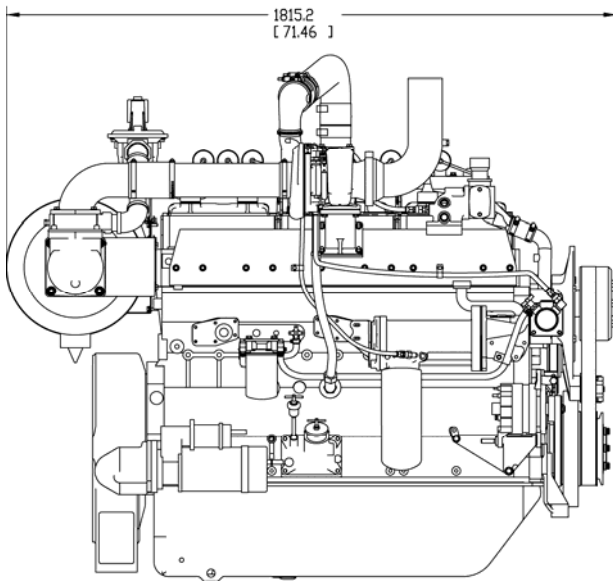

Turbocharged model pictured above

Dimensions*		NA	TA
Length	Inches (mm)	67.7 (1718)	71.5 (1815)
Width	Inches (mm)	35.9 (912)	38.1 (966)
Height	Inches (mm)	53.9 (1368)	61.7 (1567)

\* Dimensions are approximate and vary with options.

## Disclaimers.

(2) All data is based on the engine operating with fuel system, water pump, and 8 in H<sub>2</sub>O (1.991 kPa) inlet air restriction with 5 in (127 mm) inner diameter, and with 1.1 in Hg (4 kPa) exhaust restriction with 4 in (102 mm) inner diameter; not included are alternator, fan, optional equipment and driven components. Coolant flows and heat rejection data based on coolants as 50% ethylene glycol/50% water. All data is subject to change without notice.



Cummins Inc.  
 Box 3005  
 Columbus, IN 47202-3005  
 U.S.A.

Phone: 1-800-343-7357  
 Fax: 1-812-232-6393  
 Internet: [www.CumminsOilandGas.com](http://www.CumminsOilandGas.com)

Rev 10/09  
 ©2009 Cummins Inc.