

GET MORE DONE.

QSF3.8 VALUEPAK

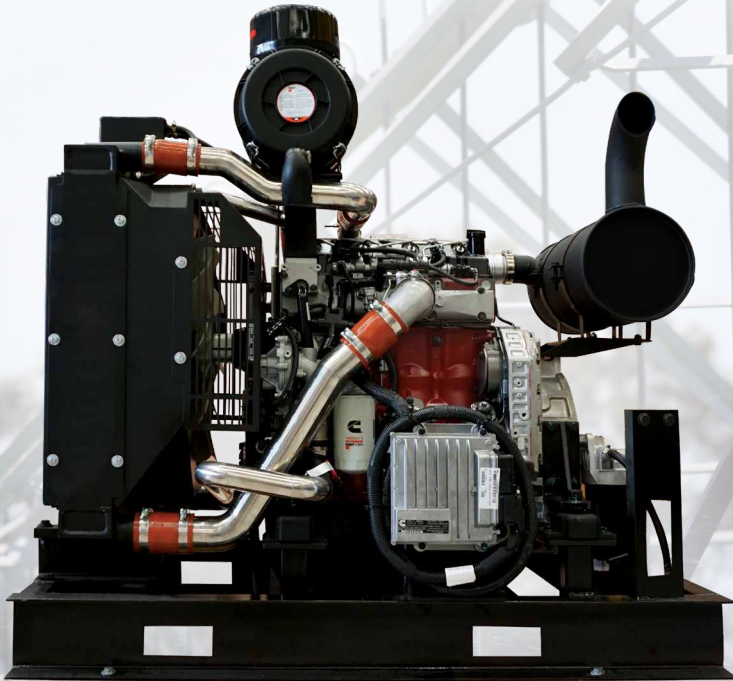

SPECIFICATIONS

Type	Four-stroke Cycle, Turbocharged, Charge Air Cooled, Inline 4 Cylinder Diesel Engine	
	US STD	METRIC
Power Rating	140 BHP	104 kW
Rated Speed	2200 RPM	2200 RPM
Peak Torque	398 lb ft	540 Nm
Peak Torque RPM	1320 RPM	1320 RPM
Bore & Stroke	4 in x 4.53 in	102 mm x 115 mm
Piston Displacement	57 cu in	3.8 L
Oil System Capacity	12.7 qt	12 Ltr
ValuePAK Coolant Capacity	4.7 US gal	18 Ltr
Engine Weight (Wet)	739 lb	335 kg
CustomPAK Weight (Wet)	1135 lb	515 kg



**FOR
A WORLD
THAT'S
ALWAYS ON™**

SCHEMATICS

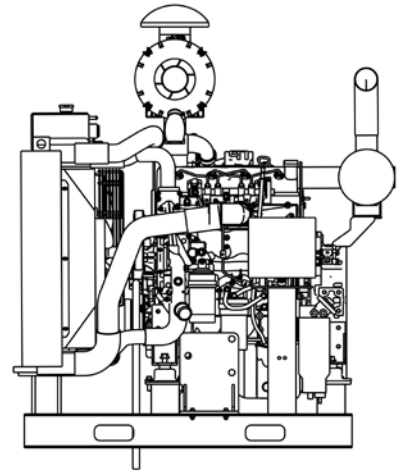
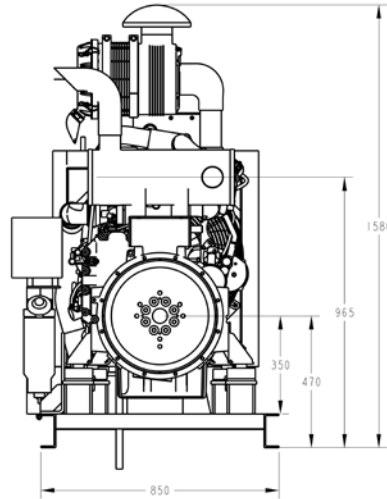
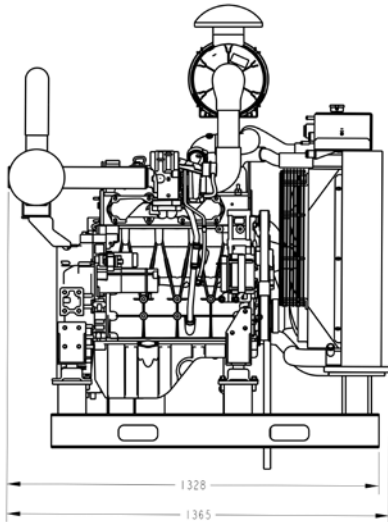
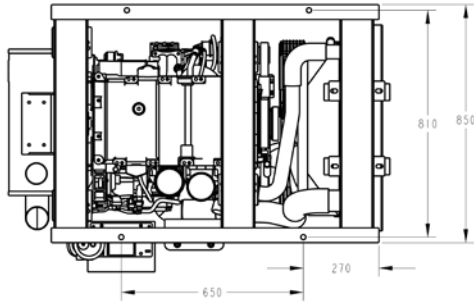

PERFORMANCE

RPM	Power output intermittent		Torque output intermittent		Power output continuous		Torque output continuous	
	hp	kW	lb-ft	N-m	hp	kW	lb-ft	N-m
800	36	27	237	321	36	27	237	321
900	48	36	279	378	46	34	269	365
1100	76	57	363	492	65	48	310	420
1300	99	74	398	540	77	57	310	420
1500	114	85	398	540	88	66	310	420
1700	129	96	398	540	99	74	300	407
1800	136	102	398	540	99	74	290	393
1900	138	103	381	516	99	74	274	372
2100	140	104	350	475	99	74	249	337
2200	140	104	334	453	99	74	237	321

* Note: no continuous rating available at these speeds.

KEY FEATURES

- **EU Stage IIIa Certified**
- **Full Authority Electronic Controls -**
Electronic control system provides engine control and monitoring for superior performance, fuel economy and diagnostics.
- **Bosch High Pressure -**
Common rail fuel system operating at 1600 Bar with full authority electronic control.
- **Air Cleaner -**
Single heavy duty industrial air cleaner, with safety element.
- **Baserail Mounting -**
Heavy section base frame.
- **Cooling System -**
Heavy duty, 50deg ambient capable radiator assembly, incorporating charge air cooler. Blower fan configuration as standard.
- **Exhaust -**
Muffler is included.
- **500 Hour Service Interval**

WARRANTY COVERAGE

Cummins base Engine coverage is 2 years or 2,000 hours of operation, or 1 year/unlimited hours of operation, whichever comes first.

All components of the QSF3.8 - ValuePAK which were purchased from Cummins South Pacific as a packaged product have the same Base Engine Warranty coverage as the Engine.

Extended Engine Major Components coverage is 3 years or 10,000 hours of operation, whichever occurs first.

Conditions apply. Full warranty details can be found in the Industrial Cummins Warranty brochure (Bulletin 3381322).

THE CUMMINS CARE EXPERIENCE

- At your service. 24 hours a day, 365 days a year.
- Unmatched factory-owned service support network with 35 Cummins branches and more than 150 authorised dealers across the South Pacific region.
- At the heart of our service operation is the Cummins Support Centre which boasts a team of highly experienced service technicians who will keep you Always On.

BREAKDOWN AND DIAGNOSTIC SUPPORT PRODUCT AND SERVICE

TECHNICAL SUPPORT

PARTS ORDERING

DIGITAL PRODUCTS
& SERVICES

CONNECTED PRODUCT SUPPORT



CARE.CUMMINS.COM

Access our extensive knowledge database, download data sheets, perform an advanced search of our website and use the contact form to email us.



EMAIL

1300cummins@cummins.com

Email allows users to connect with agents online in a multitude of languages.



For Australia

1300Cummins
Ph 1300 286 646

For New Zealand

0800Cummins
Ph 0800 286 646

To speak directly with the Cummins Care team for breakdown support, parts orders, product inquiries, diagnostic and one-on-one technical support, 24 hours a day 365 days a year.



For more information
scan here



Cummins Head Office
2 Caribbean Drive
Scoresby VIC 3179
Australia

cummins.com

QPR1076 Produced in Australia. 8/22
©2022 Cummins South Pacific Pty Ltd.