

Revision: A.16
 STATE: Engineering Released
 EXPORT_CONTROL: HARD_WARE=EAR - EAR99, EXPORT_CONTROL=EAR - EAR99

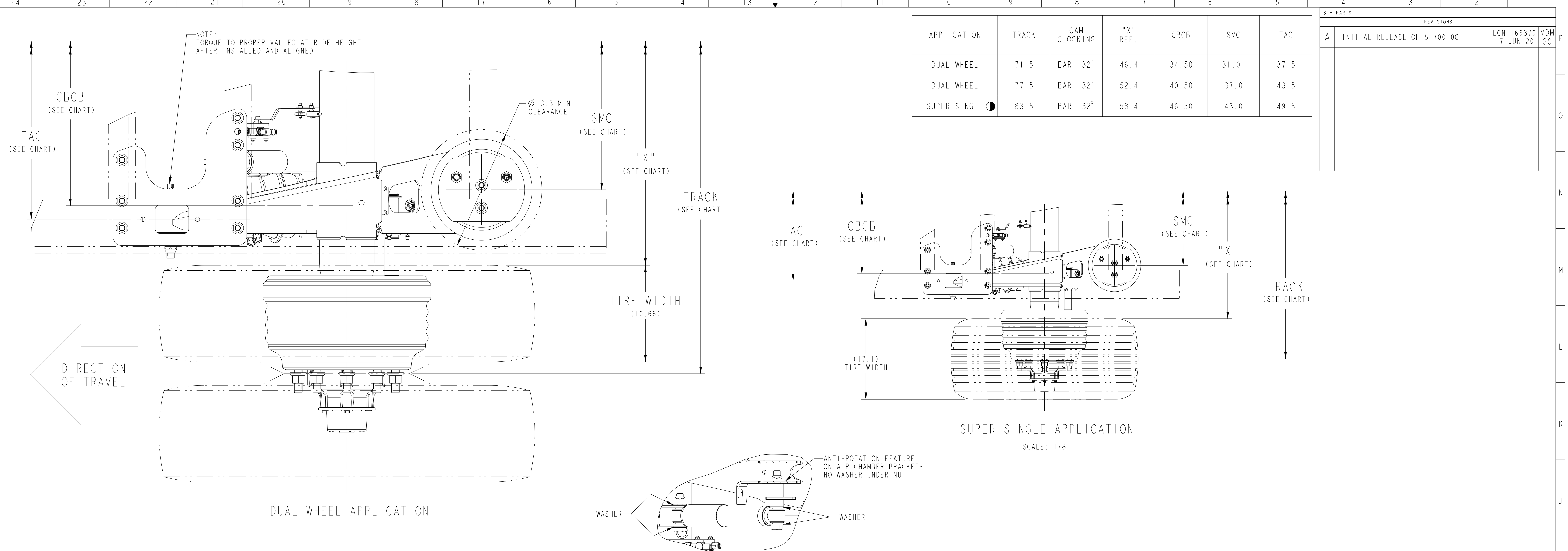

APPLICATION	TRACK	CAM CLOCKING	"X" REF.	CBCB	SMC	TAC
DUAL WHEEL	71.5	BAR 132°	46.4	34.50	31.0	37.5
DUAL WHEEL	77.5	BAR 132°	52.4	40.50	37.0	43.5
SUPER SINGLE	83.5	BAR 132°	58.4	46.50	43.0	49.5

SIM. PARTS		REVISIONS	
A	INITIAL RELEASE OF 5-70010G	ECN-166379 17-JUN-20	MDM SS

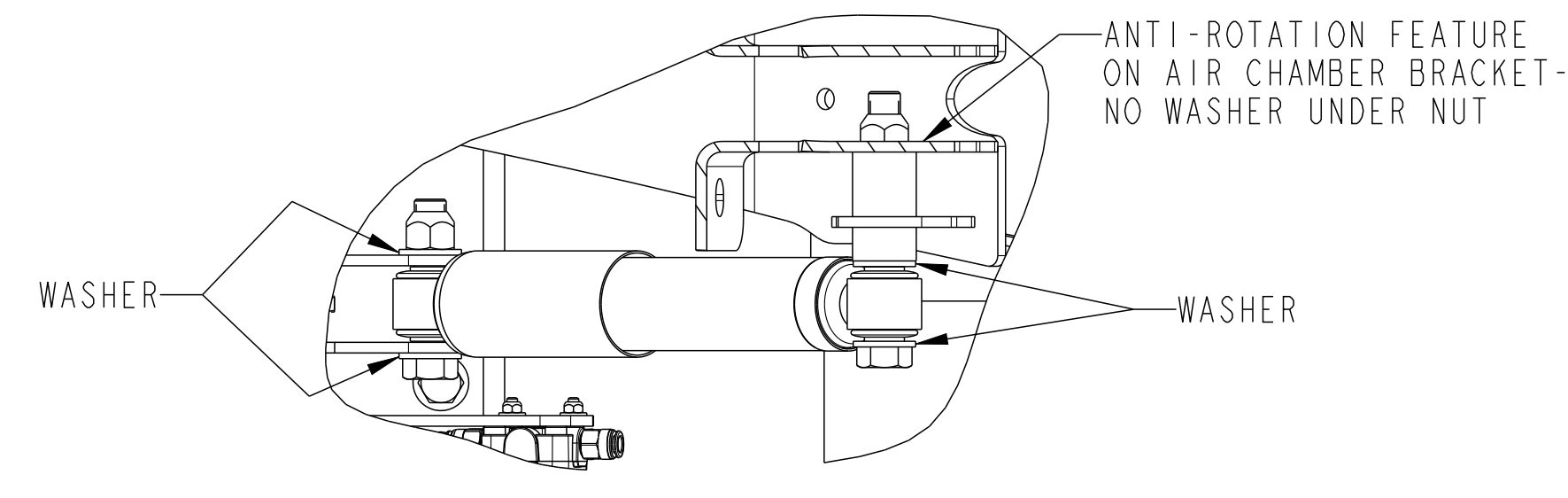

TYPICAL SHOCK INSTALLATION
 (AIR CHAMBER REMOVED FOR CLARITY)

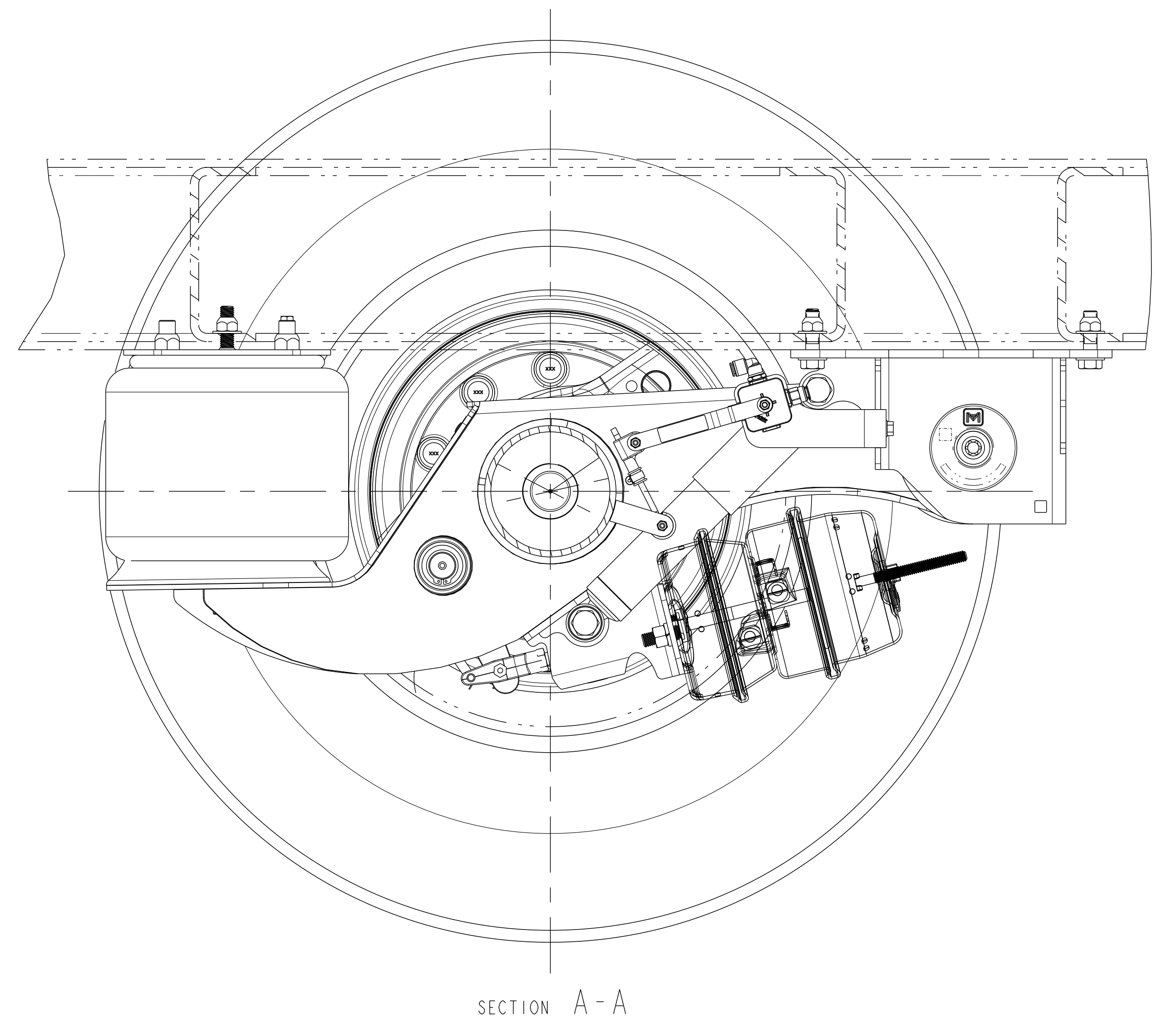
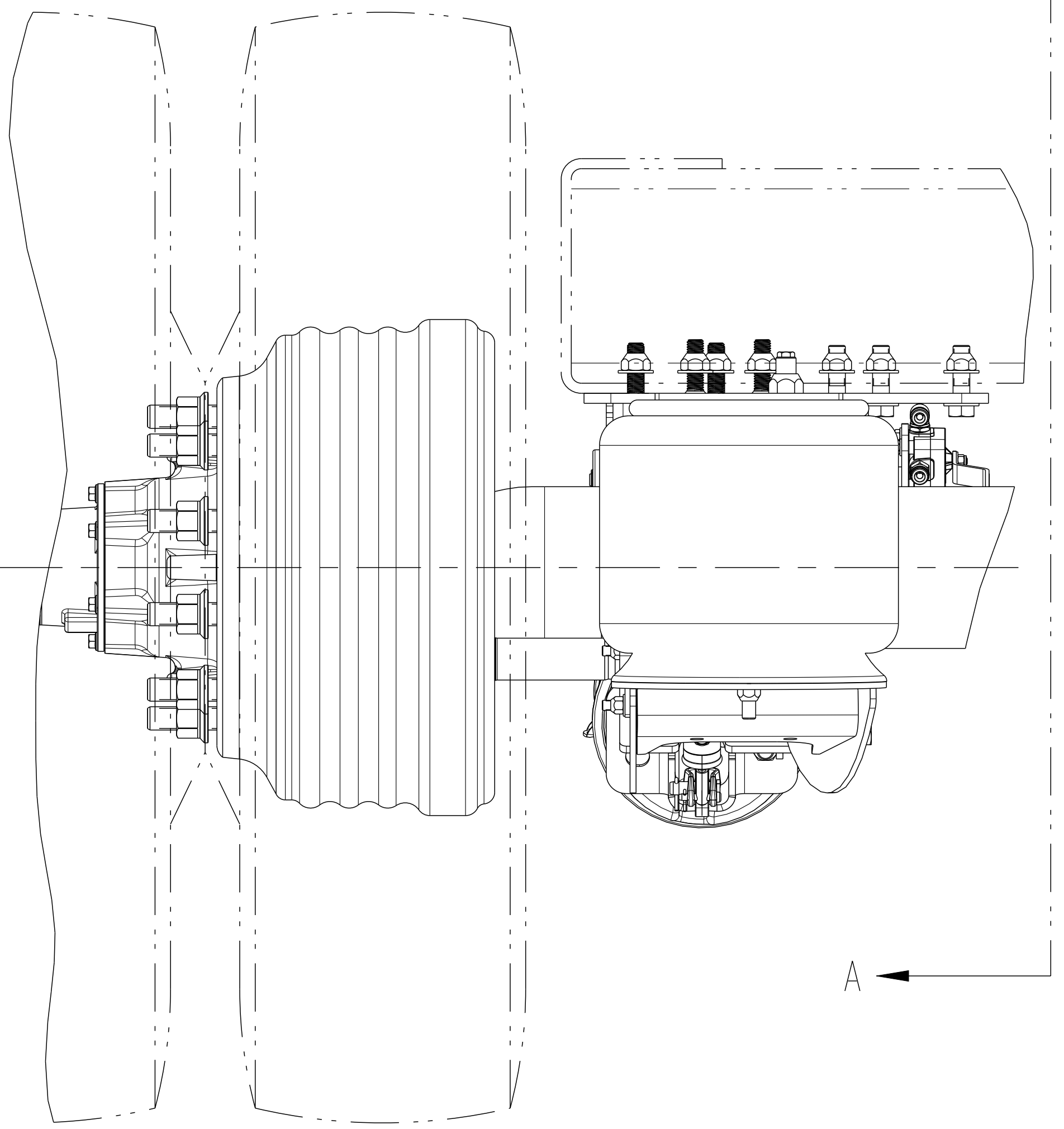
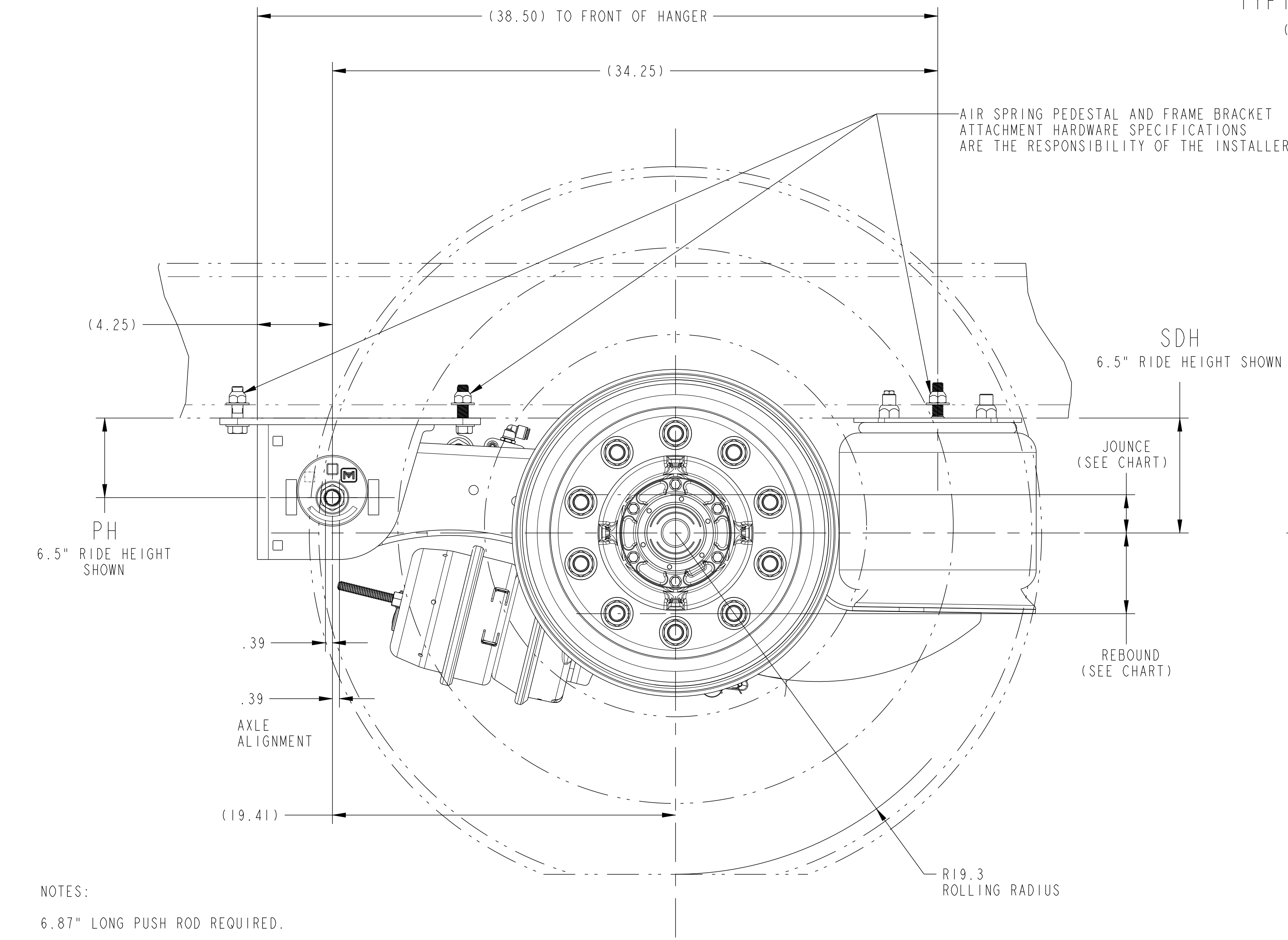

NOTES:
 6.87" LONG PUSH ROD REQUIRED.
 PROPER VEHICLE FRAME DESIGN IN THE AREA OF SUSPENSION ATTACHMENT IS THE RESPONSIBILITY OF THE INSTALLER.
 SUSPENSION SERIES: MTA-Tec6-23L
 SUSPENSION STATIC DESIGN CAPACITY = 23,000 LBS.
 RATING BASED ON APPLICATION APPROVAL.
 RATINGS FOR THE COMPONENTS WITHIN AN INDIVIDUAL MERITOR SUPPLIED SUSPENSION ASSEMBLY, INCLUDING BRAKES, HUBS, AND BEARINGS, MAY VARY AND MAY NOT BE EQUAL TO THE NOMINAL SUSPENSION RATING.
 NO WELDING OR DRILLING ALLOWED ON TRAILING ARMS.
 NO WELD WITHIN .25" OF FRAME BRACKET TOOLING HOLES.

PH	SDH	RISE HEIGHT	JOUNCE AT BUMPER CONTACT	REBOUND
4.5	6.5	6.5"	1.75	4.98
4.5	7.5	7.5"	2.75	3.98
4.5	8.0	8"	3.25	5.0
4.5	9.0	9"	4.25	4.0
8.0	13.5	12"	4.64	4.5
10.0	14.0	14"	5.02	4.5
10.0	15.0	15"	4.91	3.5
12.0	16.0	16"	5.02	4.5
12.0	17.0	17"	5.29	3.5

FOR FINAL INSTALLATION TO TRAILER REFER TO 5-69116A
 REFER TO SHOP CHART 4-60559_43 FOR TORQUE INFORMATION
 DATA BASED ON:
 DUAL TIRE SIZE: 11R22.5
 WHEEL OFFSET: .62
 SINGLE: TIRE SIZE 445/50R22.5
 WHEEL OFFSET: .56

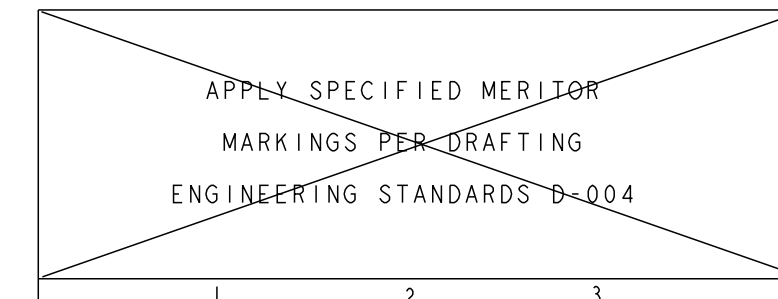

THIS PRINT IS LOANED ON A CONFIDENTIAL BASIS SUBJECT TO RETURN UPON DEMAND BY MERITOR AND NOTHING HEREON MAY BE REPRODUCED, USED OR DISCLOSED IN WHOLE OR IN PART WITHOUT THE PRIOR WRITTEN PERMISSION OF MERITOR.

SEE BILL OF MATERIAL FOR SPECIFIC INDIVIDUAL MODEL INFORMATION

ECN-166379	PART/DWG NO. 5-70010G	04627
RELEASE	NAME MTA-TEC6-23L SERIES GROUP	ENG. DESG. CODE
DRAWING SIZE E	MERITOR	INCH
DRAWING 5-70010G A.16	MODEL 5-70010G A.14	SHEET 1 OF 1

DO NOT CHANGE MANUALLY