



# Installation Manual

## Onan Generator Set for Commercial Mobile

HDKAL (Spec B–J)

HDKAS (Spec B–F)



# Table of Contents

---

SAFETY PRECAUTIONS .....	III
SPECIFICATIONS .....	V
INTRODUCTION .....	VII
ABOUT THIS MANUAL .....	vii
OUTLINE DRAWING AND FLOOR TEMPLATE .....	vii
INSTALLATION CODES AND STANDARDS FOR SAFETY .....	vii
MANUFACTURING FACILITIES .....	vii
LOCATION, ENCLOSURE AND MOUNTING .....	IX
VENTILATION AND COOLING .....	XI
Pusher fan applications .....	xi
Suction fan applications .....	xii
Cooling system test .....	xiii
EXHAUST CONNECTIONS .....	XV
Muffler .....	xv
Tailpipe .....	xvi
FUEL SUPPLY .....	XIX
Bio-diesel Fuels B5 – B20 .....	xxi
ELECTRICAL CONNECTIONS .....	XXIII
Generator set Connections .....	xxiii
Remote control connections .....	xxiv
REMOTE MOUNTING CONTROL BOX .....	xxv
Battery connections .....	xxvi
VOLTAGE ADJUSTMENTS .....	XXIX
INSTALLATION CHECKS AND STARTUP .....	XXXI
GENSET OUTLINE DRAWING .....	1
GENSET FLOOR TEMPLATE—PLAN VIEW .....	2
DC CONTROL DIAGRAMS .....	3
SINGLE-PHASE AC DIAGRAMS .....	4
THREE-PHASE AC DIAGRAMS .....	5

# Safety Precautions

---

Thoroughly read the **OPERATOR'S MANUAL** before operating the generator set set. Safe operation and top performance can be obtained only by proper operation and maintenance.

The following symbols in this Manual alert you to potential hazards to the operator, service personnel and equipment.

**⚠ DANGER** alerts you to an immediate hazard which will result in severe personal injury or death.

**⚠ WARNING** **⚠ WARNING** alerts you to a hazard or unsafe practice which can result in severe personal injury or death.

**⚠ CAUTION** alerts you to a hazard or unsafe practice which can result in personal injury or equipment damage.

Electricity, fuel, exhaust, moving parts and batteries present hazards which can result in severe personal injury or death.

## GENERAL PRECAUTIONS

- Keep ABC fire extinguishers handy.
- Make sure all fasteners are secure and torqued properly.
- Keep the generator set set and its compartment clean. Excess oil and oily rags can catch fire. Dirt and gear stowed in the compartment can restrict cooling air.
- Let the engine cool down before removing the coolant pressure cap or opening the coolant drain. Hot coolant under pressure can spray out and cause severe burns.
- Before working on the generator set set, disconnect the negative (-) battery cable at the battery to prevent starting.
- Use caution when making adjustments while the generator set set is running—hot, moving

or electrically live parts can cause severe personal injury or death.

- Used engine oil has been identified by some state and federal agencies as causing cancer or reproductive toxicity. Do not ingest, inhale, or contact used oil or its vapors.
- Do not work on the generator set set when mentally or physically fatigued or after consuming alcohol or drugs.
- Carefully follow all applicable local, state and federal codes.

## GENERATOR SET VOLTAGE IS DEADLY!

- generator set output connections must be made by a qualified electrician in accordance with applicable codes.
- The generator set set must not be connected to the public utility or any other source of electrical power. Connection could lead to electrocution of utility workers, damage to equipment and fire. An approved switching device must be used to prevent interconnections.
- Use caution when working on live electrical equipment. Remove jewelry, make sure clothing and shoes are dry and stand on a dry wooden platform on the ground or floor.

## FUEL IS FLAMMABLE AND EXPLOSIVE

- Keep flames, cigarettes, sparks, pilot lights, electrical arc-producing equipment and switches and all other sources of ignition well away from areas where fuel fumes are present and areas sharing ventilation.
- Fuel lines must be secured, free of leaks and separated or shielded from electrical wiring.
- Use approved non-conductive flexible fuel hose for fuel connections at the generator set set.

## ENGINE EXHAUST IS DEADLY!

- Learn the symptoms of carbon monoxide poisoning in this manual.
- Never sleep in the vehicle while the generator set set is running unless the vehicle has a working carbon monoxide detector.
- The exhaust system must be installed in accordance with the generator set set Installation Manual.
- Do not use engine cooling air to heat the vehicle interior.
- Make sure there is ample fresh air when operating the generator set set in a confined area.

## MOVING PARTS CAN CAUSE SEVERE PERSONAL INJURY OR DEATH

- Do not wear loose clothing or jewelry near moving parts such as PTO shafts, fans, belts and pulleys.
- Keep hands away from moving parts.
- Keep guards in place over fans, belts, pulleys, etc.

## BATTERY GAS IS EXPLOSIVE

- Wear safety glasses and do not smoke while servicing batteries.
- When disconnecting or reconnecting battery cables, always disconnect the negative (-) battery cable first and reconnect it last to reduce arcing.

## DO NOT OPERATE IN FLAMMABLE AND EXPLOSIVE ENVIRONMENTS

Flammable vapor can cause a diesel engine to overspeed and become difficult to stop, resulting in possible fire, explosion, severe personal injury and death. ***Do not operate a diesel-powered generator set set where a flammable vapor environment can be created by fuel spill, leak, etc., unless the generator set set is equipped with an automatic safety device to block the air intake and stop the engine.*** The owners and operators of the generator set set are solely responsible for operating the generator set set safely. Contact your authorized Cummins dealer or distributor for more information.

# Specifications

---

## Control System

- Unit Mounted, Drip-Proof, Vibration Isolated Console
- **DC Controls - 12-Volt System**
  - Start/Stop/Preheat Switch
  - Sealed Remote Connector for Start/Stop/Preheat Switch Gauge Package
  - Manual Reset Fault Relay Indicating Engine Shutdown for High Coolant Temperature, Low Oil Pressure
- **AC Controls**
  - Voltage Regulator (See generator set Detail)
  - One or Two Circuit Breakers

## Engine Detail

**Design:** 4-Cycle, Liquid-cooled Diesel Engine

**Cylinders:** Inline Vertical - 3

**Bore:**

HDKAL 3.07 in (78 mm)

HDKAS 2.83 IN (72 mm)

**Stroke:**

HDKAL 3.09 in 78.4 mm

HDKAS 2.90 in (73.6 mm)

**Displacement**

HDKAL 68.53 in<sup>3</sup> (1124 cm<sup>3</sup>)

HDKAS 54.8 in<sup>3</sup> (898 cm<sup>3</sup>)

**Compression Ratio:** 24 to 1

**Lube Oil Capacity:** 5.39 qt (5.1 L) Including Filter

**Cooling System Capacity:** 1.25 gal (4.73 L)

**Starting System:** Remote, 12-volt

**Fuel Injection Pump:** Bosch K mini

**Combustion Chamber:** Spherical

**Fuel Consumption:** No. 2 Diesel Fuel, gph/lph

	No Load	Half Load	Full Load
HDKAL	0.24 gph	0.49 gph	0.85 gph
	0.90 lph	1.85 lph	3.2 lph
HDKAS	0.23 gph	0.46 gph	0.8 gph
	0.87 lph	1.74 lph	3.03 lph

## generator set Detail

**Design:** Brush type, Drip-proof Construction.

**Insulation System Rise:** Class F per NEMA MGI-1.65 and BS 2757 Insulating Varnish Conforms to MIL-1-24092, Grade CB, Class 155 C.

**Exciter System:** Electronic Voltage Regulator

**Bearing:** Double Sealed Prelubricated Ball Bearing

**Cooling:** Direct Drive Centrifugal Blower

**Damper Bar:** Improves Harmonics and Voltage Waveforms (Comm HDKAL/HDKAS Only)

## generator set set Performance

**Regulation, No Load to Rated Load**

**Voltage:**  $\pm 2.5\%$

**Frequency:**  $\pm 2.5\%$

**Battery Charging:** 12 Volt Battery Charging DC Alternator (30 amp output)

**Sound Level:** 76 dB(a) @ 3 m rated load

**Random Frequency Variation** for Constant Loads

from No Load to Full Load is  $\pm 1\%$

**Random Voltage Variation:** for Constant Loads from No-Load to Full-Load is  $\pm 1\%$

**Maximum Operating Ambient Temperature:**

Efficient Radiator Cooling System Permits Operation at Ambient Temperatures up to 120°F (49°C).

## Accessories

**Required Accessory**

- (USDA Forest Service Approved Spark Arrester Muffler.

**Optional Accessories**

- Battery - 12 volt, 475 Cold Cranking Amps at 0°F (-17.8°C)
- Remote Gauge Package with Start/Stop/Preheat Switch, Voltage Meter, Water Temperature Gauge, Oil Pressure Gauge, Hour Meter (Standard on Comm HDKAL/HDKAS)

- Remote Circuit Breaker Kits
- Remote Wiring Harness, 10 or 30 ft.
- Engine Block Heater (Comm HDKAL/HDKAS Only)
- RACOR Fuel/Water/Separator (Comm HDKAL/HDKAS Only)
- Remote DC Gauge Kit (Comm HDKAL/HDKAS Only)

**THIS PAGE IS INTENDED TO BE BLANK**

# Introduction

## ABOUT THIS MANUAL

This manual is a guide for the installation of the Series HDKAL and HDKAS generator set sets (generator set sets). Proper installation is essential for top performance and safe operation. Read through this manual before starting the installation.

This manual addresses the following aspects of the installation:

- Location and Mounting
- Exhaust Connections
- Fuel Connections
- Electrical Connections (AC power output, remote control and battery)
- Startup

**⚠ WARNING ⚠ WARNING** *Improper installation can result in severe personal injury, death and equipment damage. The installer must be qualified to perform the installation of electrical and mechanical equipment.*

**⚠ CAUTION** *Unauthorized modifications or replacement of fuel, exhaust, air intake or speed control system components that affect engine emissions are prohibited by law in the State of California.*

See the Operator's Manual for operation and maintenance and the Service Manual for service.

**Note:** Manuals are updated from time to time to reflect changes in the equipment and its specifications. For this reason, only the copy of the installation manual supplied with the generator set set should be used as a guide for the installation.

## OUTLINE DRAWING AND FLOOR TEMPLATE

Page A-1 is a copy of the generator set set outline drawing which provides installation dimensions and the locations of all the connections that must be made.

Page A-2 is a reduced-scale copy of the generator set set floor template. Obtain a full-scale template

from your Cummins dealer to make it easier to locate the mounting holes and floor cutouts in the installation.

## INSTALLATION CODES AND STANDARDS FOR SAFETY

The builder of the RV or work vehicle bears sole responsibility for the selection of the appropriate generator set set, for its proper installation and for obtaining approvals from the authorities (if any) having jurisdiction over the installation. These sets meet the basic requirements of the Standard for Safety for Engine generator set Sets for Recreational Vehicles, ANSI/RVIA EGS-1. They are suitable for installation in accordance with:

- NFPA No. 70, Article 551—Recreational Vehicles and RV Parks
- NFPA No. 501C—Recreational Vehicles

Federal, State and local codes, such as the California Administrative Code—Title 25 (RV installation), might also be applicable. Installation codes and recommendations can change from time-to-time and are different in different countries, states and municipalities. It is recommended that the standards in Table be obtained for reference.

**TABLE . REFERENCE CODES AND STANDARDS**

NFPA Nos. 70 & 501C	National Fire Protection Association 470 Atlantic Avenue Boston, MA 02210
ANSI/RVIA-EGS-1	Recreational Vehicle Industry Association 14650 Lee Road Chantilly, VA 22021
California Administrative Code—Title 25, Chapter 3	State of California Documents Section P.O. Box 1015 North Highlands, CA 95660
CAN/CSA-Z240 Recreational Vehicles	Canadian Standards Association Housing and Construction Materials Section 178 Rexdale Blvd. Rexdale, Ontario, Canada M9W 1R3

## MANUFACTURING FACILITIES

Eje 120 No. 201, Zona Industrial, San Luis Potosí, C.P. 78395, San Luis Potosí, México.

Phone +52 444 870 6700

Fax +52 444 824 0082



**This page is intentionally blank.**

# Location, Enclosure and Mounting

---

Refer to the generator set set outline and floor template drawings on Pages A-1 and A-2. When locating and mounting the generator set set:

Orient the generator set set so that the control panel will be outboard and accessible. If that is not possible, remount the control box. See *Electrical Connections*.

Remote-mount the line circuit breakers if the location of the generator set set would not permit ready access. See *Electrical Connections*.

Provide access so that the service access door on the side or bottom of the generator set set can be fully opened.

Provide access for battery, fuel, remote control and AC connections.

Make sure that vehicle components located below the generator set set, including the generator set set muffler and tailpipe, will not interfere with draining engine oil or coolant.

Provide protection against direct road splash and rain.

Orient and enclose the generator set set so that cooling and ventilating air flow is not restricted. See *Ventilation and Cooling*.

If the generator set set is mounted within the cab or work space envelope of the vehicle, provide a vapor-tight, fire-resistive barrier between the

generator set set and the interior of the vehicle. Use approved materials (26 gauge galvanized steel or equivalent). See the NEC (NFPA 70) and California Title 25 for details.

**⚠WARNING** **EXHAUST GAS IS DEADLY.** **Construct a suitable vapor barrier of approved materials between the generator set set and vehicle interior to keep out exhaust gas.**

Use generator set set compartment acoustic insulation having at least a 250° F (121°C), "Self-Extinguishing" fire hazard classification.

Provide at least 1 inch (25.4 mm) clearance to the top of the generator set set compartment (including acoustic insulation). See Page A-2 (generator set set Floor Template) for minimum clearances around the sides.

Support the generator set set on a structure able to resist the dynamic weight of the generator set set:  $\pm 3$  g-force ( $\pm 1986$  lbf) vertical and  $\pm 1$  g-force ( $\pm 662$  lbf) horizontal. Use four 3/8-16 UNC bolts to secure the generator set set to the floor or frame.

**⚠WARNING** **Design the generator set set support structure carefully to prevent the generator set set from falling from the vehicle and possibly causing a serious road accident.**

**This page is intentionally blank.**

# Ventilation and Cooling

The generator set set has a liquid-cooled engine and a mounted radiator. Air flow through the radiator is provided by a crankshaft-mounted “pusher” or “suction” fan. The Option Code on the generator set set nameplate (Figure 1) designates the type of fan: Code **E093** for “pusher,” Code **E006** for “suction.”

## PUSHER FAN APPLICATIONS

In a “Pusher” application (Figure 2):

There must be at least 6 inches (152 mm) of clearance between either end of the generator set set and a bulkhead or other equipment if installed in a compartment with only the minimum openings. See COOLING SYSTEM TEST.

There must be an opening of at least 200 square inches of free open area in the generator set end of a compartment. The opening must line up with the generator set for straight air flow into the generator set.

If the space between the radiator and an enclosure wall is greater than 1/4 inch (6.4 mm), the space

must be closed off to prevent recirculation of air in the compartment. The duct or opening in the radiator end of a compartment must line up with the radiator core and be large enough that it does not block off any part of the radiator core area (15.50 inches wide by 12.14 inches high). A grille must have a free open area of not less than 55 percent.

Install the coolant recovery tank in accordance with the instructions in the kit.

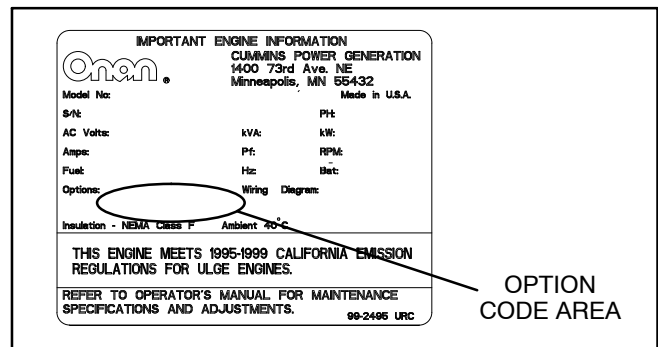


FIGURE 1. OPTION CODE AREA ON NAMEPLATE

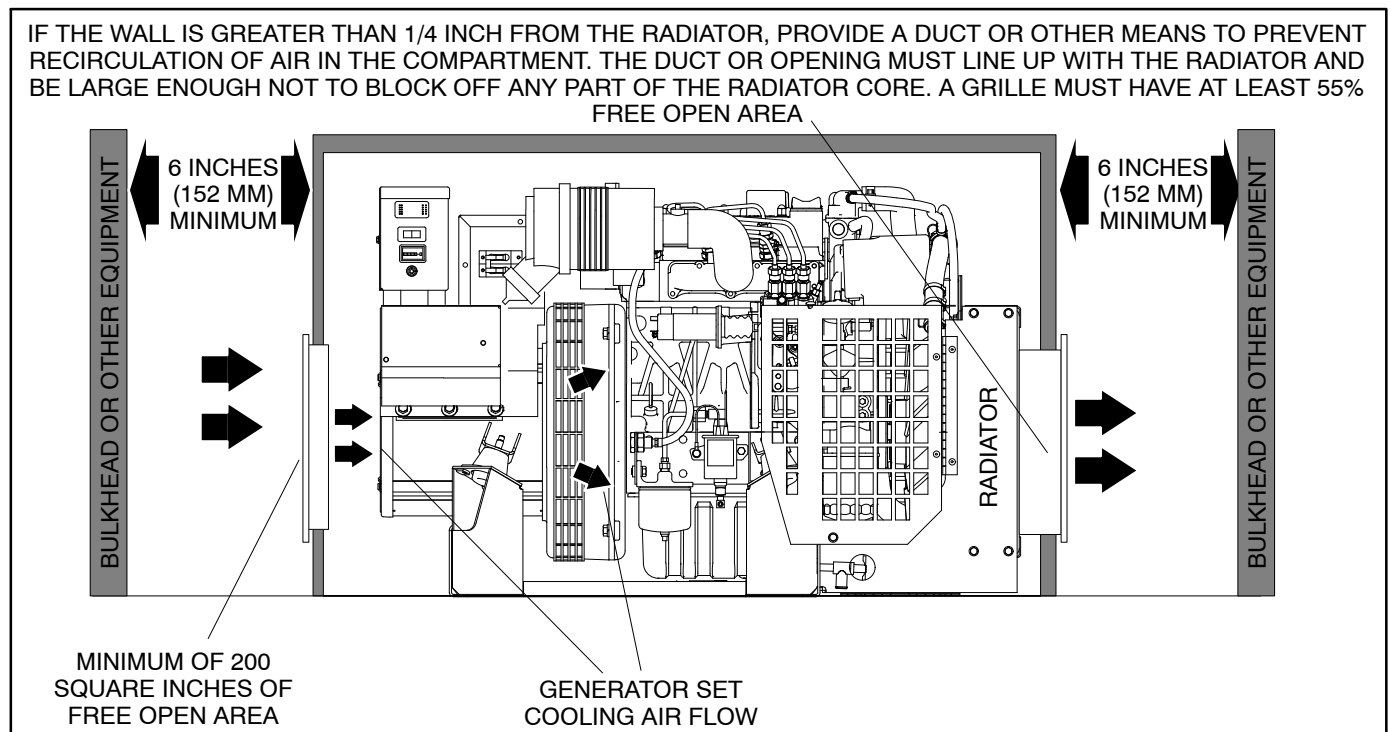


FIGURE 2. AIR FLOW THROUGH A COMPARTMENT IN A “PUSHER” FAN (CODE E093) APPLICATION

## SUCTION FAN APPLICATIONS

In a “Suction” application (Figure 3):

There must be at least 6 inches (152 mm) of clearance between either end of the generator set and a bulkhead or other equipment if installed in a compartment with only the minimum openings. See COOLING SYSTEM TEST.

There must be an opening of at least 200 square inches of free open area in the generator set end of a compartment.

If the space between the radiator and an enclosure wall is greater than 1/4 inch (6.4 mm), the space must be closed off to prevent recirculation of air in the compartment. The duct or opening in the

radiator end of a compartment must line up with the radiator core and be large enough that it does not block off any part of the radiator core area (15.50 inches wide by 12.14 inches high). A grille must have a free open area of not less than 55 percent.

Because compartment air in this configuration is heated by the radiator, generator set cooling and engine combustion air must be ducted from outside the compartment using the duct kit available from the factory for this kind of application. **Note that the duct adapter box on the generator set adds 2.28 inches (58 mm) to the length of the generator set set.**

Install the coolant recovery tank in accordance with the instructions in the kit.

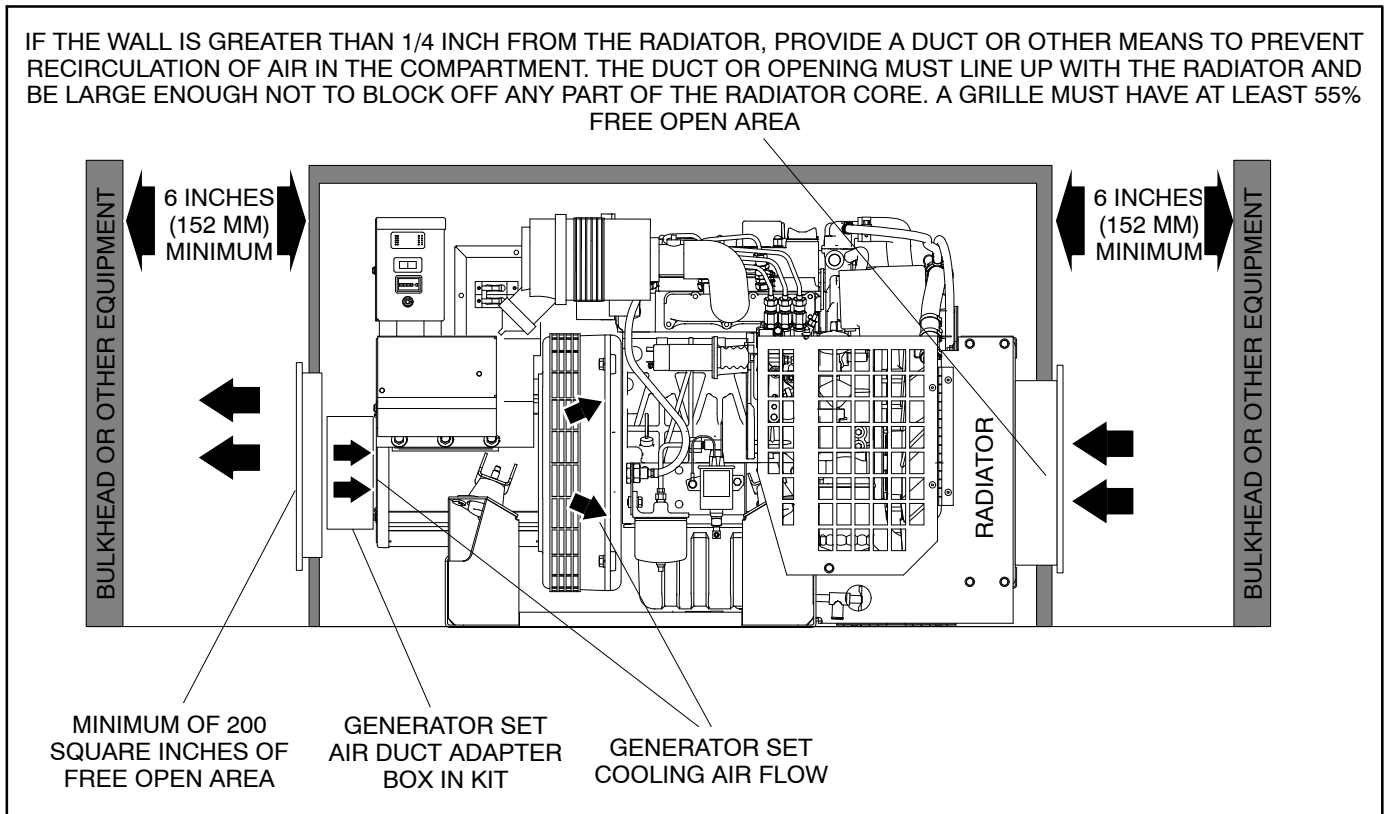


FIGURE 3. AIR FLOW THROUGH A COMPARTMENT IN A “SUCTION” FAN (CODE E006) APPLICATION

# COOLING SYSTEM TEST

## Purpose

The cooling system was designed to allow continuous full-load operation in ambients of 40°C (104°F) when the generator set set is fully enclosed in installations similar to Figures 2 and 3. Recirculation of air within the generator set set compartment, which can cause overheating, must be considered when installation constraints make it difficult to seal the radiator against a grill. A cooling test under full-load, measuring ambient air and engine coolant outlet temperatures, should be run to confirm the cooling capability of the generator set set in the proposed application. The goal is to achieve a Limiting Ambient Temperature of at least 40°C (104°F), where:

LAT = Limiting Ambient Temperature

$T_{(max)} = 107^{\circ} \text{C}$  (225° F). (The nominal engine shut-down temperature is 110° C [230°F]. Experience has shown that a margin of 3° C [5° F] is necessary to account for variations in senders, engine heat rejection, etc.)

$T_{(test)}$  = Measured engine coolant temperature (Table )

$T_{(amb)}$  = Measured ambient temperature (Table )

$$LAT = T_{(max)} - T_{(test)} + T_{(amb)}$$

If the goal for LAT of 40°C (104°F) is not met, cooling air recirculation must be reduced. In a pusher fan application, additional openings in a sides or the top of the compartment will significantly improve cooling performance.

In a suction fan application, a full cooling test will not be necessary if the measured air temperature into the radiator is not more than 14°C (25°F) above ambient temperature and the air inlet and outlet areas are equal to or greater than specified (Figure 3). Because compartment air in this configuration is heated by the radiator, generator set cooling and engine combustion air must be ducted from outside the compartment.

## Method

Complete a representative installation.

Use a load bank that can be adjusted to load the generator set set to its rated full-load.

Conduct the test at a location where the ambient air temperature will be equal to or greater than 21°C (70°F), to make sure that the engine coolant thermostat opens sufficiently.

Measure temperatures with thermocouples not heavier than No. 24 AWG (0.21 mm<sup>2</sup>).

1. Measure engine coolant outlet temperature at the outlet of the thermostat, making sure the bead of the thermocouple is centered in the coolant. The thermocouple wire can be routed between the hose and the thermostat outlet fitting without causing leaks.

A.. Measure ambient air temperature with a shielded thermocouple within 4 feet (1.2 meters) of the generator set set and at approximately the same height. Make sure the thermocouple will not be affected by warm air discharged from the generator set set or by sunlight. Use 2 inch diameter white PVC piping at least 6 inches long as a thermocouple shield.

For accurate test results, the coolant system must be free of air. Before starting the test:

B.. Add coolant as necessary.

C.. Expel air by adding and removing loads while the generator set set is running.

D.. Stop the generator set set to let the engine cool down so that the system can refill from the coolant recovery tank (which must be properly installed and filled).

Run the generator set set under full-load and record temperatures at 15 minute intervals until they stabilize. Readjust the load as necessary throughout the test to maintain full-load. Temperature is considered stable when there is no change in three consecutive temperature readings at 15 minute intervals. See Table for an example of how the data can be arranged for recording and analysis.

Calculate LAT using the test data in the formula. As an example:

$$LAT = 107^{\circ} \text{C}_{(max)} - 95^{\circ} \text{C}_{(test)} + 30^{\circ} \text{C}_{(amb)} = 42^{\circ} \text{C}$$

**TABLE . TEMPERATURE DATA**

THERMOCOUPLE LOCATION	TEMPERATURE C° (F°)				
	Time Of Reading				
AMBIENT AIR ( $T_{amb}$ )					
ENGINE COOLANT ( $T_{test}$ )					

**This page is intentionally blank**

# Exhaust Connections

**⚠WARNING** **⚠WARNING** **EXHAUST GAS IS DEADLY!** To keep exhaust gases from entering the vehicle do not terminate the exhaust tailpipe underneath the vehicle or closer than specified to openings into the vehicle (Figure 7) or route it such that it is likely to be damaged (Figure 8). Use approved materials and parts only.

The generator set set has a 1-1/4 inch NPT exhaust outlet that can be remounted to point up or down or towards the front or rear (Figure 4).

## MUFFLER

The RVIA/ANSI EGS-1 standard requires that mufflers be made of aluminized steel or other equivalent corrosion resistant material and that all seams be welded or crimped. A USDA approved spark arrester must be provided that is integral to the muffler or added on. Failure to provide and maintain a spark arrester can be a violation of U. S. Forest Service regulation 5100-1a (commercial vehicles as well as RVs).

Liability for damage or injury, and warranty expenses due to use of unapproved mufflers becomes the responsibility of the person installing the muffler. Contact a Cummins distributor or dealer for approved exhaust system parts.

Mount a spark arrester muffler with the cleanout plug pointing down so that soot can be expelled safely during cleaning.

Do not mount the muffler closer than 3 inches (76 mm) to combustible material (wood, felt, cotton, organic fibers, etc.) unless it is insulated or shielded. The temperature rise (above ambient) on adjacent combustible material must not exceed 117°F (65°C).

A muffler not mounted underneath the vehicle may need to be guarded against accidental contact.

**⚠WARNING** **⚠WARNING** **Mufflers are hot and can cause severe burns. Accidental contact must be prevented by muffler location or by guarding or shielding**

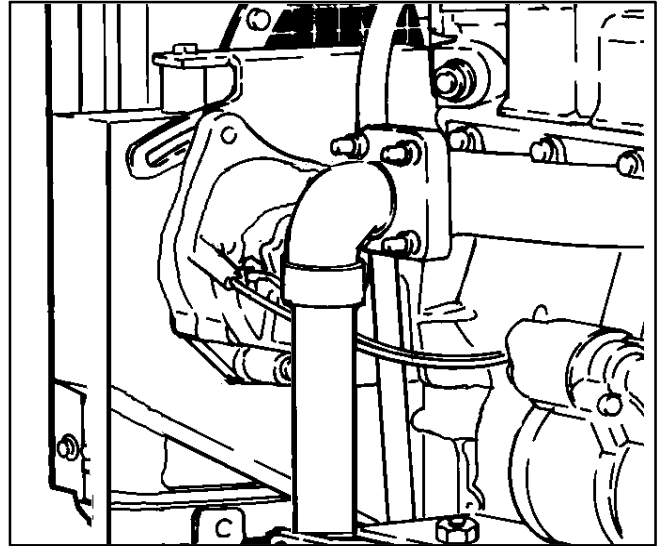


FIGURE 4. EXHAUST OUTLET



## TAILPIPE

When connecting and routing the tailpipe:

Use 18-gauge aluminized steel tubing or equivalent for the tailpipe. For exhaust system lengths up to 20 feet (6 meters) use 1-1/2 inch ID or larger tubing. Greater lengths may require larger tubing to prevent excessive exhaust back pressure. Do not use flexible exhaust tubing where the generator set set or exhaust tubing is under or adjacent to any area that could be occupied or where leaking exhaust could accumulate under or in areas that can be occupied.

Use U-bolt muffler clamps to connect sections of tailpipe. It is recommended that the overlapping pipe be slotted as shown in Figure 5.

Use automotive-type tailpipe hangers every 2 to 3 feet (0.6 to 0.9 m). Attach the hangers to steel framework, not to wood or other combustible material.

Do not terminate the tailpipe underneath the vehicle. Extend it a minimum of 1 inch (25 mm) beyond the perimeter of the vehicle (Figure 6). *Support the end of the tailpipe such that it cannot be pushed inward and up under the skirt of the vehicle.*

Do not route the tailpipe such that it will interfere with draining engine oil or coolant.

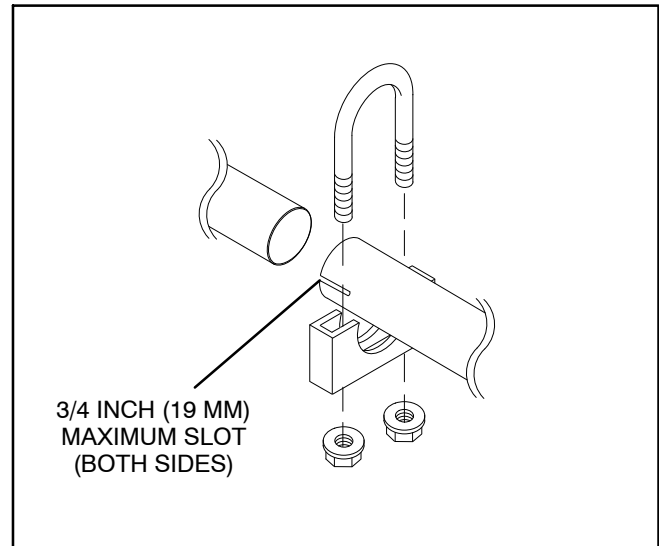
Do not route the tailpipe closer than 3 inches (76 mm) to combustible material (wood, felt, cotton, organic fibers, etc.) unless it is insulated or shielded. The temperature rise (above ambient) on adjacent combustible material must not exceed 117°F (65°C).

Unless the tailpipe is routed underneath the vehicle, it may be necessary to guard against accidental contact.

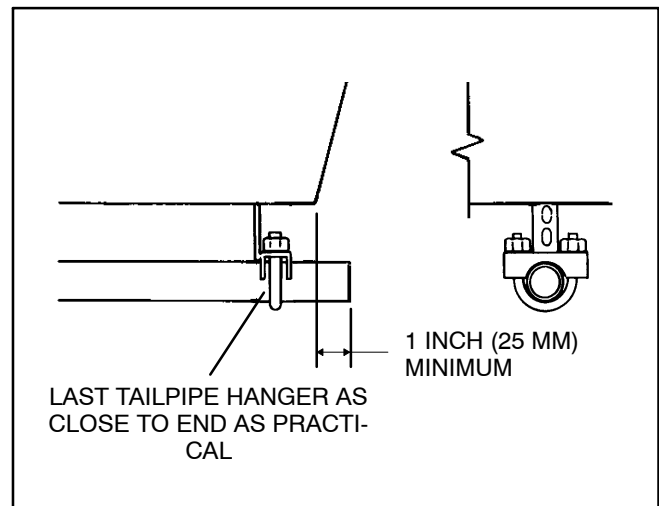
**⚠WARNING** *Tailpipes are hot and can cause severe burns. Accidental contact must be prevented by tailpipe location or by guarding or shielding.*

Do not route the tail pipe near fuel lines or fuel tanks.

Do not terminate the tailpipe such that it is closer than 6 inches (153 mm) to any opening into the vehicle interior (door, window, vent). See Figure 7.

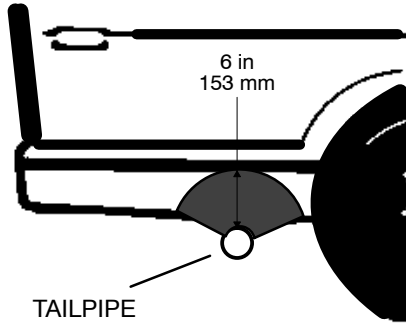


**FIGURE 5. EXHAUST TAILPIPE CONNECTIONS**



**FIGURE 6. TERMINATING THE EXHAUST TAILPIPE**

NO OPENING INTO THE VEHICLE INTERIOR MAY BE CLOSER THAN 6 INCHES (153 MM) TO THE END OF THE TAIL PIPE (WITHIN SHADED AREA)



**FIGURE 7. MINIMUM DISTANCES TO OPENINGS**

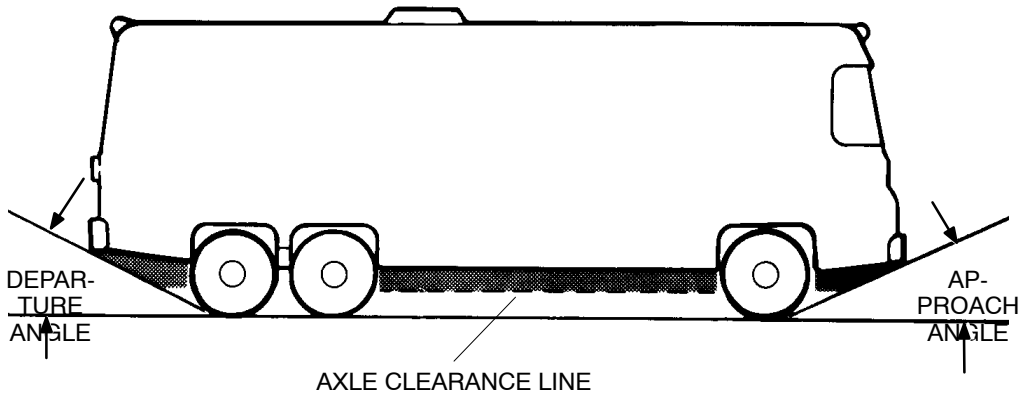
Do not connect the generator set set to the vehicle engine exhaust system.

**CAUTION** *Interconnecting the engine exhaust systems will allow exhaust condensates and soot to migrate into the engine that is idle, causing engine damage.*

Route the tailpipe such that it will not likely be struck when the vehicle is moving. At least keep it out of the approach and departure angles of the vehicle and above the axle clearance line (Figure 8).

*The exhaust back pressure under full load must not exceed 1.57 inches (40 mm) mercury column as measured within 6 inches (154 mm) of the exhaust manifold.*

**CAUTION** *Excessive back pressure can cause loss of performance and engine damage.*



**FIGURE 8. APPROACH AND DEPARTURE ANGLES AND AXLE CLEARANCE LINE**

**This page is intentionally blank.**

# Fuel Supply

See the Operator's Manual for recommended fuel. **Dirt and water in the fuel supply system can disable the engine.** Keep dirt and debris out when making fuel connections.

**⚠️ WARNING ⚠️ WARNING Diesel fuel is a combustible and can cause severe personal injury or death. Do not smoke or allow any flame, spark, pilot light, arc-producing equipment, electrical switch or other ignition source around fuel or fuel components, or in areas sharing ventilation. Keep a type ABC fire extinguisher handy.**

Do not interconnect generator set set and vehicle engine fuel lines. Follow the vehicle chassis manufacturer's instructions when making connections to the vehicle engine fuel tank. Unauthorized fuel system modifications can cause dangerous operating conditions.

**⚠️ CAUTION** *Either or both engines could starve for fuel if the generator set set and vehicle engine fuel lines are interconnected. Always use separate fuel lines or a separate fuel tank for the generator set set.*

To prevent the generator set set from running the vehicle out of fuel, terminate the fuel pickup tube for the generator set set higher up in the tank than the one for the vehicle engine.

Use approved flexible fuel hose for supply and return connections at the engine (Figure 9) to take up generator set set movement and vibration.

Cummins recommends seamless steel tubing with flared fittings for long runs of fuel line. Run fuel lines at or above the top of the fuel tank to reduce the risk of siphoning fuel out of the tank if the line should break.

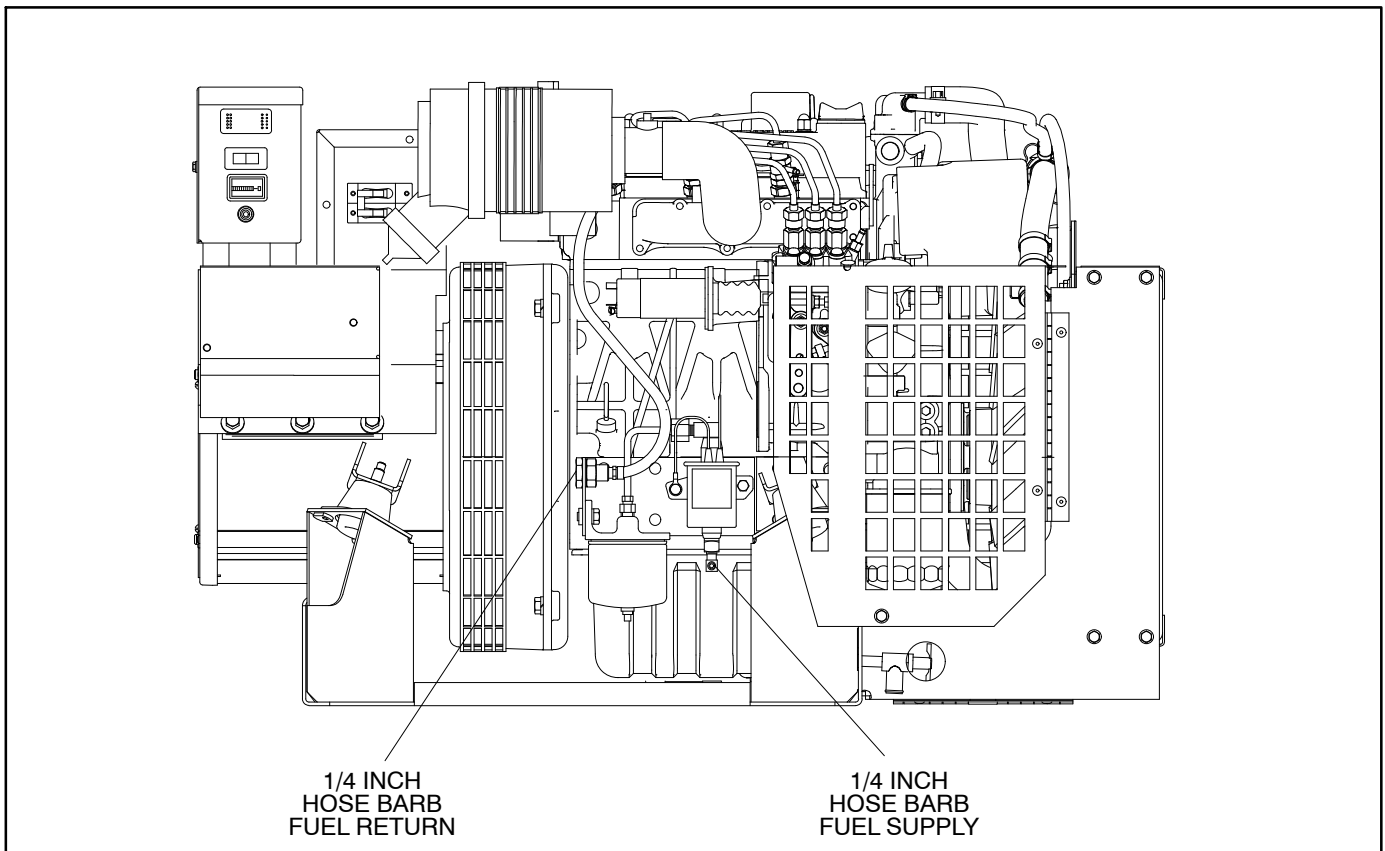


FIGURE 9. FUEL CONNECTIONS

Route fuel lines away from electrical wiring and hot engine exhaust components. Fuel lines should be accessible for inspection and replacement, protected from damage and secured to prevent kinking, contact with sharp edges and chafing due to vibration.

**⚠ CAUTION** *Do not use galvanized fuel tanks, fittings and pipes. Sulfur in diesel fuel attacks the galvanized (zinc) coat causing debris that can clog fuel filters, pumps and injectors.*

The fuel lift pump mounted on the generator set set can handle fuel suction heads of up to 3 feet (0.9 m) due to lift height and pipe friction. When the generator set set is mounted such that the fuel inlet is more than 3 feet above the bottom of the fuel dip tube in the fuel tank, an auxiliary fuel lift pump and automatic fuel shutoff device must be installed ahead of the generator set set lift pump (Figure 10). A shutoff device is necessary to keep the fuel in the line from draining back to the tank and causing hard starting.

The auxiliary pump and solenoid should be electrically connected in parallel with the generator set set fuel pump to the engine harness lead from connector pin J2-2, as shown in the schematic. It is recommended that an insulated piggy back Faston connector be used for the connections at the generator set set pump lead.

The fuel shutoff solenoid prevents fuel from draining back to the tank and causing the pumps to lose prime.

**⚠ CAUTION** *Do not install a mechanical check valve in the fuel supply line. Fuel trapped between the check valve and the check valve internal to the generator set set fuel pump can damage the check valve when the fuel expands due to a rise in temperature.*

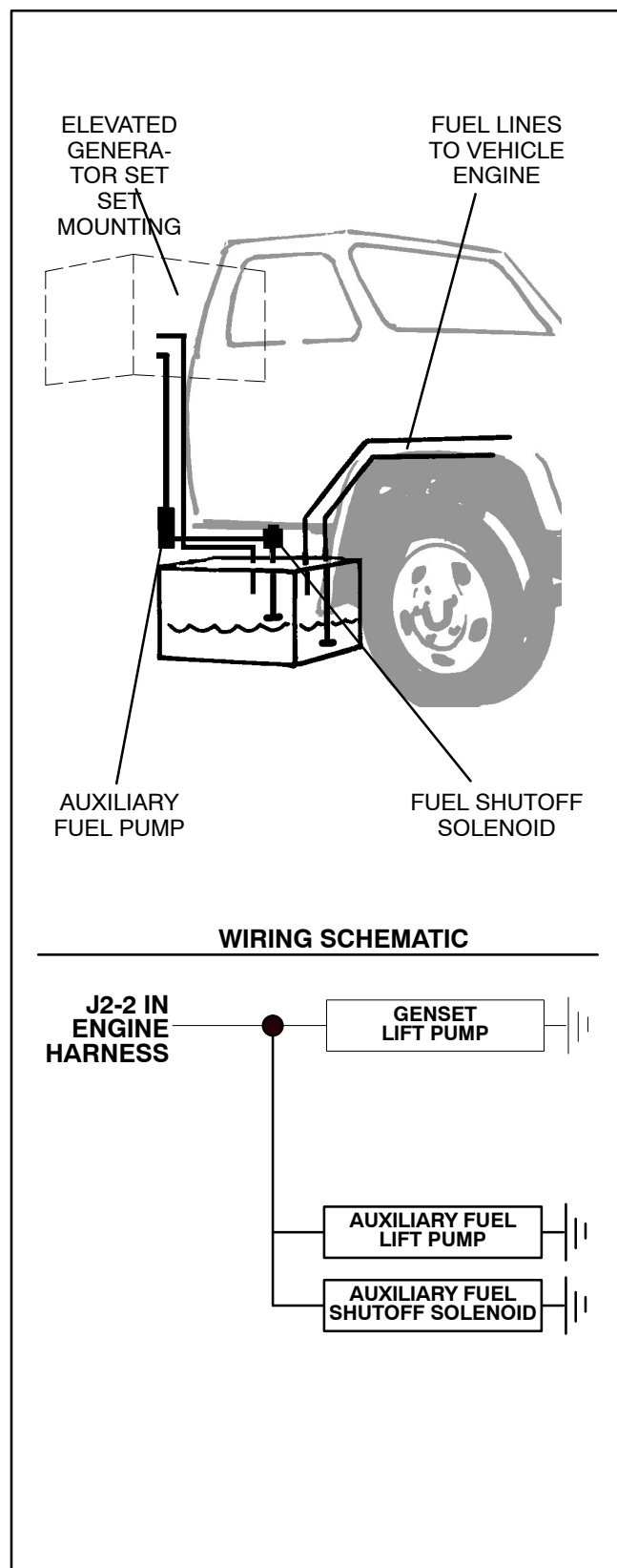


FIGURE 10. AUXILIARY FUEL LIFT PUMP

## BIO-DIESEL FUELS B5 – B20

### Approved Bio-Diesel Fuel:

- For bio-diesel blends above B5 and up to B20, Cummins requires that the fuel meet the specifications outlined in ASTM D7467.
- The bio-diesel component of this fuel blend must meet ASTM D6751 or EN14214 and the petroleum-diesel component must meet ASTM D975.

For bio-diesel blends above B5 and up to B20 the following installation requirements must be met:

- Natural rubber, butyl rubber, and some types of nitrile rubber may be particularly susceptible to degradation when exposed to bio-diesel. Copper, bronze, brass, tin, lead, and zinc can cause deposit formations. The use of these materials and coatings should be avoided for vehicle fuel tanks and fuel lines. Always check with component manufacturers to confirm compatibility with B20.
- Fuel tanks must be made from the following materials: aluminum, steel, fluorinated polyethylene, fluorinated polypropylene or Teflon (PTFE).
- Verify the vehicle propulsion engine is capable of using B20 when sharing the same fuel tank with the generator set set.
- A bio-diesel compatible fuel water separator is required. Because water separators do not work as well with bio-diesel as they do with petroleum-based diesel, it is very important to prevent water from entering the fuel supply.

Place the fuel water separator in a location that is accessible for service by as close the genera-

tor set set as possible. Locating the separator ahead of the generator set set fuel pump is acceptable.

### Additional information:

- Bio-diesel blends have higher pour and cloud points than standard diesel fuels. generator set set locations far from the fuel tank combined with low fuel flow rates can make the generator set set fuel system very susceptible to fuel starvation related to gelling in cold weather (below 23°F/ -5°C). In addition to electric or coolant tank heaters, consideration to routing and possible heating or insulation of the fuel lines to the generator set set may be needed.
- Bio-Diesel blends can oxidize more quickly than standard diesel fuels; more frequent fuel filter service intervals are required and shorter fuel storage life in tanks is likely.

**⚠WARNING** It is highly recommended that specific market applications are avoided or exercised with extra care due to some of the properties of bio-diesel fuel blends such as cold weather operation, long term storage, material incompatibilities and other effects on engine operating characteristics. Such applications that should use standard fuels include applications that will experience seasonal usage, storage for periods exceeding 90 days, and extreme temperatures or humidity.

### Storage requirements:

- If using bio-diesel for seasonal applications (stored more than 90 days), the generator set set must be purged before storage by running the engine on pure diesel fuel meeting ASTM D975 for a minimum of 30 minutes.

**TABLE 1. CUMMINS BIO-DIESEL RECOMMENDATIONS**

<b>APPLICATION</b>	<b>RECOMMENDATION FOR BIO-DIESEL BLENDS</b>	<b>RECOMMENDATIONS</b>	<b>COMMENTS</b>
Emergency Standby RV Seasonal/Commercial with low annual hour accumulation	Not Recommended	Use petroleum diesel only.	Low fuel usage and critical start nature of Emergency Standby make bio-diesel impractical.
Limited Time Prime	Approved with Recommendations	Use fuel within 6 months of manufacture. Flush fuel system with petroleum diesel prior to storage.	Bio-diesel is suitable for constant high load operation with proper precautions.
Unlimited Time Prime	Approved with Recommendations	Use fuel within 6 months of manufacture. Flush fuel system with petroleum diesel prior to storage/transport.	Bio-diesel is suitable for variable load operation with proper precautions.
Continuous	Approved with Recommendations	Use fuel within 6 months of manufacture.	Bio-diesel is suitable for base load operation with proper precautions.

# Electrical Connections

---

## GENERATOR SET CONNECTIONS

Prevent accidental starting of the generator set set during installation by not connecting the battery cables at the battery until so instructed in *Installation Checks and Startup*.

**⚠️WARNING ⚠️WARNING** *Accidental starting of the generator set set can cause severe personal injury or death. Do not connect the starting battery until so instructed in Installation Checks and Startup.*

### Line Circuit Breakers

Line circuit breakers are available in a range of ampere ratings for mounting in the AC output box. Circuit breaker mounting boxes are available as kits for remote mounting if the breaker reset handles would not be accessible as installed on the generator set set.

### generator set Reconnections

These generator sets are reconnectable in accordance with the reconnection diagram inside the output box cover. Line circuit breakers, if required, must have the appropriate ampere rating for the generator set set, as reconnected. Also, voltage may have to be readjusted. See *Voltage Adjustments*.

### Transfer Switch

Use an approved transfer switch if provision is made for connecting the vehicle to utility power.

**⚠️WARNING ⚠️WARNING** *Backfeed to utility power can cause electrocution and damage to equipment. Use an approved device to prevent the generator set set from being interconnected with utility power.*

### Wiring Methods

Wiring methods must be in accordance with applicable codes, such as the National Electrical Code (NFPA No. 70).

Use flexible conduit and stranded conductors to make connections at the generator set set output box to take up generator set set movement and

vibration. Make connections directly to the generator set leads or to the circuit breaker terminals, if so equipped.

Use rain-tight conduit, conduit connectors and junction boxes for all exterior wiring.

Route or protect AC wiring so that it will not be cut or abraded, exposed to hot surfaces or damaged by road debris. Keep AC wiring away from fuel lines and control wiring.

**⚠️WARNING ⚠️WARNING** *Routing AC wiring with fuel lines can lead to fire and severe personal injury or death. Keep AC wiring away from fuel lines.*

Seal all wiring entrance holes into the interior of the vehicle (inside and outside all conduit connectors) to keep out exhaust gas. Use silicone rubber or an equivalent type of sealant.

**⚠️WARNING ⚠️WARNING** *EXHAUST GAS IS DEADLY! Seal all wiring openings into the vehicle interior to keep out exhaust gas.*

Use ground-fault circuit interrupters (GFCIs) for branch circuits with power receptacles.

Use vibration-proof switches and controls to prevent the opening and closing of circuits while the vehicle is moving.

### Grounding

The generator set set, power supply wiring and all connected electrical equipment must be bonded for grounding in accordance with applicable regulations.

**⚠️WARNING** *Faulty bonding for grounding can lead to fire and electrocution, resulting in severe personal injury or death. Grounding must comply with applicable regulations.*

### Load Balancing

Check load balance between L1 and L2 on single-phase generator set sets and between L1, L2 and L3 on three-phase generator set sets. Redistribute the loads as necessary so that current does not exceed nameplate rating for any phase. Loads should be balanced within 10 percent.



## REMOTE CONTROL CONNECTIONS

Provision is made for remote starting and stopping of the generator set set. A ten-pin remote connector (J3) mounted on the control box connects the harness assembly to connector J4 on the remote control assembly. Several remote control kits complete with installation instructions are available. Also available are complete harness assemblies with connectors. Call a Cummins dealer or distributor for assistance in securing these items. Alternatively, refer to the wiring diagram in Figure 11 to fabricate a

harness. Use 18 AWG wire. The electrical code does not allow control wiring to be routed through the same conduit as AC wiring.

Be sure to seal all openings made for wiring so exhaust or fuel vapors cannot enter the living quarters or work area. Conduit must be sealed internally at the end where it terminates within the junction box or panel board.

**⚠ WARNING ⚠ WARNING EXHAUST GAS IS DEADLY! Seal all wiring openings into the vehicle interior to keep out exhaust gas.**

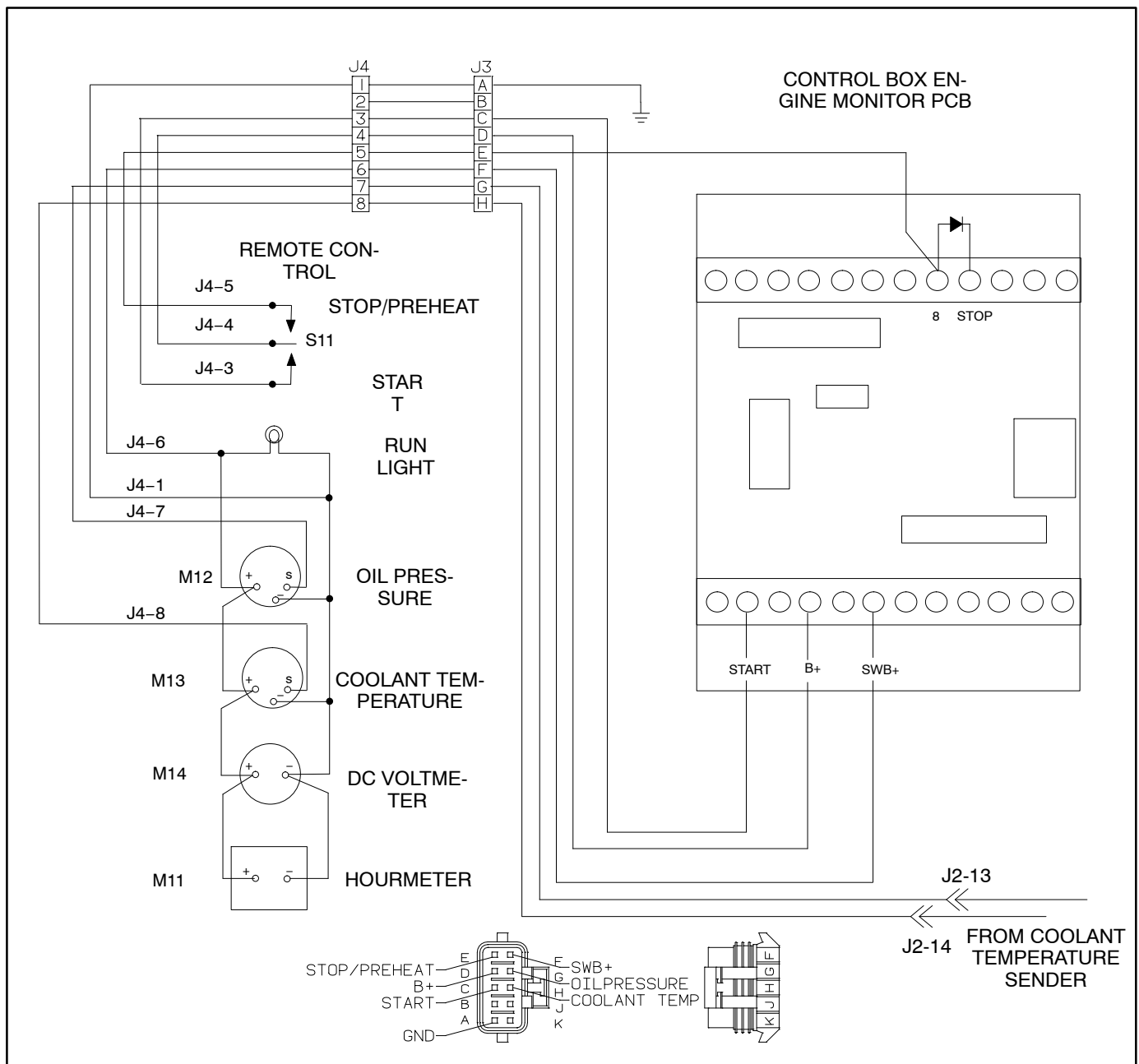


FIGURE 11. TYPICAL REMOTE CONTROL WIRING

## REMOTE MOUNTING CONTROL BOX

If the generator set control panel (Figure 12) would not be accessible as installed, the control box may be remotely mounted at an accessible location. Harnesses of various lengths are available for re-connecting the control box to the generator set.

The new location should not subject the control box to more vibration than on the generator set, to contamination by oil or dirt or to ambient temperatures greater than 160°F (71°C).

Remove the DC control box cover and unscrew the bolts from the four vibration isolators (rubber mounting feet) that support the control box. Remove the control box and isolators from the studs on the mounting surface. Drill holes of the appropriate size and place the box in the new position. Make sure that there is enough room to insert and remove the wiring harness connector plugs in the back of the control box (Figure 13).

If the new location is relatively free of vibration, it may not be necessary to remount the box on its vibration isolators. If the box is to be remounted on its isolators (Figure 13), **the toothed washers must be mounted under the vibration isolators as shown to prevent the isolators from rotating.** This type of isolator deteriorates rapidly if not prevented from rotating under the weight of the control box.

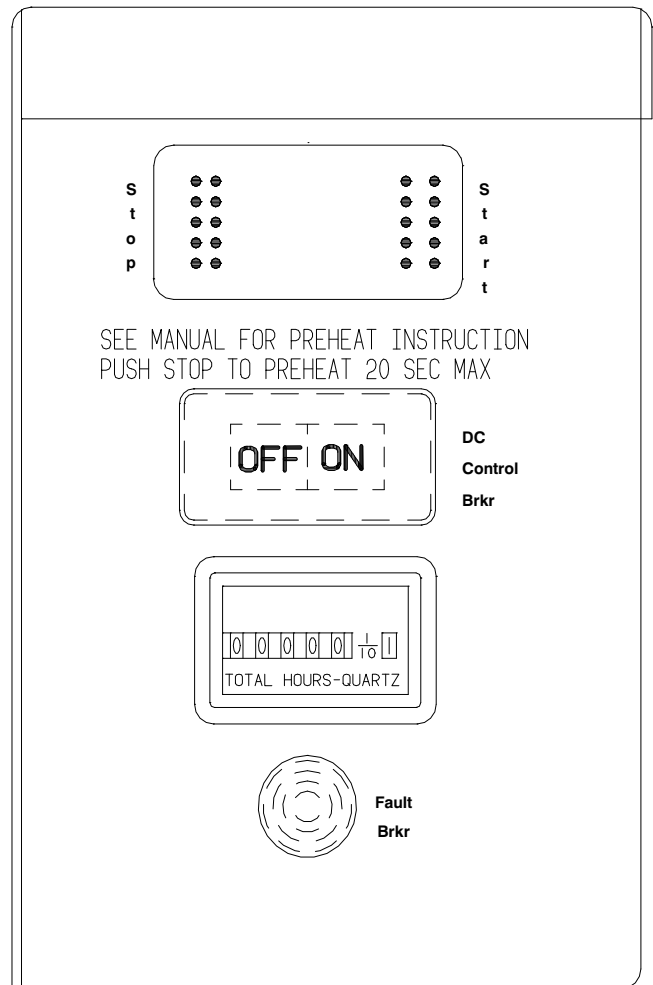


FIGURE 12. generator set set CONTROL PANEL

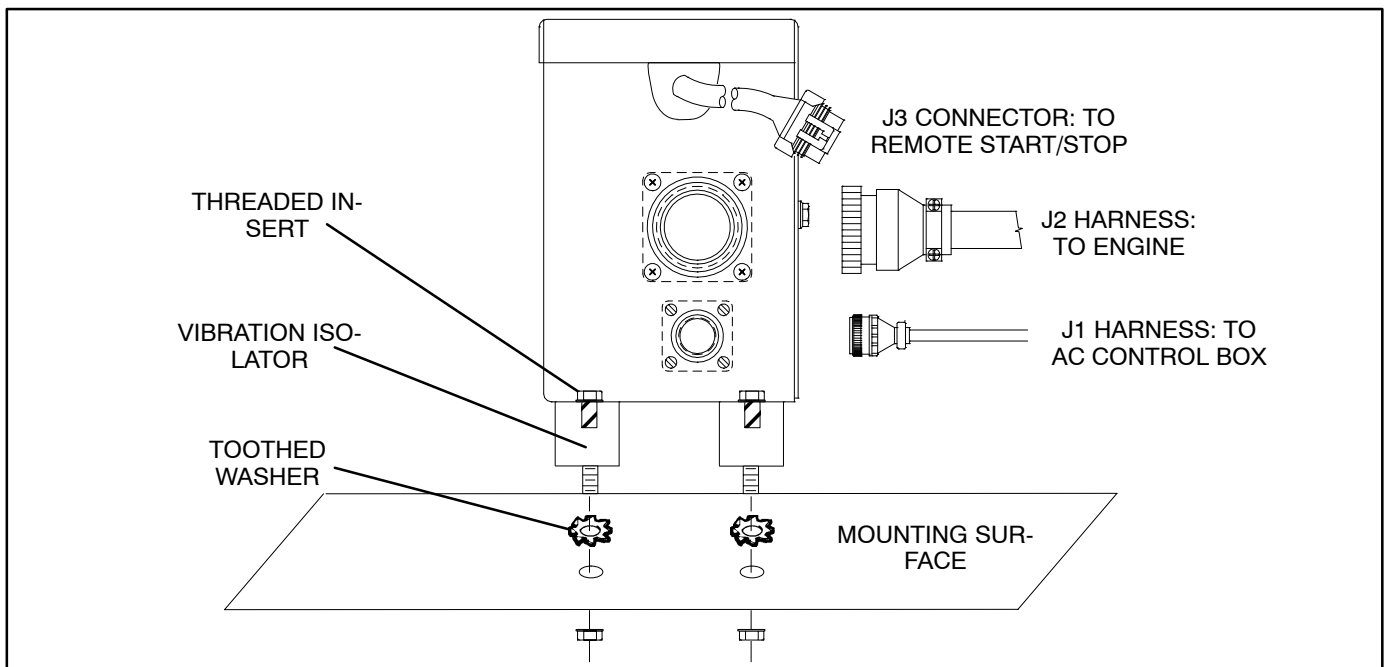


FIGURE 13. REMOTE MOUNTING OF THE GENERATOR SET SET CONTROL BOX

## BATTERY CONNECTIONS

Prevent accidental starting of the generator set set during installation by not connecting the battery cables at the battery until so instructed in *Installation Checks and Startup*.

**⚠️WARNING ⚠️WARNING** *Accidental starting of the generator set set can cause severe personal injury or death. Do not connect the starting battery until so instructed in Installation Checks and Startup.*

### Battery Capacity

The generator set set has a 12 VDC, negative-ground control and starting system. See Table for minimum battery capacity requirements.

**TABLE . MINIMUM BATTERY CAPACITY**

<i>Down to 0 F (-17 C)</i>	<i>475 CCA*</i>
<i>Down to -20 F (-29 C)</i>	<i>650 CCA*</i>
<i>* Cold Cranking Amps</i>	

### Battery Recharging

The generator set set is equipped with an engine-driven battery charging alternator.

### Battery Compartment

Batteries must be mounted in a separate compartment from that of the generator set set, away from spark-producing equipment. The positive (+) terminal must be shielded from accidental contact. An enclosed compartment must have openings of at least 1.7 square inches (11 square centimeters) at

the top and bottom for ventilation of battery gasses. Batteries should be mounted such that spills and leaks will not drip acid on fuel lines, wiring and other equipment that could be damaged.

**⚠️WARNING ⚠️WARNING** *Arcing can ignite the explosive hydrogen gas given off by the battery, causing severe personal injury. The battery compartment must be ventilated and must isolate the battery from spark-producing equipment.*

### Battery Cables

Size battery cables according to Table . Alternatively, use rated cranking current as the basis for calculating battery cable size. Rated cranking current for these generator set sets is 280 amperes at 0° F (-18°C). The cables should be sized so that voltage across the cranking motor terminals will be within 1 volt of the voltage across the battery terminals.

**TABLE . BATTERY CABLE SIZES FOR AMBIENT TEMPERATURES DOWN TO -20°F (-29°C)**

<b>CABLE LENGTH (DISTANCE OF BATTERY FROM generator set set), FEET (METERS)</b>	<b>CABLE SIZE, AWG</b>
<i>0 to 10 (0 to 3)</i>	<i>2*</i>
<i>11 to 15 (3 to 4.5)</i>	<i>0</i>
<i>16 to 20 (4.5 to 6.1)</i>	<i>000</i>
<i>* - Acceptable for up to 20 feet (6.1 meters) in warmer climates (above 32 °F [0 °C]) or when battery capacity totals at least 1000 CCA (Cold Cranking Amps).</i>	

The current path between the generator set and the negative (-) battery terminal must also be able to carry full cranking current without causing excessive voltage drop. It is highly recommended, therefore, that a full-length cable, sized the same as the positive (+) cable, be used to connect the generator set to the negative (-) battery terminal (Figure 14).

When full-length cables are run from both terminals of the battery to the generator set (Figure 14), bonding conductors from the generator set and battery to the vehicle frame may be required by code.

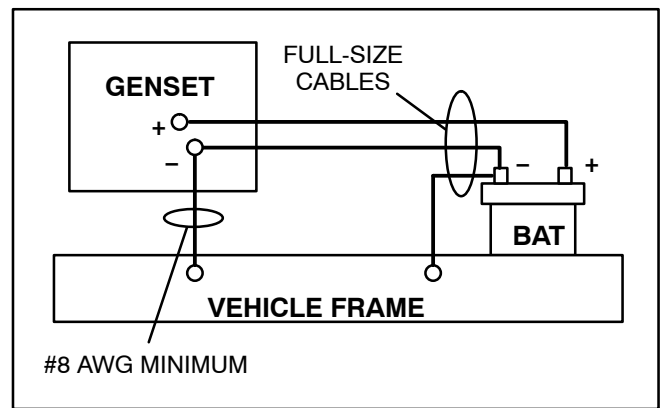
A vehicle frame member used as a path from the negative (-) battery terminal (Figure 15) must have a substantial cross-section. The electrical resistance of riveted or bolted frame joints in the path of battery cranking currents must also be carefully considered, especially if the joints will be exposed to corrosive road conditions.

When a frame member is used as a path for battery current, a cable must be used to connect the frame to the designated negative (-) terminal on the generator set (Figure 16). The cable must be of the same gauge as the cable from the positive (+) terminal of the battery. ***The generator set mounting bolts are not considered adequate means for bonding the generator set to the vehicle frame, either for the purpose of carrying cranking currents or for complying with requirements for generator set/system grounding.***

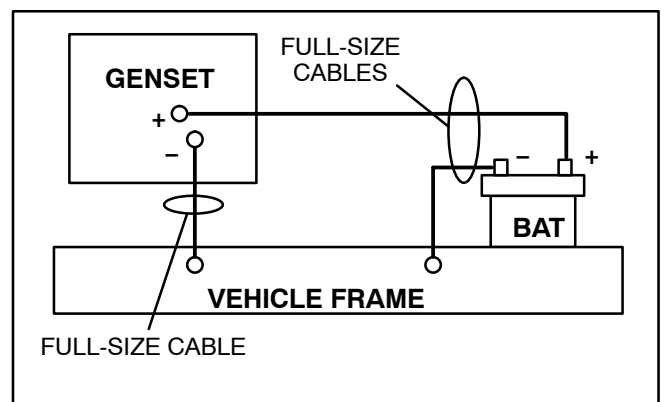
Route battery cables away from fuel lines and hot engine exhaust components. Battery cables should be accessible for inspection and replacement, protected from damage and secured to prevent chafing due to vibration.

**⚠️WARNING ⚠️WARNING** ***Routing battery cables with fuel lines can lead to fire and severe personal injury or death. Keep battery cables away from fuel lines.***

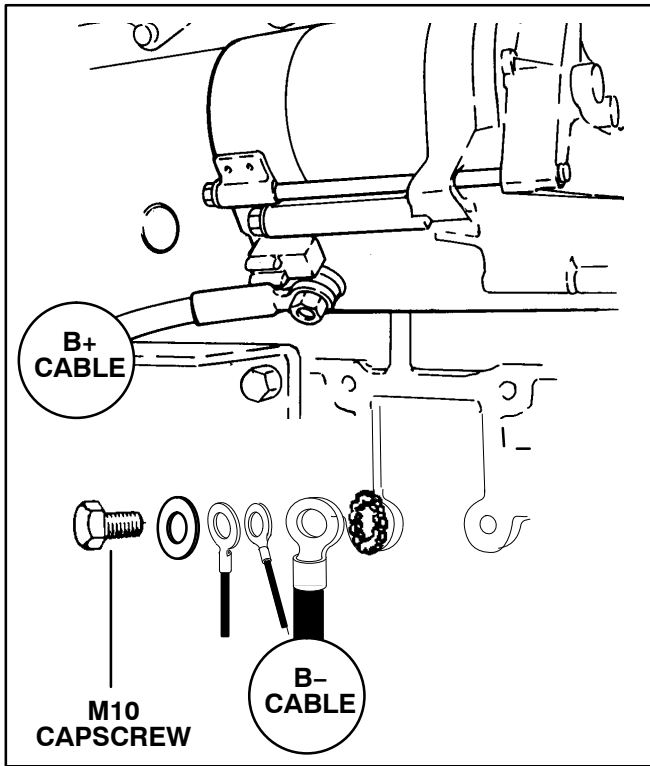
Terminate the battery cables with appropriately sized eyelet connectors and connect them to the generator set as shown in Figure 16. For a good electrical connection, use an external/internal-toothed washer, as shown, between the engine block and the negative (-) battery cable connector.



**FIGURE 14. FULL-LENGTH CABLE AS PATH FROM BATTERY NEGATIVE (-) TERMINAL**



**FIGURE 15. VEHICLE FRAME AS PATH FROM BATTERY NEGATIVE (-) TERMINAL**



**FIGURE 16. THE GENERATOR SET SET TERMINALS FOR THE BATTERY CABLES**

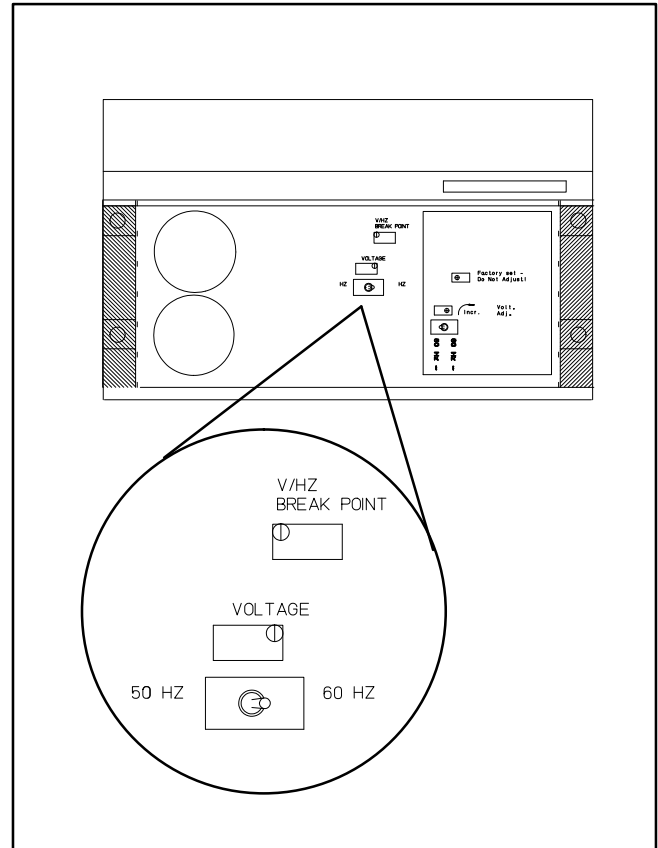
# Voltage Adjustments

**⚠WARNING** **⚠WARNING** **HAZARDOUS VOLTAGE!** Touching uninsulated live parts inside the output box can result in severe personal injury or death. For your protection, stand on a dry wooden platform or rubber insulating mat, make sure your clothing and shoes are dry, remove jewelry from your hands and use tools with insulated handles.

This generator set is designed for either 50 Hz or 60 Hz and is not convertible. The generator set, however, can be reconnected and the voltage regulator readjusted for a range of outputs at the design frequency.

Check output voltage if generator set reconnections have been made and readjust as necessary. The voltage regulator is mounted on the side of the generator set below the control box. Remove the protective cover for access to the voltage adjusting pot and 50/60 Hz selector switch (Figure 17). **The other adjusting pot (V/HZ break point) is factory sealed and must not be adjusted.**

Check the position of the 50/60 Hz selector switch and change it if necessary. Then adjust **no-load voltage** as required and replace the cover.



**FIGURE 17. VOLTAGE ADJUSTMENTS**

**This page is intentionally blank.**

# Installation Checks and Startup

---

**Before starting the generator set set**, review the installation checklist below for those items that do not require the generator set set to be actually running. Make necessary repairs, reconnections and modifications.

When all installation requirements have been met, connect the battery cables to the battery, positive (+) cable first. Then start and operate the generator set set in accordance with the Operator's Manual, observing all of its instructions and precautions. Continue working through the installation checklist with the generator set set running, making necessary repairs, reconnections and modifications. Check off (√) each item that can be answered positively. Do not place the generator set set in service until every applicable item has been checked off.

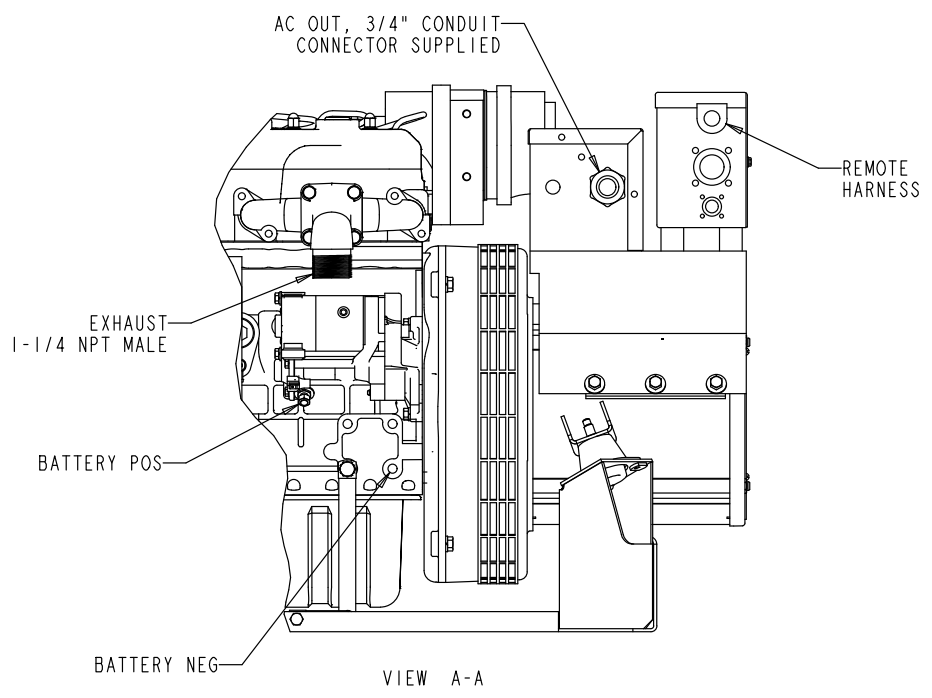
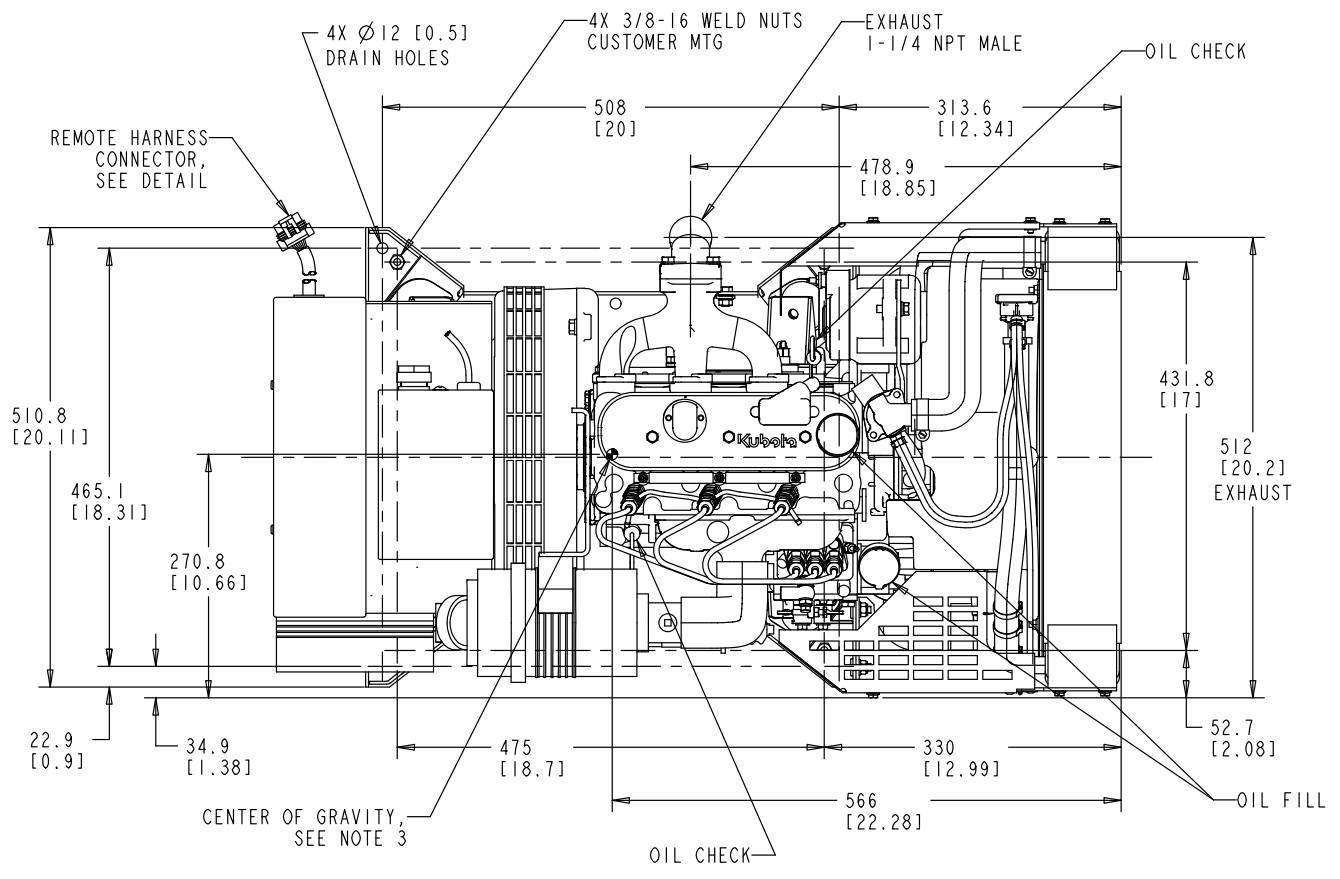
**⚠WARNING ⚠WARNING Arcing at battery terminals, arcing in light switch or other equipment, flame, and sparks can ignite battery gas causing severe personal injury.**

**⚠WARNING Ventilate battery area before working on or near battery—Wear safety glasses—Do not smoke—Switch trouble light ON or OFF away from battery—Stop generator set set and disconnect charger before disconnecting battery cables—Disconnect negative (-) cable first and reconnect last.**

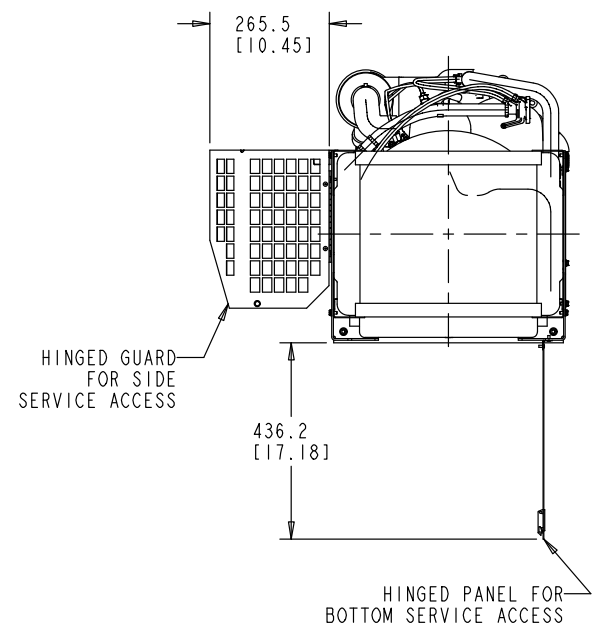
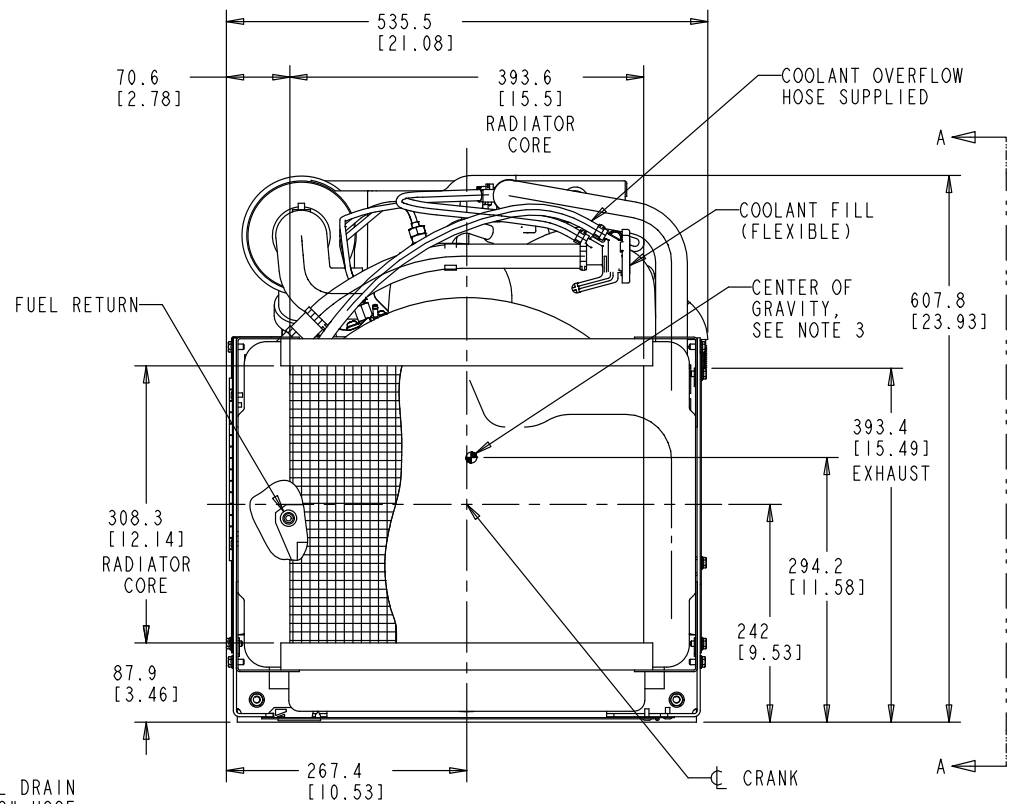
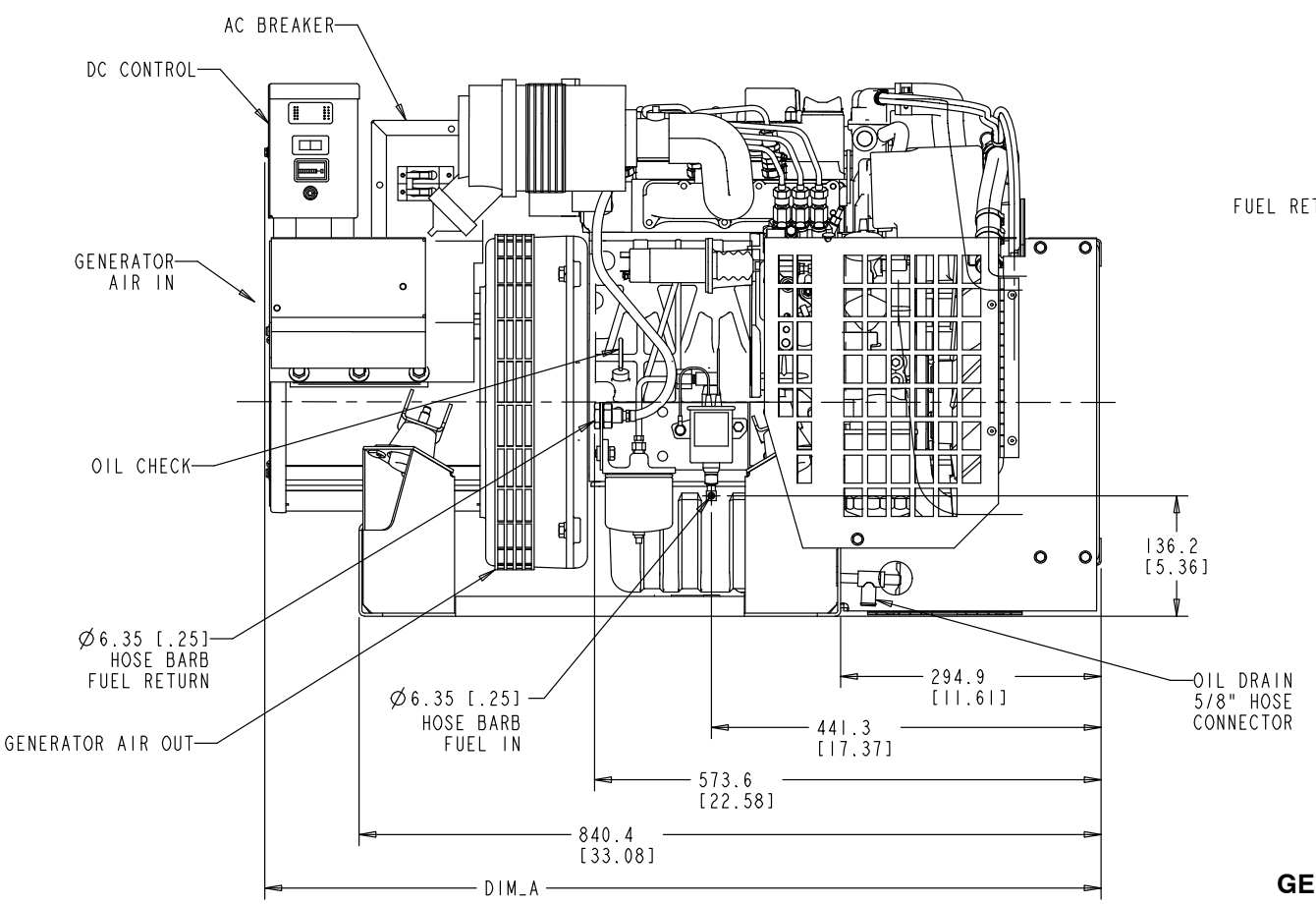
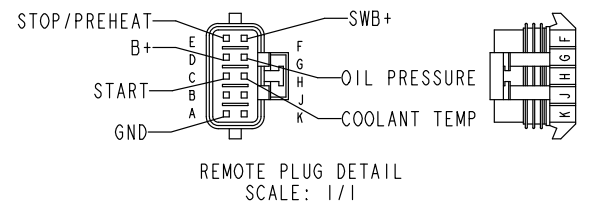
- The generator set set is securely and adequately mounted and protected from direct road splash.
- The generator set set is located outside the interior (cab, living space) of the vehicle and separated by approved vapor-tight and fire-resistant materials.
- The control panel and circuit breaker reset handles are visible and easily accessible.
- The remote control panel functions as intended.
- There is adequate clearance for performing all maintenance specified in the Operator's Manual.
- The coolant recovery tank is mounted properly and is accessible for inspection and filling.
- The engine coolant system is leak-free.
- The engine has the proper levels of oil and coolant.
- The entire exhaust system is accessible for inspection and replacement.
- The tailpipe terminates at least 1 inch (25 mm) beyond the perimeter of the vehicle and at least 6 inches (153 mm) away from any opening into the vehicle.
- Approved methods and materials are used to protect combustible construction and operators from hot mufflers and piping.
- The exhaust system is leak-free and conveys all engine exhaust outside, away from windows, doors and vents.
- Exhaust back pressure is acceptable.
- Enclosure openings and cooling and ventilating air flow is such that the generator set set can maintain full-rated load without overheating.
- Approved flexible fuel lines are used for connections at the engine.
- Fuel tanks and piping comply with regulations.
- The fuel supply system is leak-free.
- A properly sized battery has been installed, serviced and charged. The battery is securely mounted in an adequately ventilated space and the positive (+) terminal is shielded from accidental contact.
- AC wiring methods, materials and bonding for grounding meet regulations.
- All wiring holes into the vehicle interior (inside and outside conduit connectors) are sealed to keep out exhaust gas.
- Voltage and frequency are correct for the application, the generator set set is properly sized and the loads are balanced.
- An approved transfer switch prevents interconnections with utility power.
- All operators have been thoroughly briefed on the Operator's Manual and its safety precautions—especially concerning the danger of carbon monoxide gas—and can demonstrate how to operate, maintain and troubleshoot the generator set set as explained therein.



**This page is intentionally blank.**



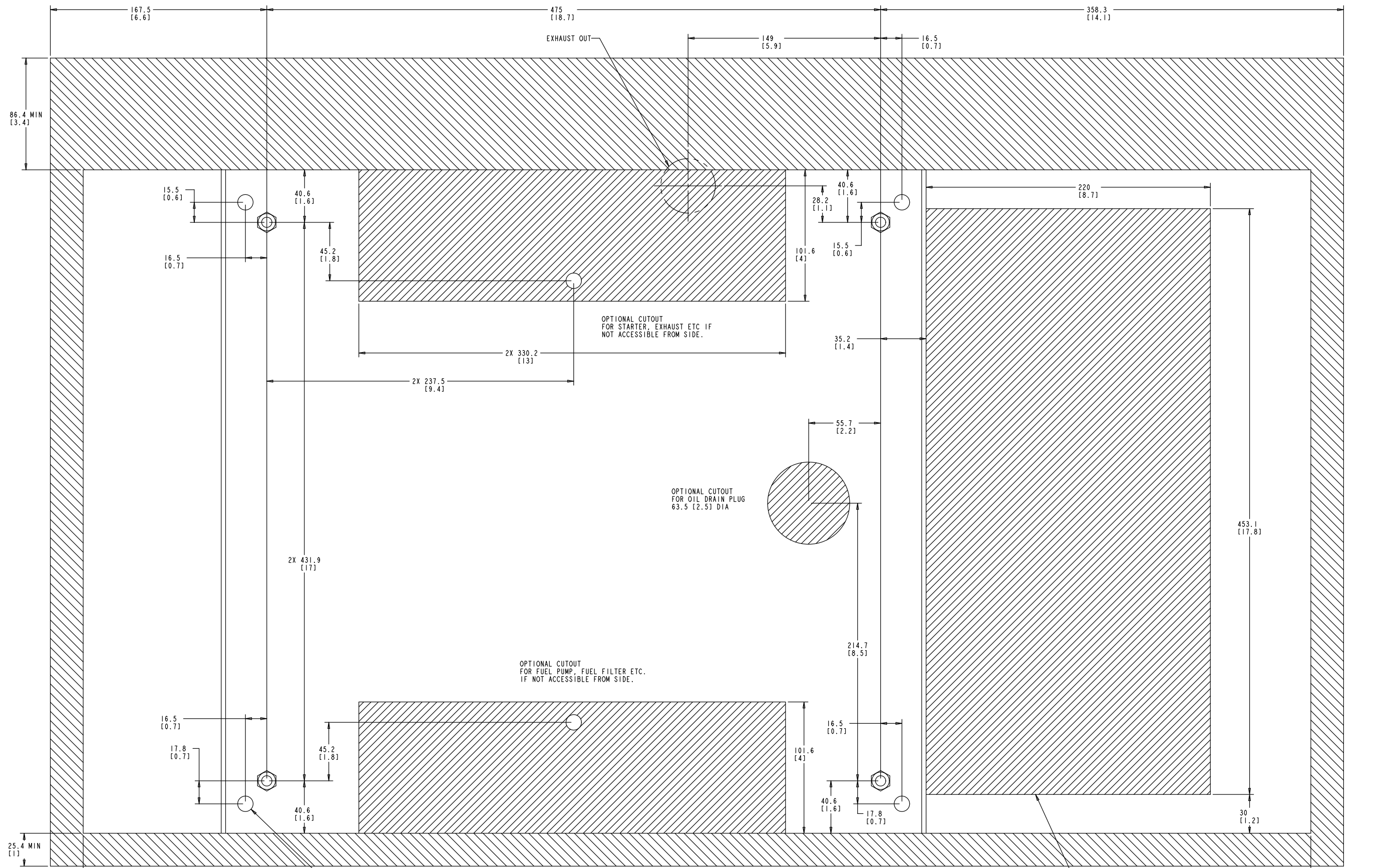
- NOTES:
1. DIMENSIONS IN [ ] ARE INCHES.
  2. WEIGHT: 222KG (490 LBS)
  3. CENTER OF GRAVITY DIMENSIONED IS FOR 0500\_3288\_01, 60 HZ ONLY.
  4. MATING REMOTE CONNECTOR
- | DESCRIPTION    | ONAN PART NO. | PACKARD PART NO. |
|----------------|---------------|------------------|
| CONNECTOR-RCPT | 323-1710      | 12045808         |
| TERMINAL-PIN   | 323-1707      | 12045773         |
| SEAL-CABLE     | 323-1708      | 12048086         |
| CAVITY-SEAL    | 323-1712      | 12059168         |
| HOUSING-LOCK   | 323-1719      | 12124264         |



TABULATION		
DIM.A	GENERATOR LENGTH	DESCRIPTION
947 [37.29]	117 [4.6]	60 HZ, 1Ø, 3Ø
972 [38.27]	142 [5.6]	50 HZ, 1Ø, 3Ø



GENSET OUTLINE DRAWING

0500\_3288



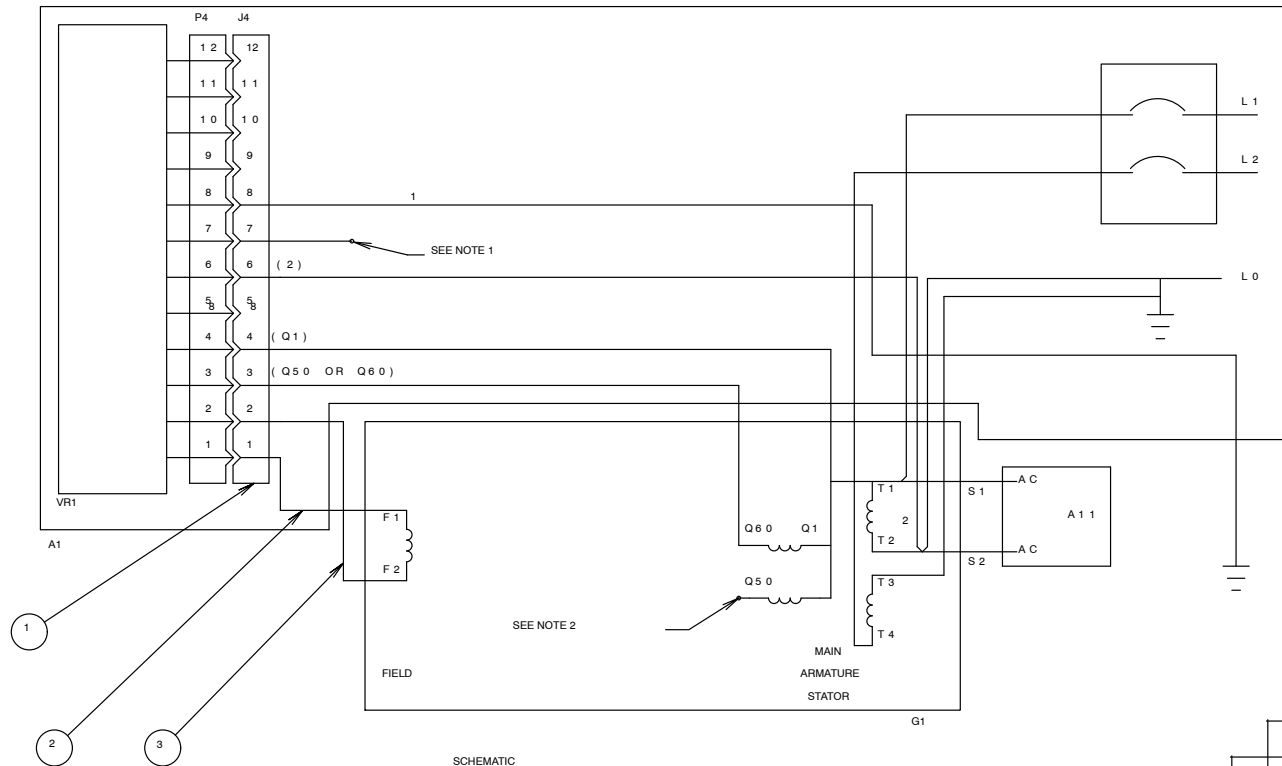
NOTE:  
 1. A 76.2 mm [3 INCH] CLEARANCE IS REQUIRED BETWEEN HOT EXHAUST COMPONENTS AND ANY COMBUSTIBLE MATERIALS.  
 2. DIMENSIONS IN [ ] ARE INCHES.

**GENSET FLOOR TEMPLATE—PLAN VIEW**

 MINIMUM CLEARANCE  
 OPTIONAL CUTOUTS  
 OPTIONAL CUTOUT FOR OIL DRAIN, OIL FILTER, COOLANT DRAIN ETC. IF NOT ACCESSIBLE FROM SIDE

0539\_1962



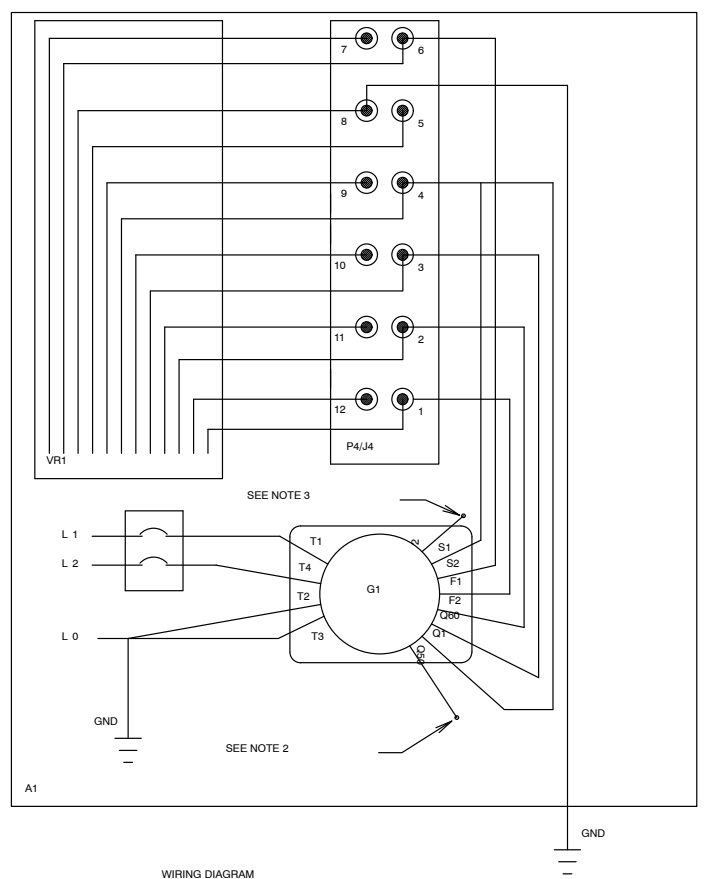


SCHMATIC  
110/220V, 115/230V & 120/240V AS SHOWN  
SEE RECONNECTION CHART FOR OTHER VOLTAGES

REF DES	PART NO	DWG SIZE	QTY	DESCRIPTION
1	---	--	1	WIRE HARNESS
2	---	--	1	LEAD (F1)
3	---	--	1	LEAD (F2)
G1	---	--	1	GENERATOR
VR1	---	--	1	VOLTAGE REG-CAP AVR
---	---	--	---	---
---	---	--	---	---
---	---	--	---	---
---	---	--	---	---
---	---	--	---	---

NOTE:  
1. FROM J2-15 FOR FIELD FLASHING.  
2. QUADRATURE POWER CONNECTION Q60-60 HZ, Q50-50 HZ UNITS.

### 3. AVR REFERENCE VOLTAGE.

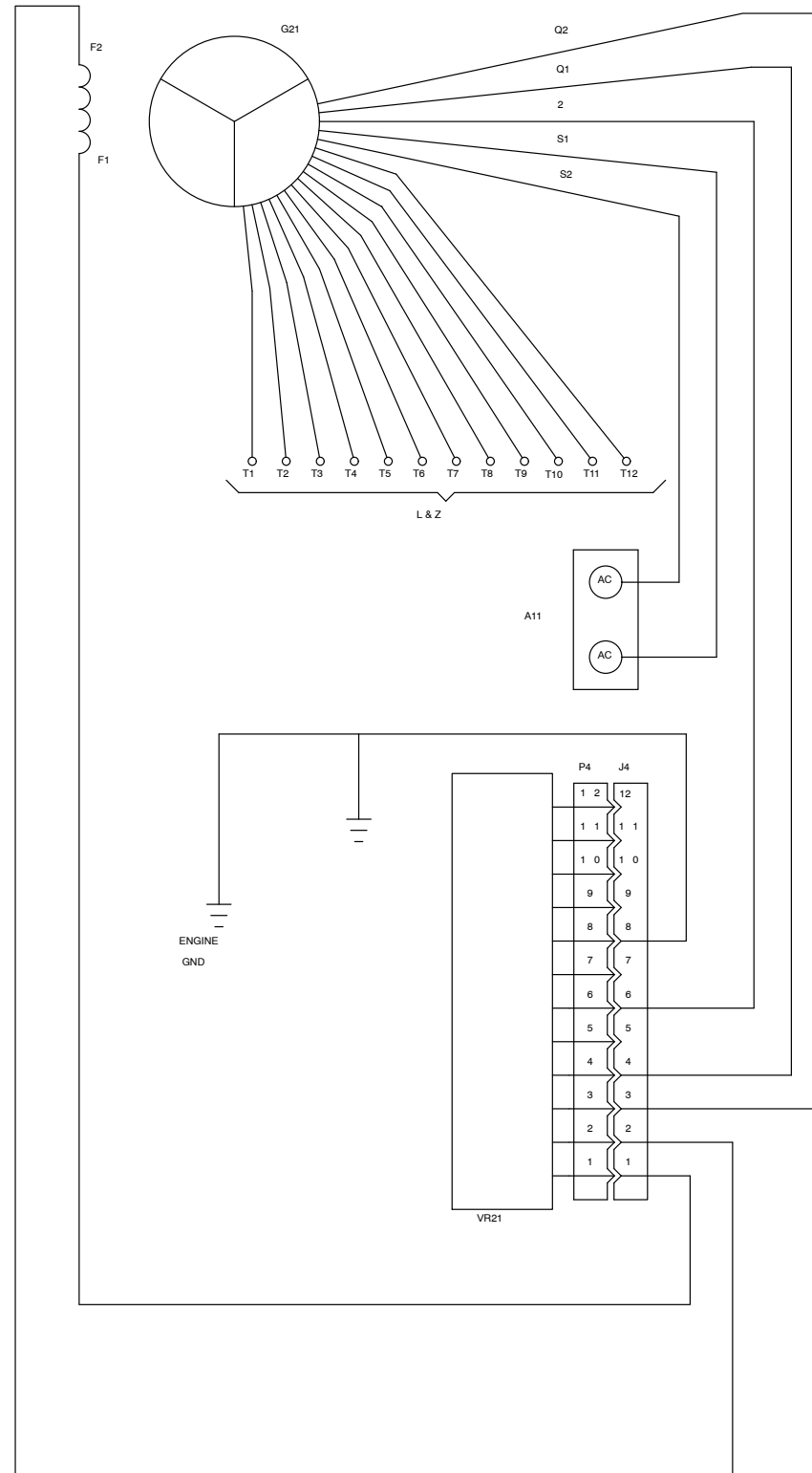
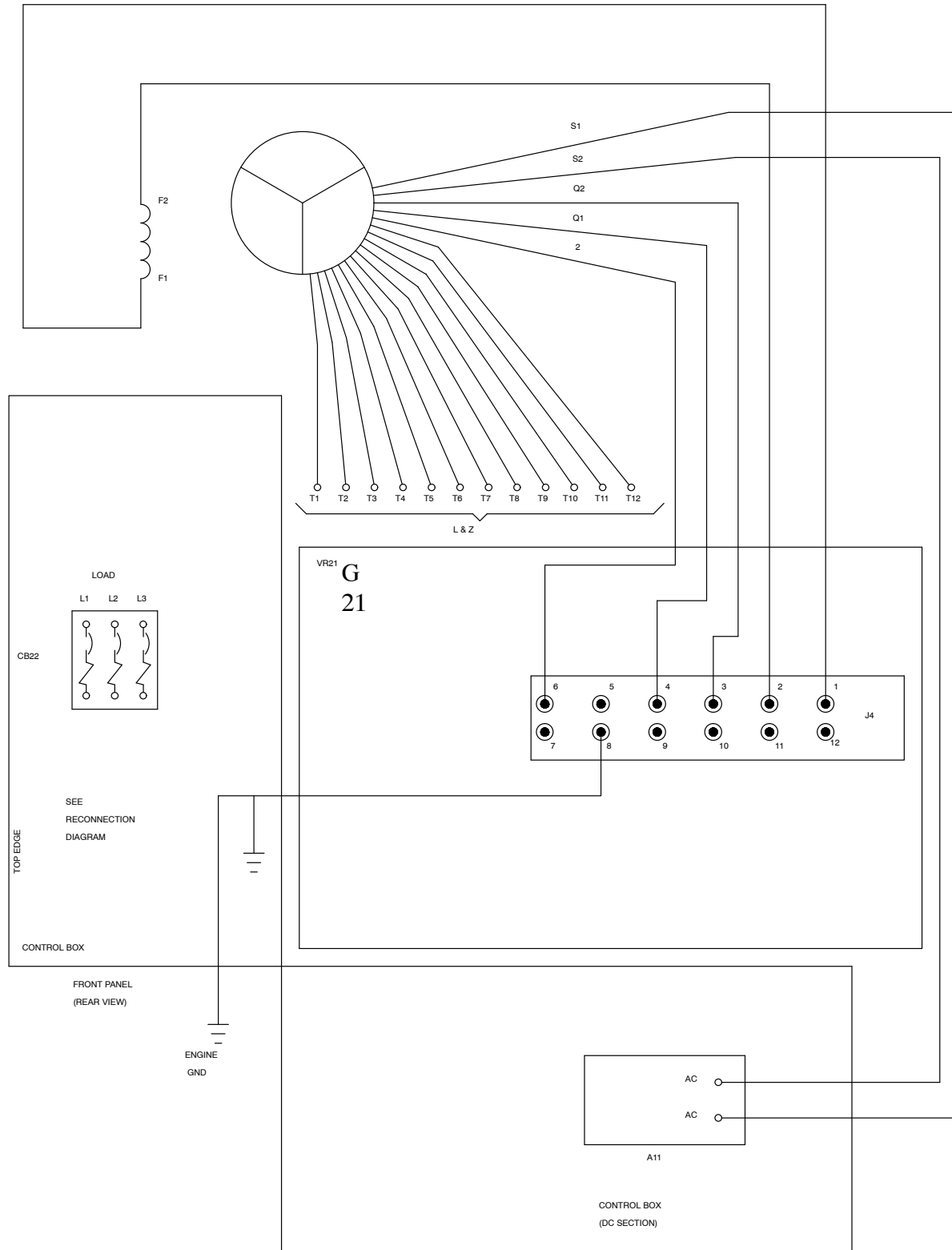


WIRING DIAGRAM  
110/220V, 115/230V & 120/240V AS SHOWN  
SEE RECONNECTION CHART FOR OTHER VOLTAGES

	A	B	C	HZ	CODE
VOLTAGE	100 120	200 240	100/200 120/240	60	J
	110 115	220 230	110/220 115/230	50	P
SCHEMATIC					
	DIAGRAM				

GENERATOR  
RECONNECTION CHART

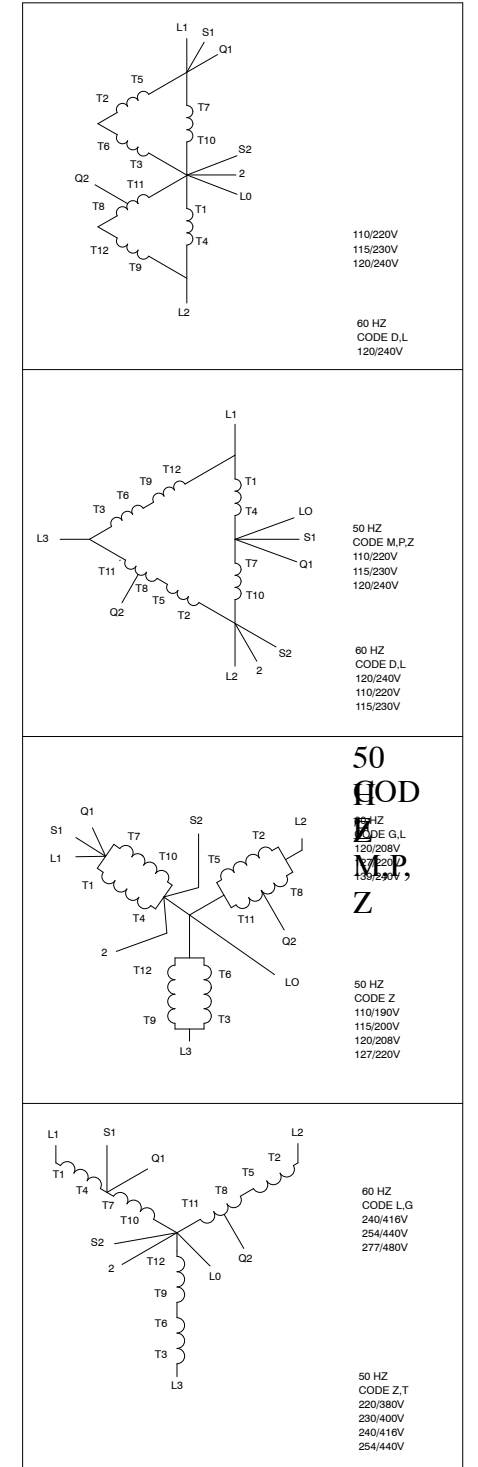
### SINGLE-PHASE AC DIAGRAMS



NOTE:

1. UNLESS OTHERWISE NOTED, ALL COMPONENTS ARE SHOWN IN DE-ENERGIZED POSITION.
2. DASHED LINES INDICATE CONNECTIONS WHEN USED.
3. INSULATE ALL UNUSED OR INTERCONNECTED GENERATOR LEADS WITH SLEEVING AND SECURE WITH CABLE TIE.

RECONNECTION CHART



THREE-PHASE AC DIAGRAMS



[power.cummins.com](https://power.cummins.com)

Copyright © 2024 Cummins Inc. All rights reserved.

Cummins, Onan, and the "C" logo are registered trademarks of Cummins Inc. and its subsidiaries.

Other company, product, or service names may be trademarks or service marks of others.

Specifications are subject to change without notice.

