

Cummins **Onan**



# Operator Manual

## Commercial Mobile Generator Set

HDKBL (Spec A-C)  
HDKBM (Spec A-C)  
HDKBN (Spec A-C)  
HDKBP (Spec A-B)  
HDKBR (Spec A-B)  
HDKBV (Spec A-B)

**CALIFORNIA**  
**Proposition 65 Warning**

**Diesel engine exhaust and some of its constituents are known to the State of California to cause cancer, birth defects, and other reproductive harm.**

# Table of Contents

---

1. IMPORTANT SAFETY INSTRUCTIONS .....	1
1.1 Overview .....	1
1.2 Warning, Caution, and Note Styles Used in This Manual .....	1
1.3 General Safety Precautions .....	1
1.4 Automatic Generator Start Control Hazards .....	3
1.5 Electrical Shock and Arc Flash Can Cause Severe Personal Injury or Death .....	3
1.6 Generator Voltage Is Deadly .....	4
1.7 Engine Exhaust/Carbon Monoxide Is Deadly .....	4
1.8 Diesel Fuel Is Combustible .....	5
1.9 Battery Gas Is Explosive .....	5
1.10 Moving Parts Can Cause Severe Personal Injury or Death .....	6
1.11 CARB .....	6
1.12 Generator Set Warning Labels .....	6
2. INTRODUCTION .....	9
2.1 About this Manual .....	9
2.2 Related Literature .....	9
2.3 Model Identification .....	10
2.3.1 Nameplate Location .....	10
2.4 How to Obtain Service .....	10
2.4.1 In U.S. and Canada .....	10
2.4.2 Outside U.S. and Canada .....	11
2.4.3 Information To Have Available .....	11
2.5 Manufacturing Facilities .....	11
3. OVERVIEW .....	13
3.1 Electromagnetic Compatibility Compliance .....	13
3.2 Information for Generator Set Users .....	13
3.3 Build Standards .....	13
3.4 Specifications .....	15
3.4.1 Diesel Model Specifications .....	15
3.5 List of Acronyms .....	18
4. OPERATION .....	21
4.1 Key Component Locations .....	21
4.2 Control Panel .....	24
4.2.1 Generator Set Control Panel .....	24
4.2.2 Digital Display .....	25
4.2.3 Remote Control Panel .....	29
4.3 Starting and Stopping the Generator Set .....	31
4.3.1 Pre-start Checks .....	31
4.3.2 Priming the Fuel System .....	31
4.3.3 Starting the Generator Set .....	32

---

4.3.4 Stopping the Generator Set .....	32
4.4 Loading the Generator Set .....	32
4.4.1 Power Versus Altitude .....	34
4.5 Exercising the Generator Set .....	35
4.6 Resetting Line Circuit Breakers .....	35
4.7 Connecting Shore Power .....	36
4.8 Operating in Weather Extremes .....	36
4.9 Operating in Dusty Environments .....	37
4.10 Care of New or Rebuilt Engine .....	37
5. MAINTENANCE .....	39
5.1 Periodic Maintenance .....	39
5.1.1 Periodic Maintenance Schedule .....	39
5.2 Consumable Parts .....	40
5.3 General Inspection .....	40
5.4 Maintaining the Battery .....	41
5.5 Maintaining the Lubrication System .....	41
5.5.1 Oil Level .....	41
5.5.2 Engine Oil Recommendations .....	42
5.5.3 Changing Engine Oil and Oil Filter .....	43
5.6 Maintaining the Fuel System .....	46
5.6.1 Fuel System .....	46
5.6.2 Fuel Recommendations .....	46
5.6.3 Draining the Fuel Filter .....	48
5.6.4 Replacing the Fuel Filter .....	48
5.6.5 Replacing the Fuel Filter .....	49
5.7 Maintaining the Cooling System .....	51
5.7.1 Cooling System – HDKBL .....	51
5.7.2 Cooling System – HDKBM, HDKBN .....	53
5.7.3 Cooling System – HDKBP, HDKBR, HDKBV .....	55
5.7.4 Pressure Cap .....	56
5.7.5 Coolant Hoses .....	57
5.7.6 Coolant Level .....	57
5.7.7 Coolant Recommendations .....	57
5.7.8 Replenishing Normal Coolant Loss .....	58
5.7.9 Draining and Cleaning Cooling System .....	58
5.7.10 Refilling Cooling System .....	58
5.7.11 Heat Exchanger .....	59
5.7.12 Fan Blades and Motor .....	59
5.7.13 Replacing the Thermostat .....	60
5.7.14 Adjusting V-Belt Tension .....	61
5.8 Exhaust System .....	62
5.9 Mechanical System .....	63
5.10 Replacing the Air Filter Element .....	63
5.11 Storing the Generator Set .....	63
5.12 Returning the Generator Set to Service .....	64

---



---

6. TROUBLESHOOTING .....	65
6.1 Overview .....	65
6.2 Troubleshooting with Digital Display .....	65
6.3 Fault Codes.....	65
6.3.1 Code 1 - Engine Over Temperature .....	66
6.3.2 Code 2 - Low Oil Pressure.....	66
6.3.3 Code 3 - Service Check.....	67
6.3.4 Code 4 - Over Crank.....	67
6.3.5 Code 5 - Warning Shutdown due to CO .....	67
6.3.6 Code 12 - Over Voltage .....	67
6.3.7 Code 13 - Under Voltage .....	67
6.3.8 Code 14 - Over Frequency .....	68
6.3.9 Code 15 - Under Frequency .....	68
6.3.10 Code 19 - Governor Actuator.....	68
6.3.11 Code 22 - Governor Actuator Overload .....	68
6.3.12 Code 24 - Faulty Temperature Sender .....	68
6.3.13 Code 27 - Voltage Sense.....	68
6.3.14 Code 29 - High Battery Voltage .....	69
6.3.15 Code 32 - Low Cranking Speed.....	69
6.3.16 Code 35 - Control Card Failure.....	69
6.3.17 Code 36 - Engine Stopped .....	69
6.3.18 Code 38 - Over Current (Field Overload) .....	70
6.3.19 Code 41 - Generator Rotor .....	70
6.3.20 Code 42 - Processor .....	70
6.3.21 Code 43 - Processor .....	70
6.3.22 Code 45 - Speed Sense .....	70
6.3.23 Code 48 - Generator Field Sense.....	70
6.3.24 Code 57 - Over Prime.....	70
6.3.25 Code 59 - Low Coolant Level .....	71
6.3.26 Code 61 - External Shutdown.....	71
6.4 Symptom Based.....	71
6.4.1 Status Indicator Not Working .....	71
6.4.2 Starting Batteries Run Down.....	71
6.4.3 Starter Engages-Disengages.....	71
6.4.4 No Power—Generator Set Running, Status Light On.....	72
7. MAINTENANCE RECORD.....	73

This page is intentionally blank.

# 1 IMPORTANT SAFETY INSTRUCTIONS

---

## 1.1 Overview

Thoroughly read the Operator Manual before operating the generator set. It contains important instructions that should be followed during operation and maintenance. Safe operation and top performance can only be achieved when equipment is properly operated and maintained. The owners and operators of the generator set are solely responsible for its safe operation.

Generator set operation, maintenance, and installation must comply with all applicable local, state, and federal codes and regulations. Electricity, fuel, exhaust, moving parts, and batteries present hazards which can result in severe personal injury or death. Only trained and experienced personnel with knowledge of fuels, electricity, and machinery hazards should perform generator set installation or adjustment procedures; or remove, dismantle, or dispose of the generator set.

## 1.2 Warning, Caution, and Note Styles Used in This Manual

The following safety styles and symbols found throughout this manual indicate potentially hazardous conditions to the operator, service personnel, or equipment.

 <b>DANGER</b>
<i>Indicates a hazardous situation that, if not avoided, will result in death or serious injury.</i>

 <b>WARNING</b>
<i>Indicates a hazardous situation that, if not avoided, could result in death or serious injury.</i>

 <b>CAUTION</b>
<i>Indicates a hazardous situation that, if not avoided, could result in minor or moderate injury.</i>

<b>NOTICE</b>
Indicates information considered important, but not hazard-related (e.g., messages relating to property damage).

## 1.3 General Safety Precautions

 <b>WARNING</b>
<i>Operation of equipment is unsafe when mentally or physically fatigued. Do not operate equipment in this condition, or after consuming any alcohol or drug.</i>

**⚠ WARNING**

*Maintaining or installing a generator set can cause severe personal injury. Wear personal protective equipment such as safety glasses, protective gloves, hard hats, steel-toed boots, and protective clothing when working on equipment.*

**⚠ WARNING**

*Running the generator set without the cover or service door can cause severe personal injury or equipment damage. Do not operate the generator set with the cover or service doors removed.*

**⚠ WARNING**

*Coolants under pressure can cause severe scalding. Do not open a radiator or heat exchanger pressure cap while the engine is running. Let the engine cool down before removing the coolant pressure cap. Turn the cap slowly and do not open it fully until the pressure has been relieved.*

**⚠ WARNING**

*Hot metal parts can cause severe burns, Avoid contact with the radiator, turbo charger, and exhaust system.*

**⚠ WARNING**

*Starting fluids, such as ether, can cause explosion and generator set engine damage. Do not use.*

**⚠ WARNING**

*Ethylene glycol, used as engine coolant, is toxic to humans and animals. Clean up coolant spills and dispose of used antifreeze in accordance with local environmental regulations.*

**⚠ WARNING**

*Used engine oils have been identified by some state and federal agencies to cause cancer or reproductive toxicity. Do not ingest, breathe the fumes, or contact used oil when checking or changing engine oil.*

**⚠ CAUTION**

*To prevent accidental or remote starting while working on the generator set, disconnect the negative (-) battery cable at the battery using an insulated wrench.*

**⚠ CAUTION**

*Unsecured or loose fasteners can cause equipment damage. Make sure all fasteners are secure and properly torqued.*

**⚠ CAUTION**

*Oily rags and other material can cause fire and restrict cooling. Keep the generator set, drip pan, and compartment clean.*

**⚠ CAUTION**

*Accumulated grease and oil can cause overheating and engine damage presenting a potential fire hazard. Keep the generator set clean and repair any oil leaks promptly.*

**NOTICE**

Keep multi-class ABC fire extinguishers handy. Class A fires involve ordinary combustible materials such as wood and cloth. Class B fires involve combustible and flammable liquid fuels and gaseous fuels. Class C fires involve live electrical equipment. (Refer to NFPA No. 10 in applicable region.)

## 1.4 Automatic Generator Start Control Hazards

**⚠ WARNING**

*Accidental starting can cause severe personal injury or death. Turn off the AGS whenever performing maintenance or service, when the vehicle is stored between uses, is awaiting service, or is parked in a garage or other confined area.*

Unexpected starting may occur if the generator set is equipped with an inverter-charger or other Automatic Generator Start (AGS) control. This may cause exposure to:

- Unexpected generator starting
- Moving parts hazards
- Electric shock
- Exhaust carbon monoxide (CO)

## 1.5 Electrical Shock and Arc Flash Can Cause Severe Personal Injury or Death

**⚠ WARNING**

*Electrical shocks and arc flashes can cause severe personal injury or death. Adhere to the following guidelines:*

- *Only qualified service personnel certified and authorized to work on power circuits should work on exposed energized power circuits.*
- *All relevant service material must be available for any electrical work performed by certified service personnel.*
- *Exposure to energized power circuits with potentials of 50 VAC or 75 VDC or higher poses a significant risk of electrical shock and electrical arc flash.*
- *Refer to standard NFPA 70E, or equivalent safety standards in corresponding regions, for details of the dangers involved and for safety requirements.*

## 1.6 Generator Voltage Is Deadly

### WARNING

*Improperly connected generator electrical output connections can cause equipment damage, severe personal injury, or death. Electrical connections must be made by a trained and experienced electrician in accordance with applicable codes.*

### WARNING

*Improper installations can cause equipment damage, severe personal injury, or death. All installations must be conducted by trained and experienced personnel in accordance with the installation instructions and all applicable codes.*

### WARNING

*Back feed to shore power can cause electrocution and damage to equipment. The generator set must not be connected to shore power or to any other source of electrical power. An approved switching device must be used to prevent interconnections.*

### WARNING

*Live electrical equipment can cause electrocution. Use caution when working on live electrical equipment. Remove jewelry, make sure clothing and shoes are dry, stand on a dry wooden platform or rubber insulating mat, and use tools with insulated handles.*

## 1.7 Engine Exhaust/Carbon Monoxide Is Deadly

### WARNING

*Substances in exhaust gases have been identified by some state and federal agencies to cause cancer or reproductive toxicity. Do not breathe in or come into contact with exhaust gases.*

### WARNING

*Carbon monoxide is a poisonous gas. Inhalation of this gas can cause severe personal injury or death. Adhere to the following bullet points to make sure carbon monoxide is not being inhaled by occupants of the vehicle as well as others working on or around the generator set.*

- *Inspect for exhaust leaks, and test and confirm that all carbon monoxide detectors are working in accordance with the manufacturer's instructions or owner's manual, prior to every startup, and after every 8 hours of running.*
- *Never occupy the vehicle while the generator set is running unless the vehicle is equipped with a working carbon monoxide detector.*
- *Never operate the generator set when the vehicle is in a confined space, such as a garage, basement, or building of any kind.*
- *Make sure the exhaust system is installed in accordance with the generator set installation manual.*
- *Never use engine cooling air for heating a working or living space compartment.*

Carbon Monoxide (CO) is odorless, colorless, tasteless, and non-irritating. It cannot be seen or smelled. Exposure, even to low levels of CO for a prolonged period can lead to asphyxiation (lack of oxygen).

Mild effects of CO poisoning include:

- headache
- dizziness
- drowsiness
- fatigue
- chest pain
- confusion

More extreme symptoms include:

- vomiting
- seizure
- loss of consciousness

## 1.8 Diesel Fuel Is Combustible

### WARNING

*Diesel fuel is highly combustible. Adhere to the following bullets to avoid igniting fuel and fuel vapors.*

- *Do not smoke or turn electrical switches on or off where fuel fumes are present or in areas sharing ventilation with fuel tanks or equipment.*
- *Keep flame, sparks, pilot lights, arc-producing equipment and all other sources of ignition well away from fuel lines and sources.*
- *Fuel lines must be secured, free of leaks, and separated or shielded from electrical wiring.*

### WARNING

*Flammable vapor can cause a diesel engine to over speed and become difficult to stop, resulting in possible fire or explosion, and severe personnel injury or death. Do not operate a diesel-powered generator set where a flammable vapor environment can be created by fuel spill, leak, etc.*

## 1.9 Battery Gas Is Explosive

### WARNING

*Battery gas is highly explosive and may cause personal injury or death if ignited. Take the proper precautions to avoid personal injury.*

- *For personal safety, wear appropriate PPE when working on or around the generator set.*
- *To make sure battery gas is not ignited, do not smoke around the generator set.*
- *To reduce arcing when disconnecting or reconnecting battery cables, always disconnect the negative (-) battery cable first and reconnect it last.*

## 1.10 Moving Parts Can Cause Severe Personal Injury or Death

### WARNING

*Moving parts can cause severe personal injury or death, and hot exhaust parts can cause severe burns. Make sure all protective guards are properly in place before starting the generator set.*

### WARNING

*Hot moving, and electrically live parts can cause severe personal injury or death. Keep children away from the generator set.*

### WARNING

*Hot, moving, and electrically live parts can cause severe personal injury or death. Only trained and experienced personnel should make adjustments while the generator set is running.*

### WARNING

*Moving parts can catch on loose items such as clothing or jewelry. Do not wear loose clothing or jewelry near moving parts such as PTO (power take-off) shafts, fans, belts, and pulleys.*

### WARNING

*Moving parts can entangle appendages such as fingers. Keep the protective guards in place over fans, belts, pulleys, and other moving parts and keep hands away from all moving parts.*

## 1.11 CARB

### CAUTION











*Unauthorized modifications or replacement of fuel, exhaust, air intake, or speed control system components that affect engine emissions are prohibited by law in the state of California.*

The California Air Resources Board (CARB) has requirements regarding modification & repair of fuel system & exhaust components including, but not limited to, adherence to evaporative emissions requirements in mobile installations. Evaporative generator sets must be used in trailers, fifth wheel trailers, and other non-motorized vehicles where on-board gasoline fuel storage is self-contained in the trailer equipment. Completing the installation of the generator set fuel evaporative system provides compliance with the California code of regulations for small off-road equipment effective January 1, 2008 and Federal Small SI regulation effective January 1, 2011. Any questions regarding the installation or evaporative emission certification should be directed to Cummins Inc. for clarification.

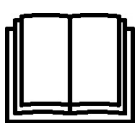
## 1.12 Generator Set Warning Labels

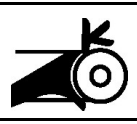
Warning signs are provided on the generator set at or near the point of risk. To avoid injury, always take the necessary precautions as indicated on the sample signs shown below.



	Caution or Warning. Indicates a risk of personal injury.
	Caution or Warning of Temperature Hazard. Indicates a risk of personal injury from high temperature.
	Caution or Warning of High Voltage Hazard. Indicates a risk of personal injury from electric shock or electrocution.
	Caution or Warning of Engine Coolant Pressure Hazard. Indicates a risk of personal injury from hot pressurized engine coolant.
	Caution or Warning. Indicates to read Operator Manual for additional information.
	Caution or Warning of No Step. Indicates a risk of personal injury or equipment damage from stepping on equipment.
	Caution or Warning of Combustion or Explosion Hazard. Indicates a risk of personal injury from explosion.
	Caution or Warning of Belt and Rotating Part Hazard. Indicates a risk of personal injury from entanglement in moving parts.
	Caution or Warning of Chemical (ingestion or burn) Hazard. Indicates a risk of personal injury or asphyxiation from poisonous fumes or toxic gases.
	Caution or Warning of High Voltage or Current Source Hazard. Indicates a risk of personal injury from electrical shock or electrocution.
	Caution or Warning of Fan and Rotating Part Hazard. Indicates a risk of personal injury from entanglement in moving parts.

This page is intentionally blank.

# 2 Introduction

---

## 2.1 About this Manual

This is the Operator Manual for the generator set or sets listed on the front cover. Each operator should study this manual carefully and observe all of its instructions and safety precautions. Keep this manual readily available for reference.

The information contained within the manual is based on information available at the time of printing. In line with Cummins Inc. policy of continuous development and improvement, information may change at any time without notice. The users should therefore make sure that before commencing any work, they have the latest information available. The latest version of this manual is available on QuickServe Online (<https://quickserve.cummins.com>).

The Operation, Maintenance, and Troubleshooting Chapters of this manual provide instructions necessary for operating the generator set and maintaining it at top performance. The owner is responsible for performing maintenance in accordance with the information provided in [Chapter 5 on page 39](#).

This manual also includes generator set specifications and information on how to obtain service, emissions regulation compliance, and model identification.

See the Parts Manual for part identification numbers and required quantities. Genuine Cummins replacement parts are recommended for best results.

## 2.2 Related Literature

Before any attempt is made to operate the generator set, the operator should take time to read all of the manuals supplied with the generator set, and to familiarize themselves with the warnings and operating procedures.

### CAUTION

***A generator set must be operated and maintained properly if you are to expect safe and reliable operation. The Operator manual includes a maintenance schedule and a troubleshooting guide. The Health and Safety manual must be read in conjunction with this manual for the safe operation of the generator set:***

- Health and Safety Manual (0908-0110)

The relevant manuals appropriate to your generator set are also available, the documents below are in English:

- Operator Manual (A041K811)
- Installation Manual (A041K812)
- Generator Set Service Manual (A041K813)
- Recommended Spares List (RSL) for Commercial Mobile Generator Set HDKBL, HDKBM, HDKBN, HDKBP, HDKBR, and HDKBV (Spec A) (A043W861)
- Parts Manual for Commercial Mobile Generator Set HDKBL, HDKBM, and HDKBN (Spec A) (A041K815); HDKBP, HDKBR, and HDKBV (Spec A) (A041T393)
- Standard Repair Times - EI Family (A049M494)
- Service Tool Manual (A043D529)

- Failure Code Manual (F1115C)
- Engine Operation & Maintenance Manual for Kubota 03-M-E3B and E3BG and 03-M DI-E3B (0981-0551)
- Warranty Manual (A040W374)
- Global Commercial Warranty Statement (A028U870)

## 2.3 Model Identification

Each generator set is provided with a nameplate that contains the model and serial numbers. This information is needed when contacting Cummins for parts, service, and product information.

Every character of the model number is significant. The last character of the model number is the specification letter which is important for obtaining the correct parts.

Record the generator set model and serial numbers in the figure below to have them available if needed.

### 2.3.1 Nameplate Location

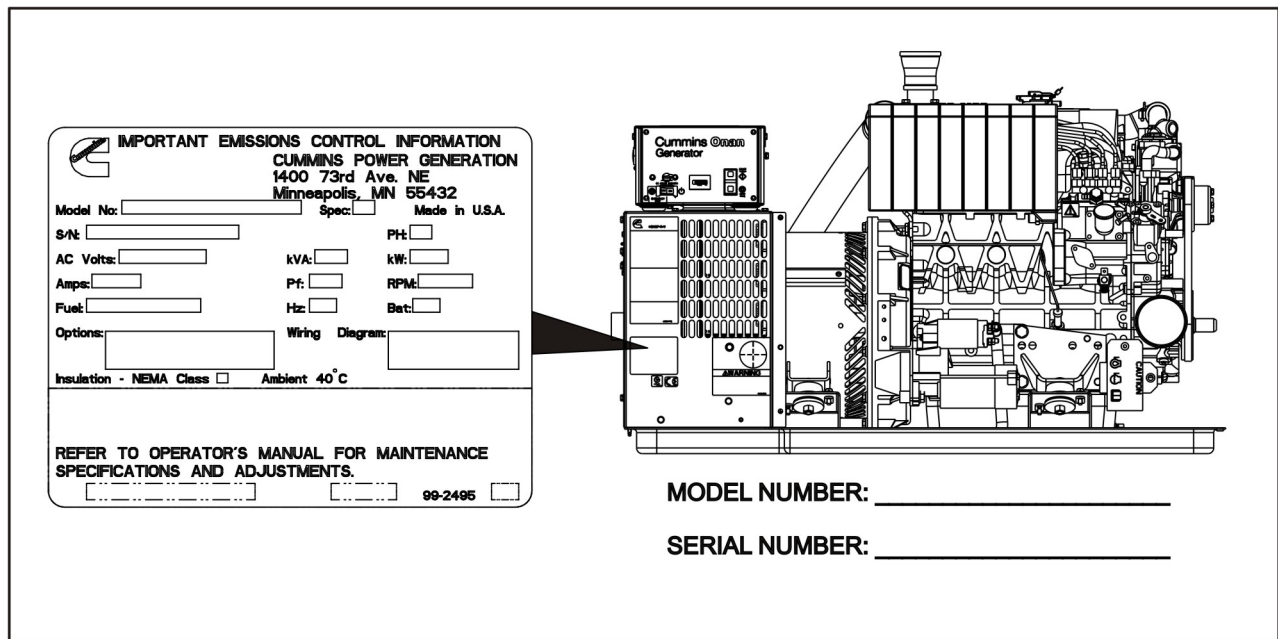

FIGURE 1. TYPICAL NAMEPLATE LOCATION

## 2.4 How to Obtain Service

For generator set parts, service, and literature, contact the nearest authorized Cummins Inc. distributor. You may go to the Internet site [power.cummins.com](http://power.cummins.com) for information on contacting our distributors worldwide.

### 2.4.1 In U.S. and Canada

Call +1-800-CUMMINS™ (1-800-286-6467) for the nearest Cummins Inc. distributor in the United States or Canada. Press 1 (option 1) to be automatically connected.

If you are unable to contact a distributor using the automated service, consult the Yellow Pages. Typically, our distributors are listed under: generators - electric.

## 2.4.2 Outside U.S. and Canada

If you are outside U.S. and Canada, refer to [power.cummins.com](http://power.cummins.com) or send an email to [ask.powergen@cummins.com](mailto:ask.powergen@cummins.com).

## 2.4.3 Information To Have Available

- model number
- serial number
- date of purchase
- nature of the problem (see [Chapter 6 on page 65](#))

## 2.5 Manufacturing Facilities

U.S. and CANADA	EMEA, CIS	BRAZIL
Cummins Inc. 1400 73rd Ave. NE Minneapolis, MN 55432 USA	Cummins Inc. Royal Oak Way South Daventry Northamptonshire NN11 8NU United Kingdom	Rua Jati, 310, Cumbica Guarulhos, SP 07180-900 CNPJ: 43.2201.151/0001-10 Brazil
Toll Free 1-800-CUMMINS™ (1-800-286-6467) Fax +1 763-574-5298	Phone +44 1327 88-6453 Fax +44 1327 88-6125	Phone 0800 286 6467
CHINA	INDIA	ASIA PACIFIC
Cummins Inc. No.118 South Quanli Road , Wuhan Economic& Technological Development Zone , Hubei, P.R.China 430058	Cummins Inc. Plot No B-2, SEZ Industrial Area, Village-Nandal & Surwadi, Taluka- Phaltan Dist- Satara, Maharashtra 415523 India	Cummins Sales and Service Singapore Pte Ltd 85 Tuas South Avenue 1 Singapore 637419
Phone + 86 (27) 8421 4008 Fax + 86 (27) 8421 4804	Phone +91 021 66305514	Fax +65 6265 6909
LATIN AMERICA	MEXICO	
3350 Southwest 148th Ave. Suite 205 Miramar, FL 33027 USA	Eje 122 No. 200 Zona Industrial San Luis Potosi, S.L.P. 78395 Mexico Eje 120 No. 201 Zona Industrial San Luis Potosi, S.L.P. 78395 Mexico	
Phone +1 954 431 551 Fax +1 954 433 5797	Phone +52 444 870 6700 Fax +52 444 824 0082	

This page is intentionally blank.

# 3 Overview

---

## 3.1 Electromagnetic Compatibility Compliance

Generator sets emit and receive electromagnetic (radio frequency) energy. If the generator set affects operation of nearby devices, or nearby devices affect generator set operation, increase the distance between them.

When used in countries where compliance to the EMC directive is required: This generator set has been evaluated for use in the residential, commercial, and light industrial environments.

## 3.2 Information for Generator Set Users

This generator set meets the requirements of California Air Resources Board (CARB) as stated on the nameplate.

As a user of this generator set, please be aware that unauthorized modifications or replacement of fuel, exhaust, air intake, or speed control system components that affect engine emissions are prohibited. Unauthorized modification, removal, or replacement of the generator set label is prohibited.

Carefully review Operator (Owner), Installation, and other manuals and information you receive with the generator set. If unsure that the installation, use, maintenance, or service of the generator set is authorized, seek assistance from an approved Cummins dealer.

Generator set users may use the following table as an aid in locating information related to the CARB requirements for emissions control.

**TABLE 1. EMISSIONS CONTROL INFORMATION**

Generator Set Warranty Information	The emissions control warranty statement is located in the same packet of information as this manual when the generator set is shipped from the factory.
Engine Valve Lash	See <a href="#">Section 3.4 on page 15</a> .
Engine Fuel Requirements	The engine is certified to operate on diesel fuel. See <a href="#">Section 5.6 on page 46</a> for fuel recommendations.
Engine Lubricating Oil Requirements	See <a href="#">Section 5.5 on page 41</a> for engine oil recommendations.
Engine Adjustments	High idle speed. This is a service procedure requiring trained personnel and proper tools. See the Service Manual.
Engine Emission Control System	The engine emissions control system consists of engine design and precision manufacture (IFI).

## 3.3 Build Standards

The generator set and its control system have been designed, constructed and tested generally in accordance with the following Standards where applicable.

Standard	Title
BS EN 1037:1995+a1:2008	Safety of machinery - Prevention of unexpected start up.

Standard	Title
BS EN ISO 14121-1:2007	Safety of machinery. Risk assessment principles.
BS EN ISO 13857:2008	Safety of machinery. Safety distances to prevent hazard zones being reached by upper and lower limbs.
BS EN 349:1993+A1:2008	Safety of machinery - Minimum gaps to avoid crushing parts on the human body.
BS EN 547-1:1996+A1:2008	Safety of machinery - Human body dimensions - Part 1: Principles for determining the dimensions required for openings for whole body access into machinery.
BS EN 547-2:1996+A1:2008	Safety of machinery - Human body dimensions - Part 2: Principles for determining the dimensions required for access openings.
BS EN 547-3:1996+A1:2008	Safety of machinery - Human body dimensions - Part 3: Anthropomorphic data.
BS EN 60204-1:2006+A1:2009	Safety of machinery. Electrical equipment of machines. General requirements.
BS EN 614-1:2006+A1:2009	Safety of machinery. Ergonomic design principles. Terminology and general principles.
BS EN 953:1997+A1:2009	Safety of machinery - Guards - General requirements for the design and construction of fixed and movable guards.
BS EN ISO 12100-1:2003+A1:2009	Safety of machinery. Basic concepts, general principles for design. Basic terminology, methodology
BS EN ISO 12100-2:2003+A1:2009	Safety of machinery. Basic concepts, general principles for design. Technical principles
BS EN ISO 13732-1:2008	Ergonomics of the thermal environment. Methods for the assessment of human responses to contact with surfaces. Hot surfaces
BS EN ISO 13849-1:2008	Safety of machinery - Safety-related parts of control systems
BS EN ISO 13850:2006	Safety of machinery - Emergency stop. Principles for design.
BS EN 61310-1:2008	Safety of machinery - Indication, marking and actuation - Part 1: Requirements for visual, auditory and tactile signals.
BS EN 61310-2:2008	Safety of machinery - Indication, marking and actuation - Part 2: Requirements for marking.
BS EN 61000-6-1:2007	Electromagnetic compatibility (EMC). Generic standards. Immunity standard for residential, commercial and light-industrial environments.
BS EN 61000-6-3:2007	Electromagnetic compatibility (EMC). Generic standards. Emission standard for residential, commercial and light-industrial environments.
BS EN 1299:1997+A1:2008	Mechanical vibration and shock - Vibration isolation of machines - Information for the application of source isolation
BS EN 1679-1:1998	Reciprocating internal combustion engines - Safety - Part 1: Compression ignition engines
BS EN 12601:2001	Reciprocating internal combustion engine driven generating sets - Safety



## 3.4 Specifications

### 3.4.1 Diesel Model Specifications

TABLE 2. HDKBL, HDKBM, HDKBN SPECIFICATIONS

	HDKBL	HDKBM	HDKBN
<b>GENERATOR:</b> Single-Bearing, 4-Pole Rotating Field, Brushless			
Power (@1.0 power factor)	7000 Watts	9500 Watts	11,000 Watts
Frequency	50 Hz	50 Hz	50 Hz
<b>FUEL CONSUMPTION:</b>			
No Load	0.8 l/h (0.2 gph)	0.8 l/h (0.2 gph)	0.8 l/h (0.2 gph)
Half Load	1.5 l/h (0.4 gph)	2.3 l/h (0.6 gph)	2.3 l/h (0.6 gph)
Full Load	3 l/h (0.8 gph)	3.4 l/h (0.9 gph)	3.8 l/h (1 gph)
<b>ENGINE:</b> Kubota 4-Stroke Cycle, Indirect Injection (IDI), Water-cooled Diesel with Digital Electronic Governing			
Model	D1105	V1505	V1505
Rated RPM	1500	1500	1500
Number of Cylinders	3	4	4
Bore	78 mm (3.07 in)		
Stroke	78.4 mm (3.09 in)		
Displacement	1,123 cm <sup>3</sup> (68.53 in <sup>3</sup> )	1,498 cm <sup>3</sup> (91.41 in <sup>3</sup> )	
Compression Ratio	24 : 1		
Oil Capacity	4 liters (4.2 qt)	4.3 liters (4.5 qt)	
<b>Maximum Angularity any Direction:</b>			
Continuous	10°		
Intermittent	22.5°		
<b>COOLING:</b>			
Generator Set Coolant Capacity	4 liters (4.2 qt)	5.6 liters (5.9 qt)	
Remote Heat Exchanger Coolant Capacity	3.3 liters (3.5 qt)	3.7 liters (3.9 qt)	
Coolant Flow Rate	24.6 l/min (6.5 gal/min)		
Heat Rejection to Coolant	197 kcal/min (780 BTU/min)	227 kcal/min (900 BTU/min)	252 kcal/min (1000 BTU/min)
Thermostat Opening Temperature	71 °C (159.8 °F)		
Thermostat Fully Open Temperature	85 °C (185 °F)		
Recommended Pressure Cap	48 kPa (7 psi)		
<b>GENERATOR SET AIR FLOW:</b>			

	HDKBL	HDKBM	HDKBN
Combustion Air Flow	0.71 m <sup>3</sup> /min (25 ft <sup>3</sup> /min)	0.96 m <sup>3</sup> /min (34 ft <sup>3</sup> /min)	
Heat Rejection to Ambient	45 kcal/min (179 BTU/min)	53 kcal/min (210 BTU/min)	
<b>EXHAUST:</b>			
Maximum Exhaust Back Pressure	3 in Hg	3 in Hg	3 in Hg
Exhaust Gas Flow	2.5 m <sup>3</sup> /min (90 ft <sup>3</sup> /min)	3.3 m <sup>3</sup> /min (118 ft <sup>3</sup> /min)	
<b>DC SYSTEM:</b>			
Nominal Battery Voltage	12/24 VDC		
Minimum Battery Capacity CCA (Cold Cranking Amps)	500 Amps at 0 °C (32 °F) 12 VDC	540 Amps at 0 °C (32 °F) 12 VDC	
Battery Recharging	Installer must provide	Installer must provide	Installer must provide
<b>Net Battery Charging Output:</b>			
12 Volt Negative Ground	2 Amps		
24 Volt Negative Ground	13 Amps		
<b>INSTALLATION:</b>			
Generator Set Dry Weight (with sound shield)	272 kg (600 lbs)	315 kg (695 lbs)	
Remote Heat Exchanger Dry Weight (with sound shield)	21 kg (47 lbs)	30 kg (67 lbs)	
Size (L x W x H)	911 x 566 x 593 mm (35.9 x 22.3 x 23.4 in)	1033 x 566 x 593 mm (40.7 x 22.3 x 23.4 in)	
Sound	60 dB(A) @ 3 m (10 ft)—with sound shield at full load	62 dB(A) @ 3 m (10 ft)—with sound shield at full load	62 dB(A) @ 3 m (10 ft)—with sound shield at full load

TABLE 3. HDKBP, HDKBR, HDKBV SPECIFICATIONS

	HDKBP	HDKBR	HDKBV
<b>GENERATOR:</b> Single-Bearing, 4-Pole Rotating Field, Brushless			
Power (@1.0 power factor)	13,500 Watts	17,500 Watts	19,000 Watts
Frequency	50 Hz	50 Hz	50 Hz
<b>FUEL CONSUMPTION:</b>			
No Load	1.1 l/h (0.3 gph)	1.1 l/h (0.3 gph)	1.1 l/h (0.3 gph)
Half Load	2.6 l/h (0.7 gph)	3.4 l/h (0.9 gph)	3.8 l/h (1 gph)
Full Load	4.9 l/h (1.3 gph)	6.4 l/h (1.7 gph)	6.4 l/h (1.7 gph)
<b>ENGINE:</b> Kubota 4-Stroke Cycle, Indirect Injection (IDI), Water-cooled Diesel with Digital Electronic Governing			
Model	V2003	V2403	V2403

	HDKBP	HDKBR	HDKBV
Rated RPM	1500	1500	1500
Number of Cylinders	4	4	4
Bore	83 mm (3.27 in)	87 mm (3.43 in)	
Stroke	92.4 mm (3.64 in)	102.4 mm (4.03 in)	
Displacement	1,999 cm <sup>3</sup> (121.99 in <sup>3</sup> )	2,434 cm <sup>3</sup> (148.53 in <sup>3</sup> )	2,434 cm <sup>3</sup> (148.53 in <sup>3</sup> )
Compression Ratio	22.8 : 1	24.3 : 1	
Oil Capacity	7.6 liters (8.0 qt)	7.6 liters (8.0 qt)	7.6 liters (8.0 qt)
<b>Maximum Angularity any Direction:</b>			
Continuous	10°		
Intermittent	22.5°		
<b>COOLING:</b>			
Generator Set Coolant Capacity	7.3 liters (7.7 qt)	7.6 liters (8.0 qt)	
Remote Heat Exchanger Coolant Capacity	6.1 liters (6.4 qt)		
Coolant Flow Rate	46 l/min (12 gal/min)		
Heat Rejection to Coolant	360 kcal/min (1430 BTU/min)	428 kcal/min (1700 BTU/min)	464 kcal/min (1840 BTU/min)
Thermostat Opening Temperature	71 °C (159.8 °F)		
Thermostat Fully Open Temperature	85 °C (185 °F)		
Recommended Pressure Cap	48 kPa (7 psi)		
<b>GENERATOR SET AIR FLOW:</b>			
Combustion Air Flow	1.21 m <sup>3</sup> /min (42 ft <sup>3</sup> /min)	1.43 m <sup>3</sup> /min (50 ft <sup>3</sup> /min)	
Heat Rejection to Ambient	72 kcal/min (285 BTU/min)	88 kcal/min (350 BTU/min)	
<b>EXHAUST:</b>			
Maximum Exhaust Back Pressure	3 in Hg	3 in Hg	3 in Hg
Exhaust Gas Flow	4.5 m <sup>3</sup> /min (160 ft <sup>3</sup> /min)	5.1 m <sup>3</sup> /min (180 ft <sup>3</sup> /min)	
<b>DC SYSTEM:</b>			
Nominal Battery Voltage	12/24 VDC		
Minimum Battery Capacity CCA (Cold Cranking Amps)	650 Amps at 0 °C (32 °F) 12 VDC		
Battery Recharging	Installer must provide	Installer must provide	Installer must provide
<b>Net Battery Charging Output:</b>			
12 Volt Negative Ground	25 Amps		
24 Volt Negative Ground	13 Amps		

	HDKBP	HDKBR	HDKBV
<b>INSTALLATION:</b>			
Generator Set Dry Weight (with sound shield)	404 kg (890 lbs)	422 kg (930 lbs)	
Remote Heat Exchanger Dry Weight (with sound shield)	38 kg (84 lbs)		
Size (L x W x H)	1127 x 602 x 698 mm (44.4 x 23.7 x 27.5 in)	1127 x 602 x 698 mm (44.4 x 23.7 x 27.5 in)	
Sound	63 dB(A) @ 3 m (10 ft) —with sound shield at full load	63 dB(A) @ 3 m (10 ft)—with sound shield at full load	63 dB(A) @ 3 m (10 ft)—with sound shield at full load

### 3.5 List of Acronyms

TABLE 4. ACRONYM DEFINITIONS

Acronym	Definition
AC	Alternating Current
AGS	Automatic Generator Start
ANSI	American National Standards Institute
API	American Petroleum Institute
ASTM	American Society for Testing and Materials (now known as ASTM International)
BS	Build Standard
BTDC	Before Top Dead Center
CARB	California Air Resources Board
CCA	Cold Cranking Amp
CO	Carbon Monoxide
CPG	Cummins Power Generation
CSA	Canadian Standards Association
DC	Direct Current
EEPROM	Electrically Erasable Programmable Read Only Memory
EMC	Electromagnetic Compatibility
EPA	Environmental Protection Agency
GFCI	Grounded Fault Circuit Interrupters
hp	High Pressure
I.D.	Inside Diameter
ISO	International Organization for Standardization
LED	Light-emitting Diode

<b>Acronym</b>	<b>Definition</b>
NFPA	National Fire Protection Agency
NPT	National Pipe Thread
OEM	Original Equipment Manufacturer
PPE	Personal Protective Equipment
PTO	Power Take-Off
RAM	Random Access Memory
ROM	Read Only Memory
RV	Recreational Vehicle
RVIA	RV Industry Association
SAE	Society of Automotive Engineers
UNC	Unified National Coarse
US, U.S.	United States
WC	Water Column

**TABLE 5. ACRONYMS FOR UNITS OF MEASUREMENT**

<b>Acronym</b>	<b>Definition</b>
Amp	Ampere
BTU/min	British thermal unit per minute
C	Celsius
cm	centimeter
dB(A)	Decibel A-Weighted
F	Fahrenheit
ft	Feet, foot
ft-lbs	Foot-pounds
gal/min	Gallons per minute
gph	Gallons per hour
H	Height
Hz	Hertz
in	Inch
in Hg	Inch of mercury
kcal/min	kilocalories per minute
kg	kilogram
kg/h	kilograms per hour
kPa	kilopascal

<b>Acronym</b>	<b>Definition</b>
kW	kilowatt
l/h	Liters per hour
l/min	Liters per minute
L	Length
lb	Pound
lbs/h	Pounds per hour
m	Meter
ml	milliliter
mm	millimeter
Nm	Newton meter
psi	Pound per square inch
qt	Quart
RPM	Revolutions per Minute
VAC	Volts Alternating Current
VDC	Volts Direct Current
W	Watts, Width

# 4 Operation

---

## 4.1 Key Component Locations

The control panel and the components requiring attention during periodic maintenance (see [Section 5.1 on page 39](#)) are located behind a removable access cover. The figure below illustrates the components of a typical generator set. There may be some variation depending on the generator set model.

- To remove the access cover:
  1. Slide the cover latches up and pull the cover outward from the bottom.
  2. Lower the cover to remove it from the housing.
- To replace the access cover:
  1. Position the tabs on the top of the cover into the openings on the housing.
  2. Slide the latches up and push the bottom of the cover in place.
  3. Hold the cover in place firmly and release the latches.

 **WARNING**

***Operating the generator set with the access cover off can result in severe personal injury or equipment damage. Hot components are exposed when the access cover is removed and generator set cooling air does not circulate properly. Do not operate the generator set with the access cover removed.***

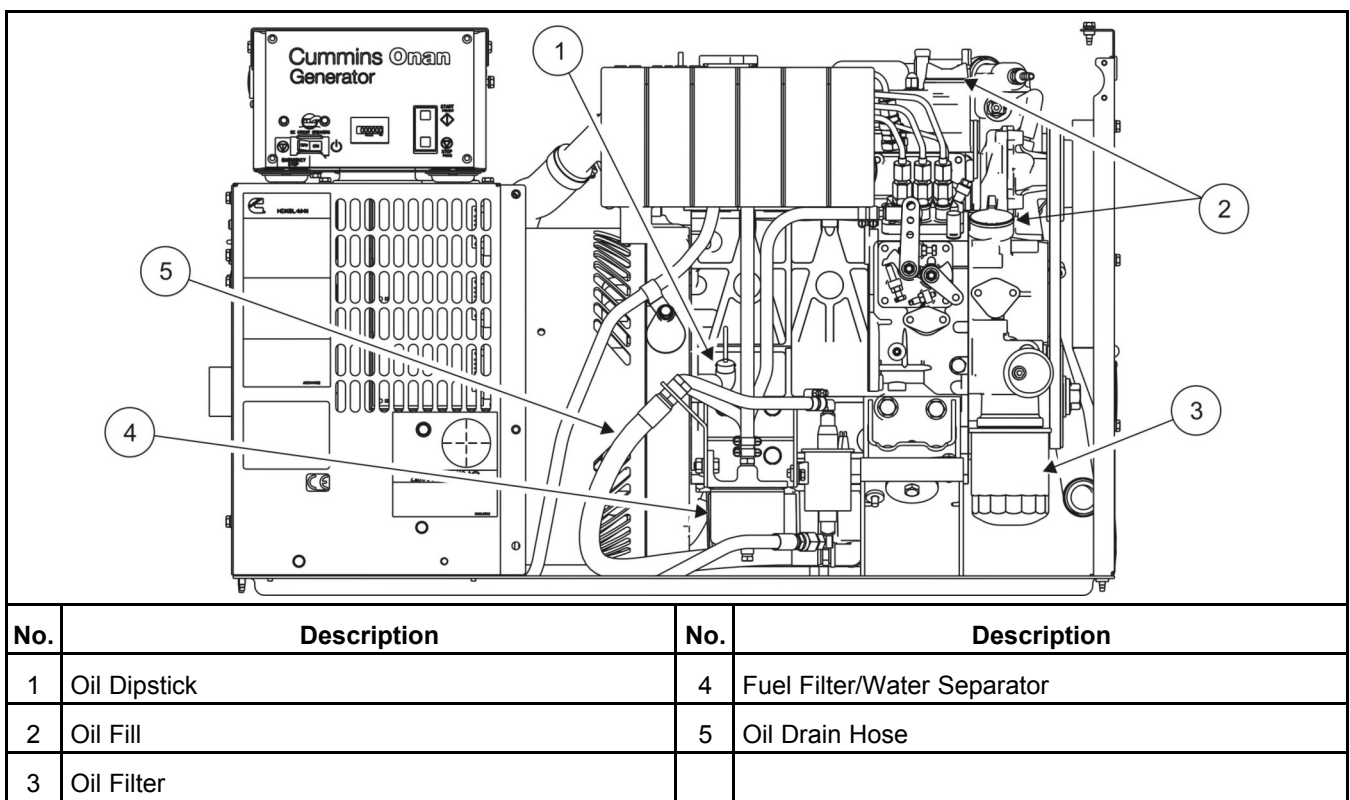

**FIGURE 2. KEY COMPONENT LOCATIONS - HDKBL**

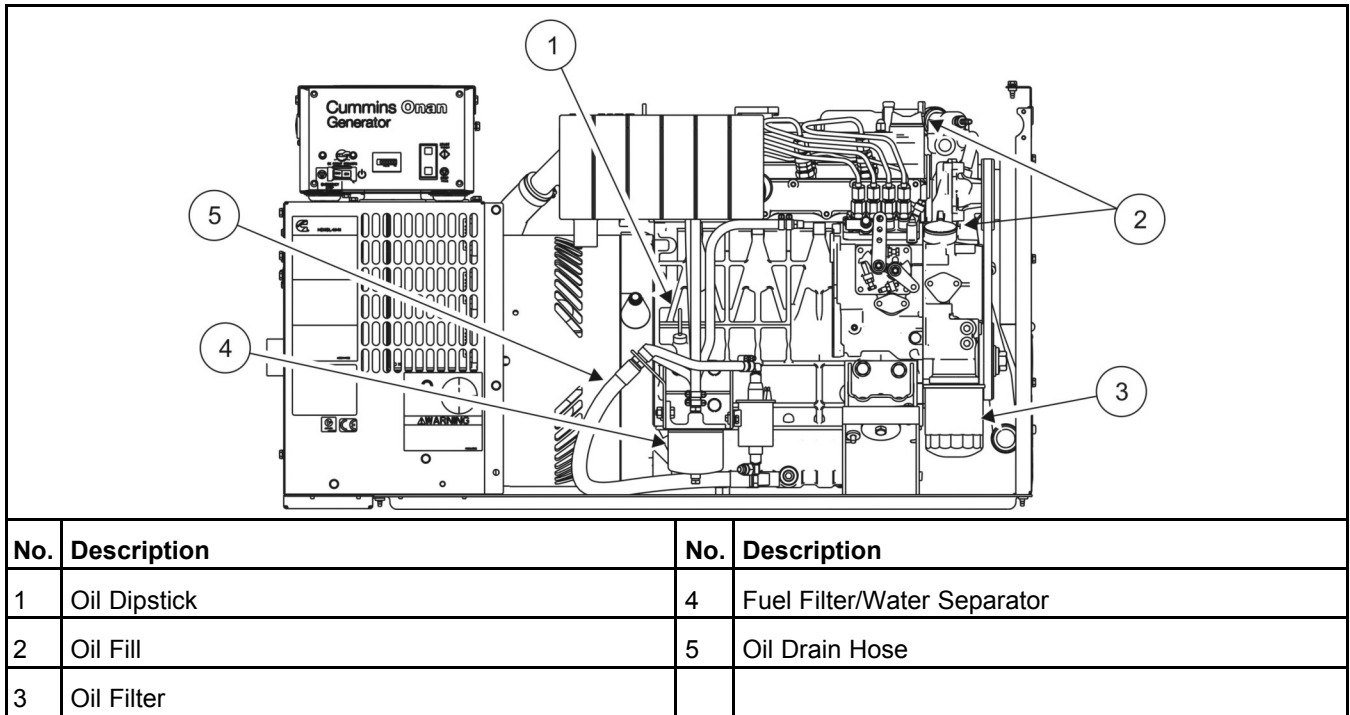

**FIGURE 3. KEY COMPONENT LOCATIONS - HDKBM, HDKBN**

**FIGURE 4. KEY COMPONENT LOCATIONS - HDKBP, HDKBR, HDKBV**



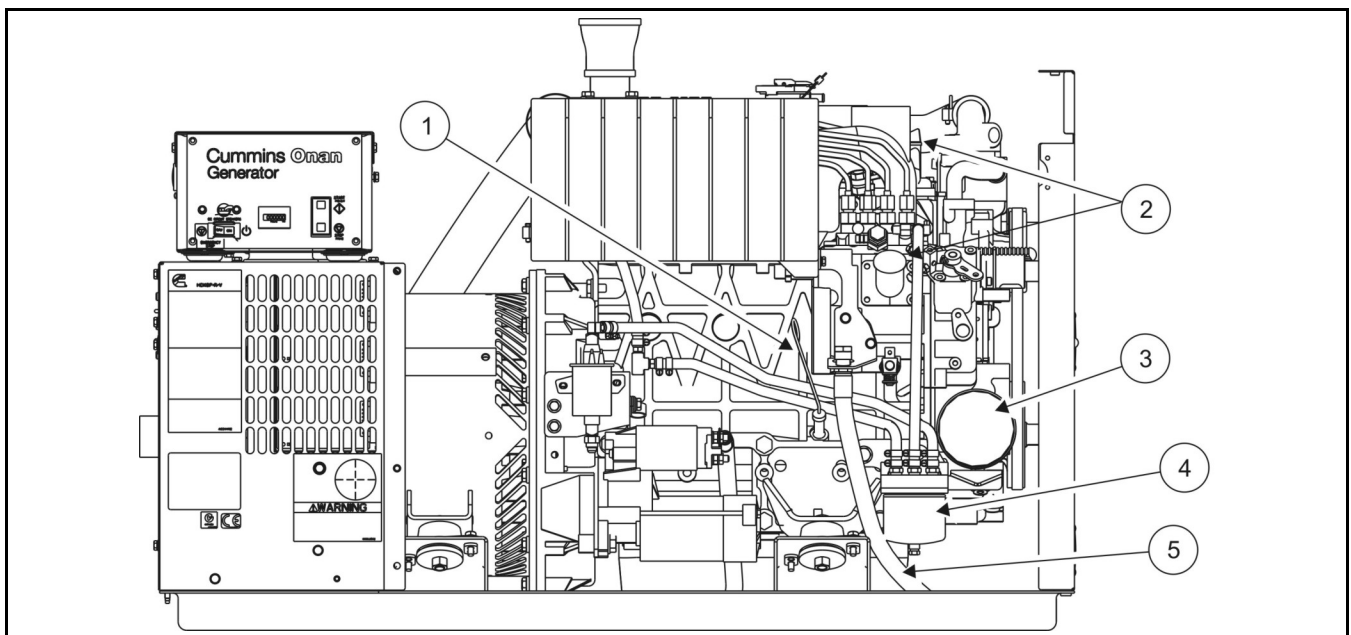

No.	Description	No.	Description
1	Oil Dipstick	4	Fuel Filter/Water Separator
2	Oil Fill	5	Oil Drain Hose
3	Oil Filter		

## 4.2 Control Panel

### 4.2.1 Generator Set Control Panel

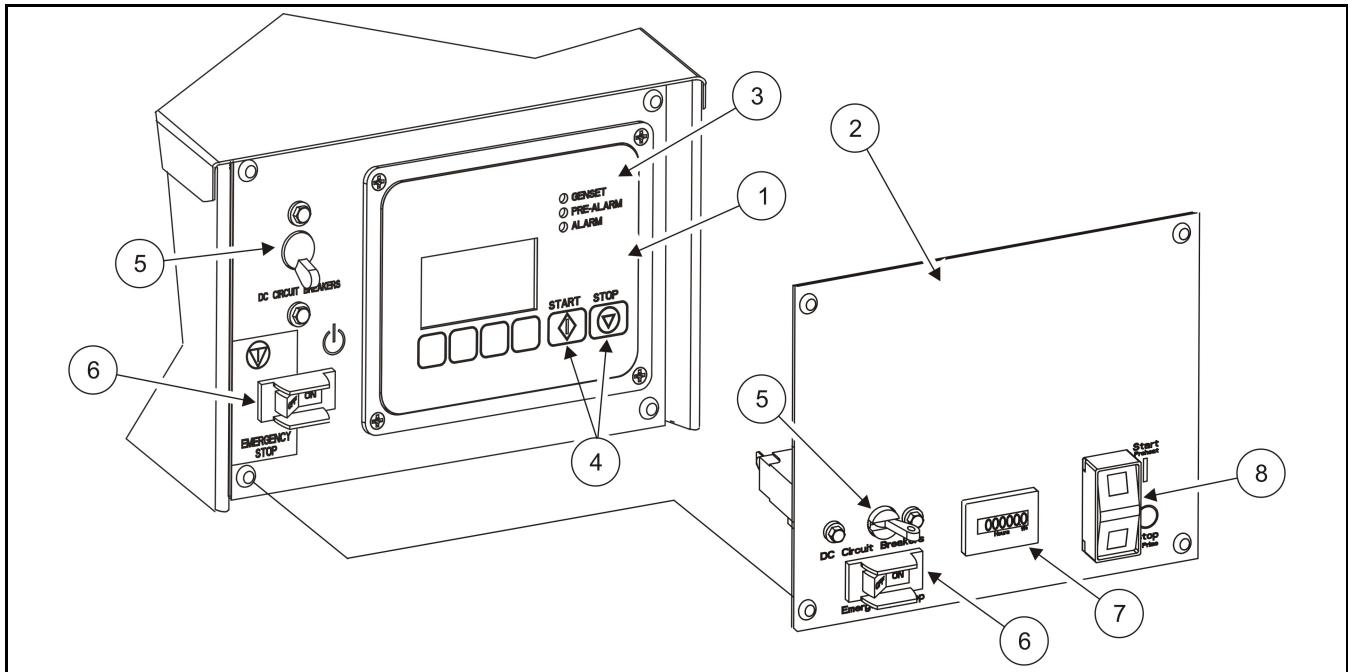

No.	Name	Description
1	Digital Display Panel (optional)	The local control panel may have a digital display panel instead of a control switch.
2	Control Switch Panel (standard)	Standard control panel used to operate generator set.
3	Status Lamps	The green <b>Genset</b> status lamp on the digital display flashes while the engine is preheating and cranking and stays on during generator set operation. The amber <b>Pre-alarm</b> status lamp lights and stays on when an engine pre-alarm condition exists. It flashes rapidly while the generator set is running in fault bypass mode, if so equipped. The red <b>Alarm</b> status lamp flashes during a fault shutdown.
4	Start and Stop Buttons	When pushed, the <b>Start</b> button starts the generator set. Status on the digital display will change from <i>Starting</i> to <i>Running</i> . When pushed, the <b>Stop</b> button shuts down the generator set. Status on the digital display will change from <i>Running</i> to <i>Stopped</i> .
5	DC Circuit Breaker	Protects the DC control circuits of the generator set from short circuits. Must be reset after repairs.
6	Emergency Stop Switch	Circuit breaker that protects the generator set control circuits from shorts to ground. In an emergency, the switch is pushed to off.
7	Hour Meter	Records the total running time of the generator set. Cannot be reset.

8	Control Switch and Status Lamps	The control switch is used to start and stop the generator set and to prime the engine fuel system. If the generator set shuts down abnormally, the amber lamp flashes a numerical code to indicate the cause of the shutdown. See <a href="#">Chapter 6 on page 65</a> for more information on fault codes and status lamp flashes.
---	---------------------------------	--------------------------------------------------------------------------------------------------------------------------------------------------------------------------------------------------------------------------------------------------------------------------------------------------------------------------------------

FIGURE 5. GENERATOR SET CONTROL PANEL

## 4.2.2 Digital Display

Touch any button to turn on the digital display panel. The main status screen (**GEN STATUS Pg1**) shows the word **Priming**, **Starting**, **Running**, **Stopped**, **Volt Adj**, or **Fault Override** depending on the operating status of the generator set.

Use the double arrows to navigate through the screens, or touch any one of the **SETUP**, **FAULT**, or **SCREEN** buttons for more options.

Additional status screen information includes:

- AC output voltage
- AC frequency
- engine coolant temperature
- engine oil pressure
- starting battery voltage
- total hours of generator set running time.

A fourth screen, if so equipped, shows:

- percentage of full load in 10% increments as a bar graph
- engine RPM
- engine air intake manifold temperature
- fuel temperature
- fuel rate of consumption.

### NOTICE

The total time on the master hour meter prevails if the total time on the digital display is different. See the Service Manual for more information on resetting the hour meter.

### 4.2.2.1 Generator Set Status Screens

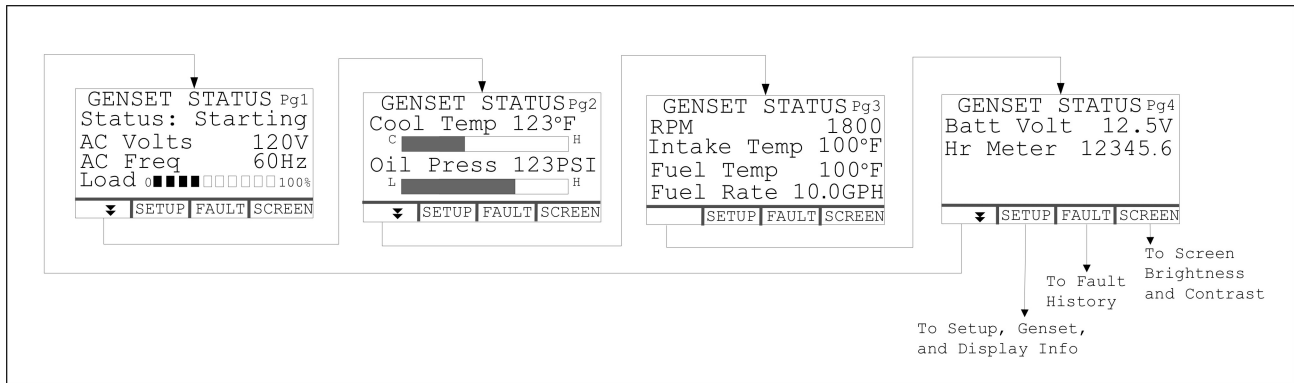

FIGURE 6. GENERATOR SET STATUS SCREENS

### 4.2.2.2 Fault Screen

If a fault shutdown occurs, the alarm status lamp will blink, and the screen will display a description of the fault, the numeric fault code, and the hour the fault occurred in total generator set running time (see figure below). Refer to [Chapter 6 on page 65](#) to diagnose and correct the problem.

The screen will display the fault indefinitely until any button is touched to clear the fault. The digital display will turn off in 5 minutes after the fault has been cleared.

Press **BACK** to return to **GEN STATUS**.

FIGURE 7. DIGITAL DISPLAY FAULT SCREEN

### 4.2.2.3 Fault History

To display any of the last five faults, press **FAULT** on any **GEN STATUS** screen and **HIST** on the **FAULT** screen.

The **FAULT HISTORY** screen displays a description of the fault, the numeric fault code, and the hour the fault occurred in total generator set running time. Press the double arrows to toggle between the last 5 faults. If there are no faults, the **FAULT HISTORY** screen displays **No Stored Faults**.

Press **BACK** to return to **GEN STATUS**.

FIGURE 8. FAULT HISTORY

### 4.2.2.4 Engine Pre-Alarms

The **PRE-ALARM** status lamp will blink when the engine oil pressure or engine temperature approaches its engine shutdown limit. The screen will display **Low Oil Pressure** or **High Engine Temperature** (see figure below).

Pre-Alarm set-points are as follows: Low Oil Pressure is less than or equal to 138 kPa (20 PSI) for 3 consecutive seconds. and High Engine Temperature is greater than 212°F (100°C) for 3 consecutive seconds.

Press **BACK** to return to **GEN STATUS** in order to monitor engine temperature and oil pressure. Service the generator set as required.

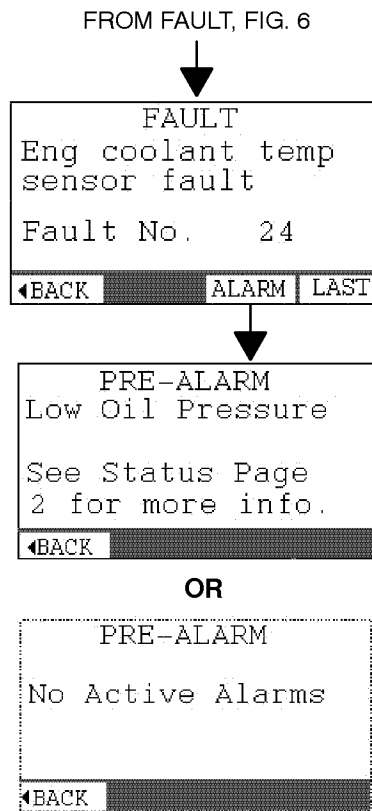

**FIGURE 9. ENGINE PRE-ALARMS**

### 4.2.2.5 Brightness and Contrast

To adjust the brightness or contrast of the digital display screen, press **SCREEN** on any **GEN STATUS** screen, then **NEXT** to toggle between Brightness and Contrast. Press the right or left arrow to increase or decrease brightness or contrast.

Press **BACK** to save the settings and return to **GEN STATUS**.

**NOTICE**

**These settings apply only to the control panel that the change was made on, not to any remote panels. Any other panels need to be changed locally.**

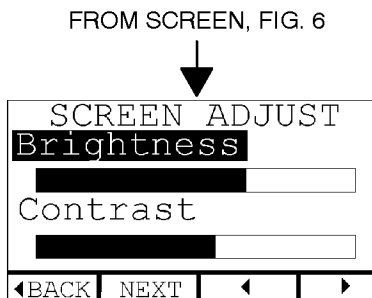

**FIGURE 10. SCREEN BRIGHTNESS AND CONTRAST**

### 4.2.2.6 Display Setup

**⚠ WARNING****AC Output Voltage**

*Troubleshooting procedures or replacement of parts present hazards that can result in equipment damage and severe personal injury or death.*

*Have a trained and experienced person adjust AC output voltage, if necessary, before calibrating the digital display voltmeter.*

The **SETUP** screen allows for setting units of measure and voltmeter calibration, and gives general information about the generator and display ([Figure 11 on page 29](#)). Press **SETUP** on any **GEN STATUS** screen then the up or down arrow to toggle through the options: **DISPLAY SETUP**, **GENSET INFO**, or **DISPLAY INFO**. Press **ENTER** when the desired option is highlighted.

To select the units of measure for the **GEN STATUS** screens, press **NEXT** on the **DISPLAY SETUP** screen to highlight **UNITS** and then the up or down arrow to select **SAE** or **METRIC**. Press **BACK** to save the selection and return to **GEN STATUS**.

To calibrate the digital display voltmeter, press **NEXT** on the **DISPLAY SETUP** screen to highlight **AC Voltmeter Calibration** and then press the up or down arrow to increase or decrease the voltage displayed so that it matches that of an accurate AC voltmeter (line-to-line or line-to-neutral, as desired). Press **BACK** to save the selection and return to **GEN STATUS**.

**NOTICE**

**This procedure does not change AC output voltage.**

### 4.2.2.7 Generator Set and Digital Display Information

Press **SETUP** on any **GEN STATUS** screen. Press the up or down arrow on the **SETUP** screen to select **GENSET INFO** or **DISPLAY INFO** and press **ENTER**. This information may be requested by the service technician. Keep pressing **BACK** to get back to **GEN STATUS**.

**GENSET INFO** and **DISPLAY INFO** screens show software part numbers and version detail information that may be requested by a service technician. Press **BACK** to return to **GEN STATUS**.

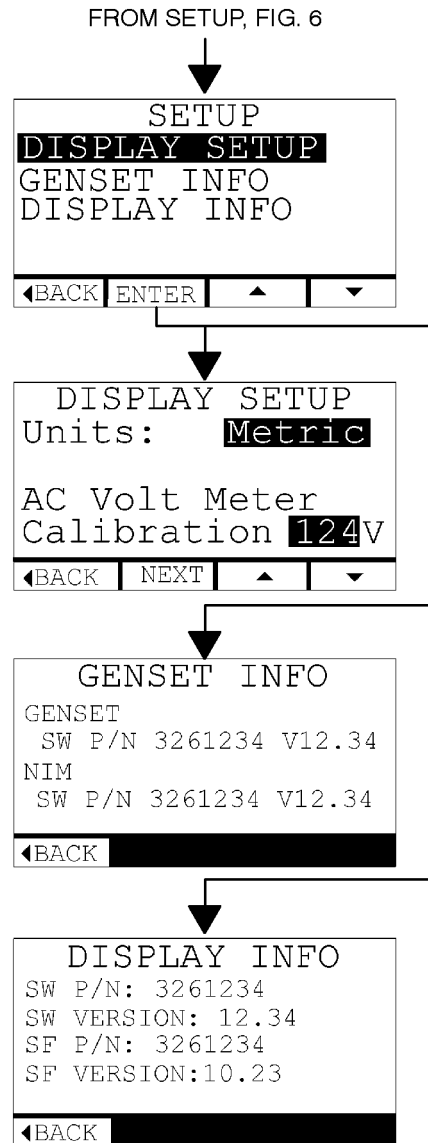

FIGURE 11. DISPLAY SETUP, GENSET INFO, DISPLAY INFO

### 4.2.3 Remote Control Panel

A remote control panel may be installed inside the vehicle. There are 3 remote control panel kits available.

- Control switch with status indicator.
- Control switch with status indicator and an hour meter.
- Control switch with status indicator and a DC voltmeter.

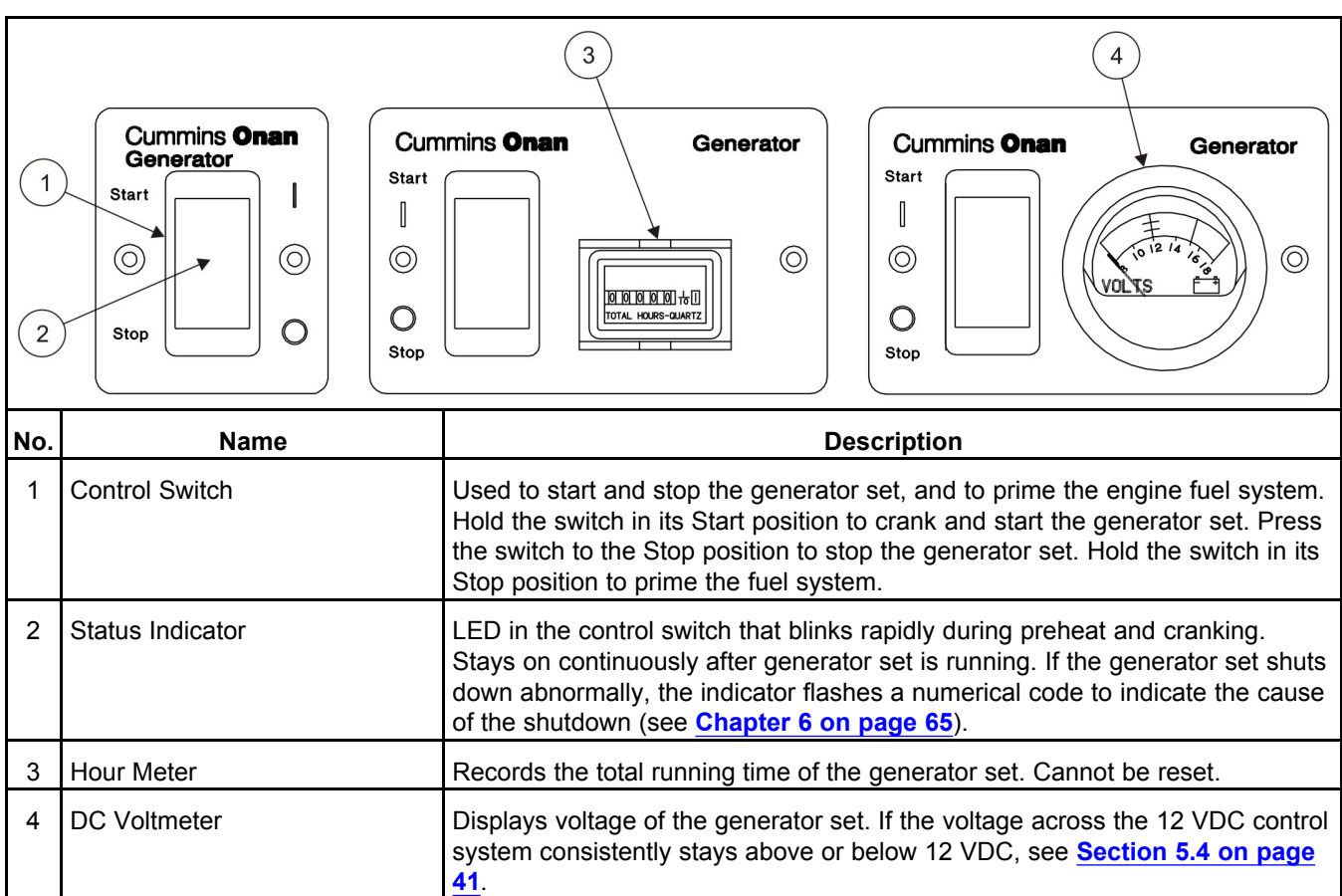

FIGURE 12. REMOTE CONTROL PANELS



## 4.3 Starting and Stopping the Generator Set

### 4.3.1 Pre-start Checks

#### WARNING

##### ***EXHAUST GAS IS DEADLY!***

***Exhaust gases contain carbon monoxide, an odorless, colorless gas. Carbon monoxide is poisonous and can cause unconsciousness and death. Symptoms of carbon monoxide poisoning include:***

- ***Dizziness***
- ***Muscular twitching***
- ***Weakness and sleepiness***
- ***Throbbing in temples***
- ***Headache***
- ***Inability to think clearly***
- ***Nausea***
- ***Vomiting***

***IF YOU OR ANYONE ELSE EXPERIENCES ANY OF THESE SYMPTOMS, GET OUT INTO THE FRESH AIR IMMEDIATELY. If symptoms persist, seek medical attention. Shut down the generator set and do not operate it until it has been inspected and repaired.***

***Never occupy the vehicle with the generator set running unless the vehicle is equipped with a working carbon monoxide detector. However, primary protection against inhaling carbon monoxide is proper installation of the exhaust system, and daily (every 8 hours) inspection for visible and audible exhaust system leaks.***

Perform pre-start checks before the first start of the day and after every 8 hours of operation. See [Chapter 5 on page 39](#) if the vehicle has been in storage.

1. Make sure all vehicle CO detectors are working properly.
2. Remove access cover.
3. Inspect the generator set as instructed in [Chapter 5 on page 39](#).
4. Perform any maintenance due ([Section 5.1 on page 39](#)).
5. Keep a maintenance log ([Chapter 7](#)).
6. Check for signs of fuel and exhaust leaks and for damage to the exhaust system.
7. Replace access cover.
8. Turn off the air conditioner and other large appliances.

### 4.3.2 Priming the Fuel System

The fuel system should be primed after the fuel filter is replaced or after the generator set runs out of fuel.

Position the control switch to **STOP/PRIME** for 30 seconds. The status indicator stays on while the pump is on.

### 4.3.3 Starting the Generator Set

The generator set can be started and stopped from the generator set control panel or remote control panel.

1. Visually check for water, coolant, fuel, and exhaust leaks. Stop the generator set immediately if there is a leak. Repair fuel leaks immediately.
2. Push and hold start on the control switch or digital display until the generator set starts. The generator set status lamp blinks when the engine is cranking and comes on and stays on when the generator set starts and runs. Status on the digital display changes from **Starting** to **Running**.
3. For longer engine life, let the engine warm up for two minutes before connecting air conditioners and other large electrical load.
4. Monitor the generator set status using the digital display. Perform maintenance or service as necessary if the display indicates a pre-alarm condition ([Chapter 5](#)).
5. If the generator set fails to start, cranking will discontinue in 20 to 60 seconds, depending on engine temperature. The digital display and/or control switch status lamp will indicate Fault Code No. 4. See [Chapter 6](#) if the generator set does not start after several tries.

#### CAUTION

**Excessive cranking can burn out the starter or flood the engine. Find out why the generator set does not start and make necessary repairs.**

6. If the generator set shuts down, the digital display and/or control switch status lamp will indicate the numeric fault code. See [Chapter 6](#).

### 4.3.4 Stopping the Generator Set

1. Turn off the air conditioner and other large appliances.
2. Run generator set for 2 minutes to allow for cool down.
3. Press the control switch in its **STOP** position.

## 4.4 Loading the Generator Set

The power rating (kW) on the generator set nameplate determines how much electrical load (motors, fans, heaters, air conditioners, and other appliances) the generator set can power. If the sum of the loads exceeds the generator set power rating, the generator set will shut down or its line circuit breakers will trip.

#### NOTICE

**It may be necessary to run fewer appliances at the same time—the sum of the loads must not be greater than the generator set power rating.**

To avoid shutdowns due to generator set overload, use the electrical ratings on the nameplates of equipment (if available) to compare the sum of the electrical loads that are likely to be used at the same time to the generator set power rating. Refer to the table below for typical appliance ratings.

Appliance load and generator set power are measured in terms of Watts (W) or kilowatts (kW), where 1 kilowatt (kW) = 1000 Watts (W).

- If the equipment is marked in Amps and Volts only, multiply the Amps times the Volts to obtain the load in Watts.
- Divide Watts by 1000 to obtain load in terms of kilowatts.

It is possible that the generator set circuit breaker may trip even though the sum of the steady state loads is less than the generator set power rating. When a large motor or air conditioner is started last or cycles off and on, the startup load is larger than its normal running load, causing the load to temporarily exceed the generator set power rating.

Typical "invisible" charging loads:

- During startup, air conditioners need "reserve" power and can draw 3–4 times the typical 1400–2400 Watts needed to run. Too much baseload can prevent air conditioners from starting.
- Battery chargers are activated automatically and can draw a large load (up to 3000 Watts). Manage electrical loads by adjusting battery charge rates to best suit your needs. Consult your inverter/charger manual or manufacturer.

**TABLE 6. TYPICAL APPLIANCE LOADS**

<b>Appliance</b>	<b>Average Required Wattage</b>	<b>Amps</b>
Air Compressor (1hp)	900-1800	7.5-15
Air Conditioner	1200-2400	10-20
Battery Charger <sup>1</sup>	Up to 3000	6-28
Blender	450-700	3.3-5.8
Broiler	1400-1700	11.6-14
Broom/Vacuum	1000-1440	8.3-12
CD/mp3 Player & Speakers	85	0.7
Coffeepot	900-1200	7.5-10
Computer	60-270	0.5-2.25
Laptop	20-50	0.16-0.41
Converter	500-1000	4-8
Curling Iron	20-50	0.16-0.41
Dishwasher	1200-2400	10-20
Drill	250-1000	2-8
Electric Blanket	60-100	0.5-0.8
Fan	10-175	0.08-1.45
Flat Iron	40-80	0.3-0.6
Frying Pan/Wok	1000-1350	8-11.25
Game Console	19-200	0.16-1.6
Hair Dryer	1200-1875	10-15.6
Iron	1000-1800	8-15
Light Bulbs	13-100	0.1-0.8
Microwave/Convection Oven	750-1100	6.25-9.2
Radio	50-200	0.4-1.6
Refrigerator	400-1000	3.3-8

Appliance	Average Required Wattage	Amps
Shaver	15-20	0.12-0.16
Space Heater	750-1500	6.25-12.5
Stove	900-2500	7.5-20.8
Television	43-600	0.35-5
Toaster	800-1400	6.6-11.6
VCR/DVD/Blu-ray Player	6-30	0.05-0.25
Washer/Dryer	350-500/1800-5000	3-4/15-42
Water Heater	1000-1500	8-12.5
Water Pump	250-1100	2-9.16

<sup>1</sup> Battery chargers can be a source of significant load and will be on whether they are connected to shore power or the generator set.

### 4.4.1 Power Versus Altitude

The generator set is rated at standard barometric pressure, humidity, and air temperature (reference ISO 3046). Low barometric pressure (high altitude) or high ambient temperature decreases engine power.

- As ambient temperature increases, rated generator set engine power decreases approximately 1% for every 5.5 °C (10 °F) above 29 °C (85 °F).
- Power decreases approximately 3.5% of rated power each 305 m (1000 ft) of increase in elevation. Refer to the tables below for typical elevation/generator set power calculations.

**NOTICE**

**It may be necessary to run fewer appliances at higher altitudes and ambient temperatures.**

**TABLE 7. POWER VERSUS ALTITUDE - HDKBL, HDKBM, HDKBN**

Elevation Above Mean Sea Level	HDKBL Maximum Generator Set Power <sup>1</sup>	HDKBM Maximum Generator Set Power <sup>1</sup>	HDKBN Maximum Generator Set Power <sup>1</sup>
Up to 152 m (500 ft)	7000 Watts (rated)	9500 Watts (rated)	11,000 Watts
762 m (2500 ft)	6510 Watts	8835 Watts	10,230 Watts
1676 m (5500 ft)	5775 Watts	7837 Watts	9,075 Watts
Above 1676m (5500 ft)	5775 Watts minus 245 Watts each 305 m (1000 ft)	7837 Watts minus 333 Watts each 305 m (1000 ft)	9,075 Watts minus 385 Watts each 305 m (1000 ft)

<sup>1</sup>. Does not take into account the effect circuit breakers may have in limiting maximum power.

**TABLE 8. POWER VERSUS ALTITUDE - HDKBP, HDKBR, HDKBV**

Elevation Above Mean Sea Level	HDKBP Maximum Generator Set Power <sup>1</sup>	HDKBR Maximum Generator Set Power <sup>1</sup>	HDKBV Maximum Generator Set Power <sup>1</sup>
--------------------------------	------------------------------------------------	------------------------------------------------	------------------------------------------------

Up to 152 m (500 ft)	13,500 Watts (rated)	17,500 Watts (rated)	19,000 Watts (rated)
762 m (2500 ft)	12,555 Watts	16,275 Watts	17,670 Watts
1676 m (5500 ft)	11,137 Watts	14,437 Watts	15,675 Watts
Above 1676 m (5500 ft)	11,137 Watts minus 473 Watts each 305 m (1000 ft)	14,437 Watts minus 613 Watts each 305 m (1000 ft)	15,675 Watts minus 665 Watts each 305 m (1000 ft)
1. Does not take into account the effect circuit breakers may have in limiting maximum power.			

## 4.5 Exercising the Generator Set

Exercise the generator set at least 2 hours each month if use is infrequent. Run the generator set at approximately 1/2 rated power. A single 2-hour exercise period is better than several shorter periods.

Exercising a generator set drives off moisture, relubricates the engine, replaces stale fuel in fuel lines, and removes oxides from electrical contacts and generator slip rings. The result is better starting, longer engine life, and greater reliability.

## 4.6 Resetting Line Circuit Breakers

If a generator set line circuit breaker or a circuit breaker in the power distribution panel trips, either a short circuit has occurred or too many loads were connected.

### NOTICE

**The generator set continues to run if its circuit breaker trips.**

If a circuit breaker trips:

1. Disconnect or turn off as many electrical loads as possible.
2. Reset the circuit breaker.
3. If the circuit breaker trips right away, either the appliance (or electrical load) has a short or the circuit breaker is faulty. Call a qualified electrician.

### NOTICE

**It may be necessary to push the circuit breaker OFF to reset it and ON to reconnect the circuit.**

4. If the circuit breaker does not trip right away, reconnect loads one-by-one making sure not to overload the generator set or cause a circuit breaker to trip. If a circuit breaker trips right away when an appliance is connected, that appliance or circuit probably has a short.

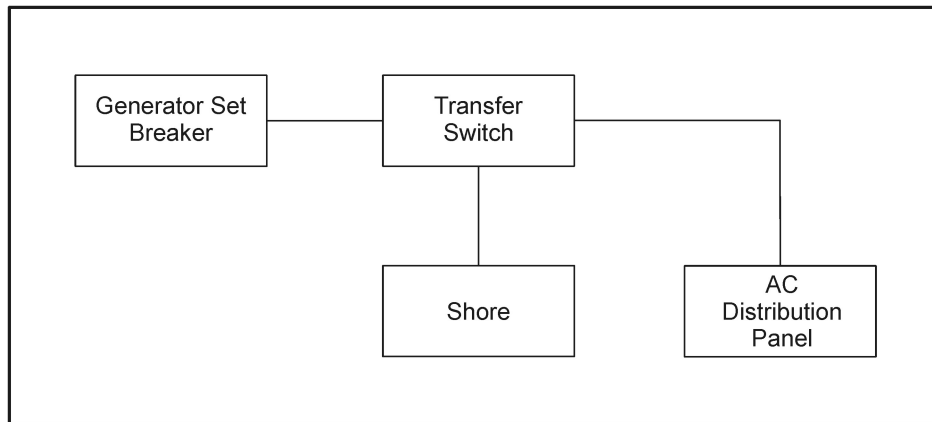

FIGURE 13. CIRCUIT BREAKER CONNECTIONS

**⚠ WARNING**

*Short circuits in electrical equipment can cause fire and electrical shock leading to severe personal injury or death. Electrical equipment and its grounding must be maintained properly to protect against short circuits.*

Electrical equipment must be used and maintained properly, and be properly grounded, to cause the line circuit breakers to trip when short circuits occur.

Electrical appliances and tools must be used and maintained in accordance with their manufacturer's instructions and safety precautions. Proper grounding is needed to reduce the risk of electric shock and fire.

## 4.7 Connecting Shore Power

**⚠ WARNING**

*Interconnecting the generator set and shore power can lead to electrocution of utility line workers, equipment damage, and fire. Use an approved switching device to prevent interconnections.*

A vehicle with provisions for connecting utility power must have an approved device to keep the generator set and utility from being interconnected. See the generator set Installation Manual for more information.

## 4.8 Operating in Weather Extremes

Pay particular attention to the following items when operating the generator set in cold or hot weather.

1. Make sure nothing blocks airflow to and from the generator set.
2. Make sure engine oil viscosity is appropriate for the ambient temperature. See [Section 5.5 on page 41](#) for engine oil recommendations.
3. Keep the generator set clean.
4. Perform maintenance due. See [Section 5.1 on page 39](#).

## 4.9 Operating in Dusty Environments

Pay particular attention to the following items when operating the generator set in dusty environments.

1. Do not let dirt and debris accumulate inside the generator set compartment. Keep the generator set clean.
2. Perform air filter element maintenance more often.
3. Change engine oil more often.

## 4.10 Care of New or Rebuilt Engine

Proper engine break-in on a new generator set or on one with a rebuilt engine is essential for top engine performance and acceptable oil consumption. Run the generator set at approximately 1/2 rated power for the first 2 hours and at 3/4 rated power for 2 more hours.

Proper engine oil and oil level are especially critical during break-in because of the higher engine temperatures that can be expected. Change the oil if the oil is not appropriate for the ambient temperatures during break-in. See [Section 5.5 on page 41](#) for engine oil recommendations.

Check oil level twice a day or every 4 hours during the first 50 hours of operation and change the oil and oil filter after the first 50 hours of operation.

This page is intentionally blank.



# 5 Maintenance

**⚠ WARNING**

*Only authorized and competent personnel who are familiar with the equipment and its operation should carry out maintenance.*

## 5.1 Periodic Maintenance

**⚠ WARNING**

*Accidental starting can cause severe personal injury or death. Turn off the AGS whenever performing maintenance or service, when the vehicle is stored between uses, is awaiting service, or is parked in a garage or other confined area.*

Periodic maintenance is essential for top performance and long generator set life. Use the Periodic Maintenance Schedule below for normal periodic maintenance. In hot and dusty environments some maintenance procedures should be performed more frequently, as indicated by the footnotes in the schedule. Keeping a log of maintenance performed and hours run will help keep generator set maintenance regular and provide a basis for supporting warranty claims (see [Chapter 7](#)).

Maintenance, replacement, or repair of emission control devices and systems may be performed by any engine repair establishment or individual. However, warranty work must be completed by an authorized Cummins Service Representative.

### 5.1.1 Periodic Maintenance Schedule

TABLE 9. PERIODIC MAINTENANCE SCHEDULE

MAINTENANCE PROCEDURE	MAINTENANCE FREQUENCY								
	After First 50 Hours	Every Day/ 8 Hours	Every Month / 100 hours	Every Year / 200 Hours	Every Year / 350 Hours	Every Year / 500 Hours	Every 800 Hours	Every 2 Years	Every 5 Years / 2000 Hours
General Inspection <sup>1</sup>		X							
Check Engine Oil Level		X							
Drain Water From Fuel Filter, if equipped			X						
Check Battery and Battery Connections <sup>2</sup>			X						
Check V-Belt Tension <sup>3</sup>			X						
Change Oil and Oil Filter <sup>5</sup>	X			X					
Change Air Filter						X			
Change Fuel Filter						X			
Clean Fan Motor Body of Dust/Dirt						X			
Clean Fan Impeller Blades of Dust/Dirt						X			

MAINTENANCE PROCEDURE	MAINTENANCE FREQUENCY								
	After First 50 Hours	Every Day/ 8 Hours	Every Month / 100 hours	Every Year / 200 Hours	Every Year / 350 Hours	Every Year / 500 Hours	Every 800 Hours	Every 2 Years	Every 5 Years / 2000 Hours
Clean Heat Exchanger Core of Dust/Dirt						X			
Adjust Valve Lash							X		
Replace Coolant, Pressure Cap, and Thermostat								X	
Inspect Generator Bearing <sup>4</sup>									X
<p>1 - Includes inspection of battery connections, oil level, fuel system, coolant level, exhaust system.</p> <p>2 - See battery manufacturer's recommendations.</p> <p>3 - Check for slippage, cracking, and wear.</p> <p>4 - Must be performed by a qualified mechanic (authorized Cummins Onan Service Representative).</p> <p>5 - Perform twice as often when using high sulfur fuel. See <a href="#">Section 5.5.2 on page 42</a>.</p>									

## 5.2 Consumable Parts

The following is a list of consumables associated with the generator models covered in this manual:

**TABLE 10. CONSUMABLE PARTS**

Part Number	Description	Quantity
185-5835	Oil Filter	1
185-6934	Belt, Fan (37.5 inches)	1
A026K278	Fuel Filter	1
185-6005	Thermostat	1
185-6004	Gasket, Thermostat	1
A026L076	Air Filter	1

## 5.3 General Inspection

1. Check battery connections ([Section 5.4 on page 41](#)).
2. Check engine oil level ([Section 5.5 on page 41](#)).
3. Check engine coolant level ([Section 5.7 on page 51](#)).
4. Check fuel system ([Section 5.6 on page 46](#)).
5. Check exhaust system ([Section 5.8 on page 62](#)).
6. Check mechanical system ([Section 5.9 on page 63](#)).

## 5.4 Maintaining the Battery

The generator set requires a 12 Volt battery to power its control and starting circuits. Reliable generator set starting and starter service life depend upon adequate battery system capacity and maintenance.

### WARNING

#### ***Fire Hazard***

***Flames, sparks, or arcing at battery terminals, light switches, or other equipment can ignite battery gas, causing severe personal injury.***

***Ventilate the battery area before working on or near a battery, wear safety glasses, and do not smoke. Turn work light on or off away from the battery.***

Refer to [Section 5.1 on page 39](#) for the battery maintenance schedule and follow the battery manufacturer's instructions. Have the battery charging system serviced if DC system voltage is consistently low or high.

Check the battery terminals for clean, tight connections. Loose or corroded connections have high electrical resistance which makes starting harder.

1. Keep the battery case and terminals clean and dry.
2. Keep the battery terminals tight.
3. Remove battery cables with a battery terminal puller.
4. Make sure which terminal is positive (+) and which is negative (–) before making battery connections, always removing the negative (–) cable first and reconnecting it last to reduce arcing.

## 5.5 Maintaining the Lubrication System

Keep dirt, water, and other contaminants from entering the lubrication system and corroding or clogging lubrication components.

### 5.5.1 Oil Level

Park the vehicle on level ground and stop the generator set before checking engine oil level.

### WARNING

#### ***Hot Surfaces***

***Contact with hot surfaces can cause severe burns, lacerations and liquid splash.***

***Wear appropriate PPE when working on hot equipment and avoid contact with hot surfaces.***

### WARNING

#### ***Crankcase Pressure***

***Crankcase pressure can blow hot engine oil out the fill opening causing, severe burns.***

***Always stop the generator set before removing the oil fill cap.***

**⚠ WARNING****Toxic Hazard**

**State and federal agencies have determined that contact with used engine oil can cause cancer or reproductive toxicity.**

**Avoid skin contact and breathing of vapors. Use rubber gloves and wash exposed skin.**

**NOTICE**

**Too little oil can cause severe engine damage. Too much oil can cause high oil consumption. Keep the oil level between the high and low beads (or markings) on the dipstick.**

1. Pull out the dipstick.
2. Wipe off the dipstick and reinsert it.
3. Pull it out again to check oil level.
4. Add or drain oil as necessary. Keep the oil level between the full and add marks.
5. Insert the dipstick and secure the oil fill cap.

## 5.5.2 Engine Oil Recommendations

Use API (American Petroleum Institute) classified engine oils according to the following guidelines.

- In emissions regulated areas, it is mandatory to use CF, CF-4, CG-4, CH-4, or CI-4 class oil with:
  - Low sulfur fuel - sulfur content less than 500 ppm (0.05% weight).
  - Ultra low sulfur fuel - sulfur content less than 15 ppm ( 0.0015% weight).
- In non-emissions regulated areas, use high sulfur fuel.
  - If sulfur content is between 500 ppm (0.05% weight) and 5000 ppm (0.5% weight), CF class oil is recommended.
  - If sulfur content is between 5000 ppm (0.5% weight) and 10,000 ppm (1.0% weight), use CF, CF-4, CG-4, CH-4, or CI-4 class oil.

**NOTICE**

**If high sulfur fuel is used, the oil and oil filter must be changed twice as often.**

Look for the SAE (Society of Automotive Engineers) viscosity grade. Choose the viscosity grade appropriate for the ambient temperatures expected until the next scheduled oil change. Multigrade oils such as SAE 15W-40 are recommended for year round use.

**TABLE 11. OIL VISCOSITY VS. TEMPERATURE**

EXPECTED AMBIENT TEMPERATURES	SAE VISCOSITY GRADE
0 °C (32 °F) and higher	30
-12 to 38 °C (10 to 100 °F)	15W-40 (OnaMax)
-18 to 27 °C (0 to 80 °F)	10W-30 10W-40
-28 to 10 °C (-20 to 50 °F)	5W-30

### 5.5.3 Changing Engine Oil and Oil Filter

#### WARNING

##### *Accidental or Remote Starting*

*Accidental or remote starting can cause severe personal injury or death.*

*Before removing a panel or access door, or before working on the generator set, use an insulated wrench to disconnect the negative (-) cable from the battery to prevent accidental starting.*

#### WARNING

##### *Hot Surfaces*

*Contact with hot surfaces can cause severe burns, lacerations and liquid splash.*

*Wear appropriate PPE when working on hot equipment and avoid contact with hot surfaces.*

#### WARNING

##### *Toxic Hazard*

*State and federal agencies have determined that contact with used engine oil can cause cancer or reproductive toxicity.*

*Avoid skin contact and breathing of vapors. Use rubber gloves and wash exposed skin.*

Refer to [Section 5.1 on page 39](#) for the engine oil change schedule. Change oil more often in hot or dusty environments.

1. Run the generator set under load until it is up to operating temperature, stop it, and disconnect the negative (-) battery cable at the battery.

#### WARNING

##### *Crankcase Pressure*

*Crankcase pressure can blow hot engine oil out the fill opening causing, severe burns.*

*Always stop the generator set before removing the oil fill cap.*

2. Remove the oil fill plug.
3. Place a pan underneath the oil drain hole and open the drain valve. Let all oil drain from the engine.
4. Close the drain valve.
5. Spin off the oil filter and thoroughly wipe off the filter mounting surface. Remove the gasket if it does not come off with the filter.
6. Apply a film of oil to the new filter gasket and spin the new filter on by hand until the gasket just touches the mounting pad. Tighten 1/2 to 3/4 of a turn.

#### NOTICE

**Too little oil can cause severe engine damage. Too much oil can cause high oil consumption. Keep the oil level between the high and low beads (or markings) on the dipstick.**

7. Refill with 4 liters (4.2 qts) of oil. Check the oil level and add or drain oil as necessary.
8. Screw the oil fill cap on securely.

9. Reconnect the negative battery cable.
10. Run the generator for a few minutes, shut it down, and recheck for proper oil level and leaks.
11. Dispose of the used oil and oil filter in accordance with local environmental regulations.

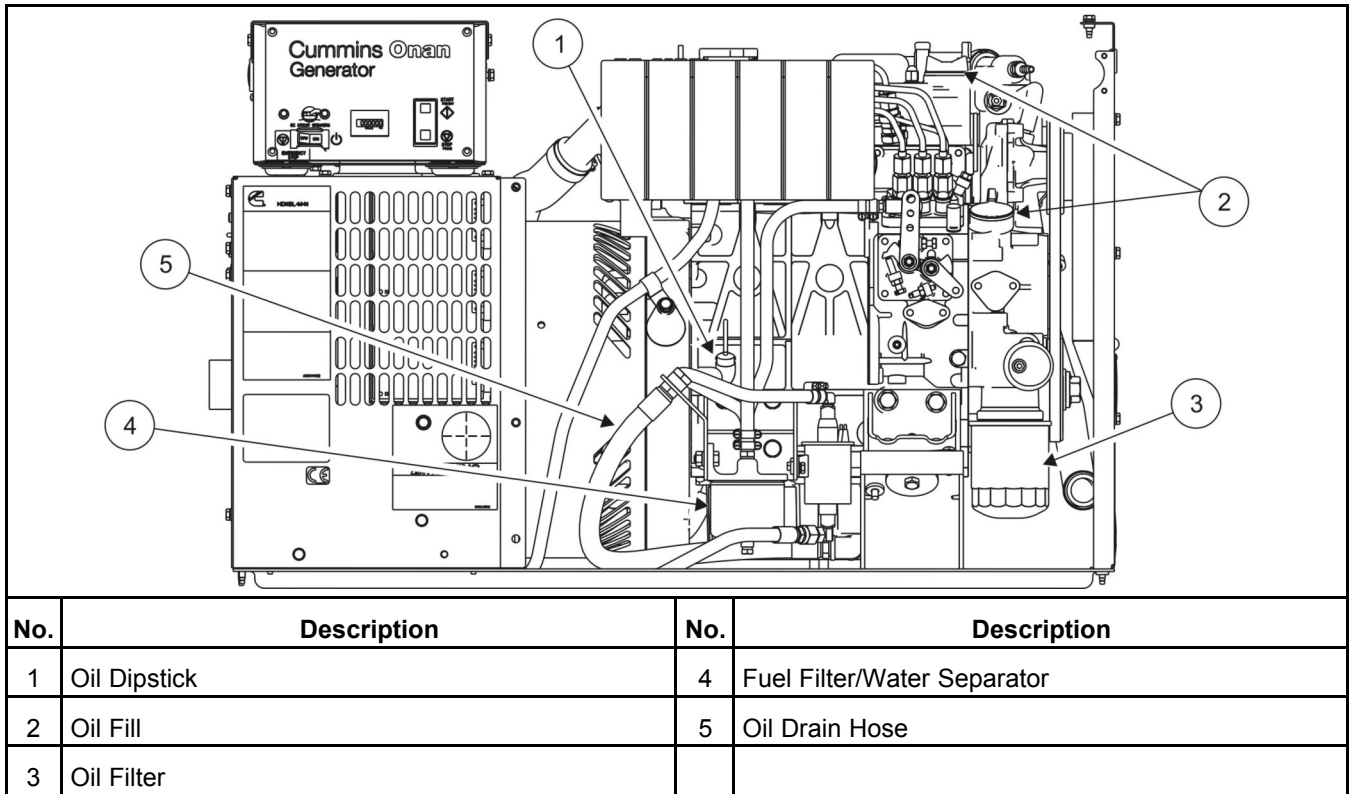

**FIGURE 14. SERVICE POINT LOCATIONS - HDKBL**

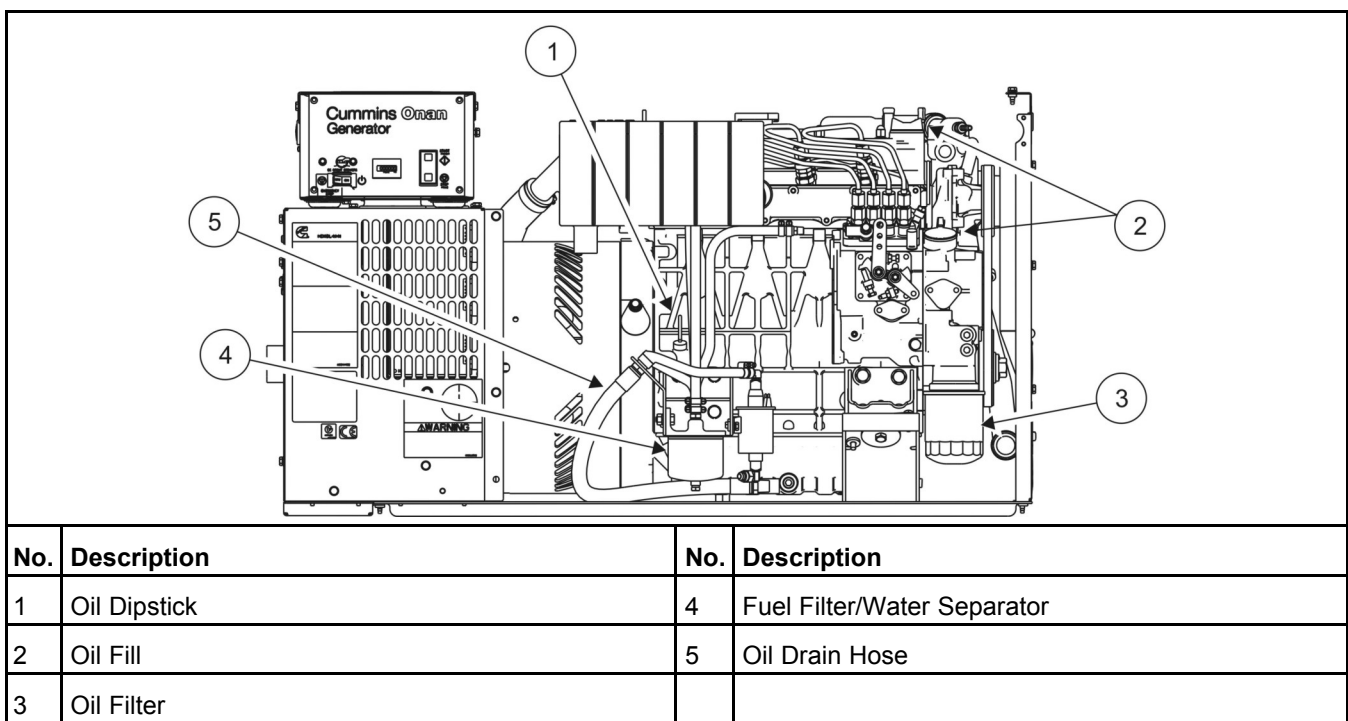

FIGURE 15. SERVICE POINT LOCATIONS - HDKBM, HDKBN

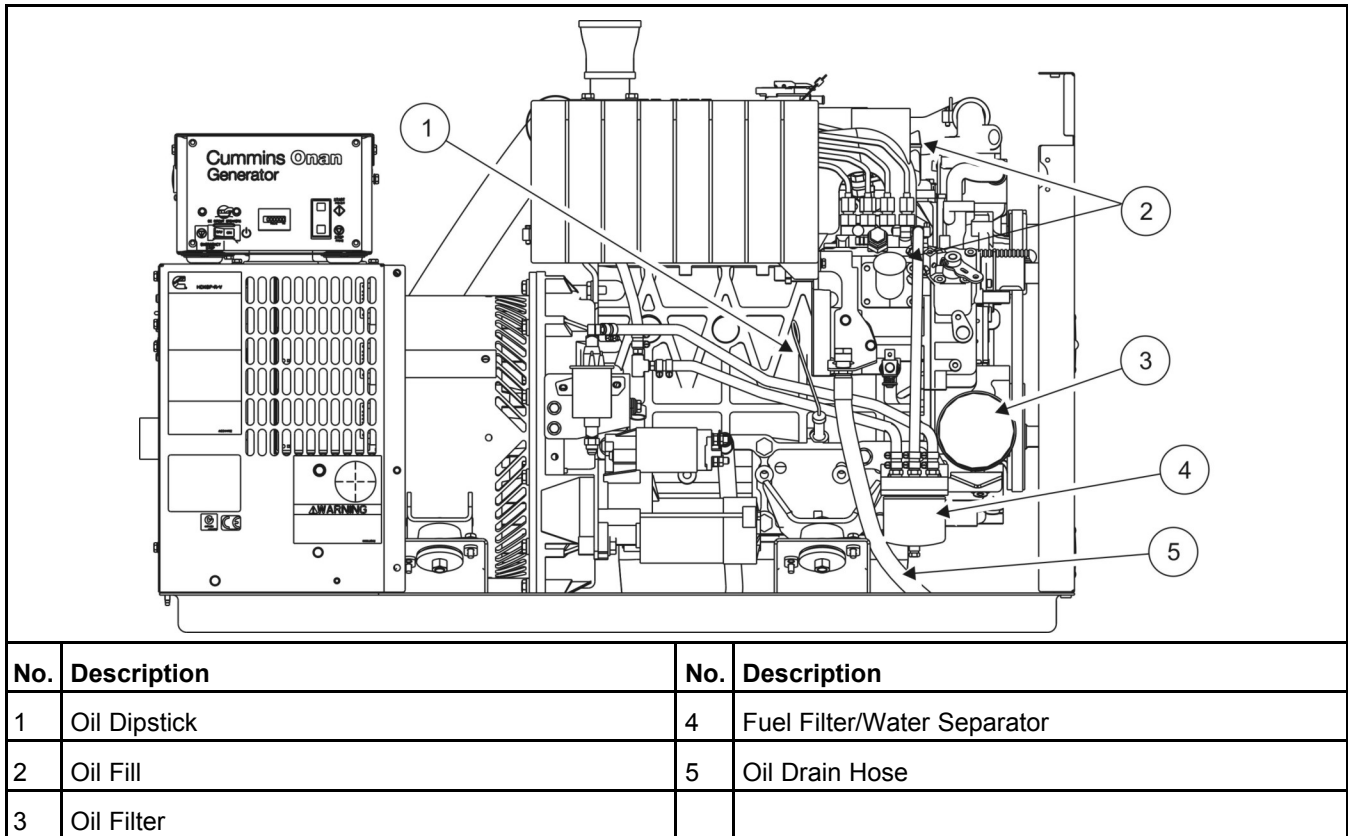

FIGURE 16. SERVICE POINT LOCATIONS - HDKBP, HDKBR, HDKBV

## 5.6 Maintaining the Fuel System

Keep dirt, water, and other contaminants from entering the fuel system and corroding or clogging fuel system components.

### 5.6.1 Fuel System

#### WARNING

***Diesel fuel leaks can lead to fire. Do not operate the generator set if operation causes fuel to leak.***

1. Check for leaks at the hose, tube, and pipe fittings in the fuel supply system while the generator set is running and while it is stopped.
2. Check flexible fuel hoses sections for cuts, cracks, abrasions, and loose hose clamps.
3. Make sure the fuel line does not rub against other parts of the vehicle or generator set.
4. Replace worn or damaged fuel line parts before leaks occur.

### 5.6.2 Fuel Recommendations

#### WARNING

***Diesel fuel is combustible and can cause severe personal injury or death. Do not smoke near fuel tanks or fuel-burning equipment, or in areas sharing ventilation with such equipment. Keep flames, sparks, pilot flames, electrical arcs and switches, and all other sources of ignition well away. Keep a multi-class ABC fire extinguisher handy.***

High quality diesel fuel is necessary for good performance and long engine life.

- The specifications for the type and sulfur content (ppm and weight percentage) of the diesel fuel used must comply with all emissions regulations applicable in the areas where the generator set is to be operated.
- Diesel fuels meeting ASTM D975 or EN 590 specifications are recommended. Use Grade 1-D diesel fuel.
  - When the ambient temperature is below  $-10\text{ }^{\circ}\text{C}$  ( $14\text{ }^{\circ}\text{F}$ ), a minimum Cetane number of 45 is recommended.
  - When the ambient temperature is below  $-20\text{ }^{\circ}\text{C}$  ( $-4\text{ }^{\circ}\text{F}$ ) or elevation is above 1500 m (5000 ft), a minimum Cetane number of 50 is recommended.
- Current US EPA regulations for non-road engines limit diesel fuel sulfur content to a maximum of 500 ppm (0.05% weight).
  - Use Grade 2-D S500 or 2-D S15 diesel fuel.
  - When the ambient temperature is below  $-10\text{ }^{\circ}\text{C}$  ( $14\text{ }^{\circ}\text{F}$ ), use Grade 1-D S500 or 1-D S15 diesel fuel.

#### NOTICE

**Beginning in the year 2010, US EPA regulations limit diesel fuel sulfur content to a maximum of 15 ppm (0.0015% weight).**

- Do not use diesel fuel with a sulfur content greater than 10,000 ppm (1.0% weight).



- Diesel fuel must meet the ASTM D975 standard for lubricity and pass a minimum load level of 3100 grams as measured by ASTM D6078, or maximum scar diameter of 0.45 mm as measured by ASTM D6079 or ISO 12156-1.

### 5.6.2.1 Bio-diesel Fuels B5 – B20

B5 bio-diesel fuel that meets industry specifications and quality is suitable for use with this generator set.

Before using bio-diesel fuel blends above B5 and up to B20, the following conditions must be verified:

- The vehicle propulsion engine is capable of using B20 when sharing the same fuel tank.
- The OEM has installed a B20 compatible fuel line from the fuel tank to the generator set.
- The OEM has installed a water separator in the fuel line just before the generator set.

For bio-diesel blends above B5 and up to B20, Cummins recommends that the fuel meet the specifications outlined in ASTM D7467. The bio-diesel component of this fuel blend must meet ASTM D6751 or EN14214, and the petroleum diesel component must meet ASTM D975. Blended bio-diesel fuels should be pre-blended and not made by customers.

#### **⚠ CAUTION**

***Market applications contain properties that can affect engine operating characteristics. It is highly recommended that use of these bio-diesel fuel blends be avoided or exercised with extra care. Use standard fuels in applications that experience seasonal usage, storage for periods exceeding 90 days, and extreme temperatures or humidity.***

The following bio-diesel fuel properties can affect engine performance:

- Poor oxidation stability can accelerate fuel oxidation. Fuel oxidation reduces generator performance. This effect is accelerated at increased ambient temperatures.
- Properties change at temperatures below  $-5\text{ }^{\circ}\text{C}$  ( $23\text{ }^{\circ}\text{F}$ ). Necessary precautions must be taken when operating the generator with bio-diesel blends in low ambient temperatures.
  - Fuel heater
  - Hose insulation
  - Additional anti-gel fuel additives.
- Bio-diesel fuel blends are an excellent medium for microbial growth. Microbes cause fuel system corrosion and premature filter plugging. The effectiveness of all commercially available conventional anti-microbial additives, when used in bio-diesel fuel, is not known. Consult your fuel and additive supplier for assistance.

If bio-diesel fuel is used for seasonal applications (stored more than 90 days), the generator must be purged before storage by running the engine on pure diesel fuel meeting ASTM D975 for a minimum of 30 minutes.

#### **NOTICE**

**The Cummins Warranty covers failures that are a direct result of defects in material or factory workmanship. Generator damage, service issues, and/or performance issues determined by Cummins to be caused by bio-diesel fuel blends not meeting the specifications outlined in the applicable Installation, Operator, and Service Manuals are not considered to be defects in material or workmanship and may affect your generator's warranty.**

### 5.6.3 Draining the Fuel Filter

The generator set may have a water-separator fuel filter. Check for other up-stream filters which may also need to be drained or replaced. Drain water and sediment more often than scheduled if fuel quality is poor, condensation cannot be avoided, or when a warning is being displayed for **WATER IN FUEL**.

Have towels and containers ready to clean, collect, and properly dispose of spilled or dripping fuel.

1. Using an insulated wrench, disconnect the negative (–) cable at the battery to prevent the engine from starting.
2. Open the front access door.
3. Remove drain plug on bottom of filter to drain water and sediment into a suitable container, about 120 ml (1/2 cup).
4. Re-install drain plug.
5. Replace the front access door.
6. Connect negative (–) battery cable.
7. Dispose of the drain-off in accordance with local environmental regulations.

### 5.6.4 Replacing the Fuel Filter

#### WARNING

##### ***Accidental or Remote Starting***

***Accidental or remote starting can cause severe personal injury or death.***

***Before removing a panel or access door, or before working on the generator set, use an insulated wrench to disconnect the negative (-) cable from the battery to prevent accidental starting.***

#### WARNING

##### ***Hot Surfaces***

***Contact with hot surfaces can cause severe burns, lacerations and liquid splash.***

***Wear appropriate PPE when working on hot equipment and avoid contact with hot surfaces.***

#### WARNING

***Gasoline is highly flammable and explosive and can cause severe personal injury or death. Do not smoke or turn electrical switches ON or OFF where fuel fumes, tanks, or equipment are present; or in areas sharing ventilation. Keep flames, sparks, pilot lights, arc-producing equipment and switches, and all other sources of ignition well away. Keep a type ABC fire extinguisher in the vehicle.***

Refer to [Section 5.1 on page 39](#) for scheduled fuel filter replacement. Replace the fuel filter if the engine lacks power.

1. Disconnect the negative (–) cable at the battery to prevent the engine from starting.
2. Remove the front access door.
3. Let engine cool down to prevent igniting any fuel that may be spilled when disconnecting the fuel filter.
4. Loosen the fuel line hose clamps and remove the fuel filter. Plug the fuel lines to prevent fuel leakage and vapor accumulation.

5. Connect the new fuel filter to the fuel line.
6. Prime the engine for at least 30 seconds to fill the new fuel filter. Check for leaks as the generator set runs for several minutes.
7. Tighten the clamps, if necessary.
8. Replace the front access door.
9. Connect the negative (-) cable at the battery.
10. Dispose of the old filter in accordance with local environmental regulations.

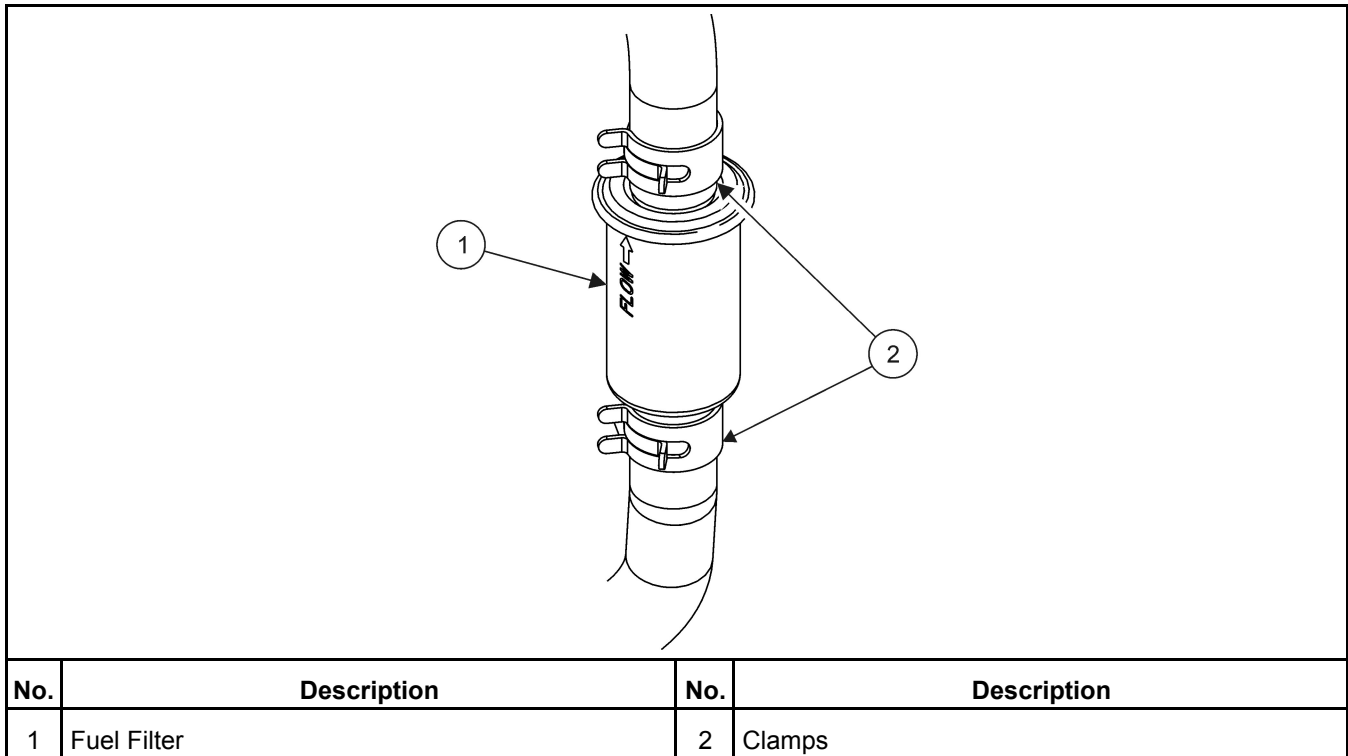

FIGURE 17. FUEL FILTER

### 5.6.5 Replacing the Fuel Filter

**⚠ WARNING**

**Accidental or Remote Starting**  
*Accidental or remote starting can cause severe personal injury or death.*  
*Before removing a panel or access door, or before working on the generator set, use an insulated wrench to disconnect the negative (-) cable from the battery to prevent accidental starting.*

**⚠ WARNING**

**Hot Surfaces**  
*Contact with hot surfaces can cause severe burns, lacerations and liquid splash.*  
*Wear appropriate PPE when working on hot equipment and avoid contact with hot surfaces.*

**⚠ WARNING**

***Gasoline is highly flammable and explosive and can cause severe personal injury or death. Do not smoke or turn electrical switches ON or OFF where fuel fumes, tanks, or equipment are present; or in areas sharing ventilation. Keep flames, sparks, pilot lights, arc-producing equipment and switches, and all other sources of ignition well away. Keep a type ABC fire extinguisher in the vehicle.***

Refer to [Section 5.1 on page 39](#) for scheduled fuel filter replacement. Replace the fuel filter if the engine lacks power.

1. Let engine cool down to prevent igniting any fuel that may be spilled when disconnecting the fuel filter.
2. Remove the fuel line from the fuel filter. Plug the fuel line to prevent fuel leakage and vapor accumulation.
3. Run the generator set until it runs out of fuel and let it cool down.
4. Disconnect the negative (-) cable at the battery to prevent the engine from starting.
5. Unscrew the filter from the fuel pump.
6. Install the new fuel filter by hand and tighten securely.
7. Connect the fuel filter to the fuel line.
8. Prime the engine for at least 30 seconds to fill the new fuel filter. Check for leaks as the generator set runs for several minutes.
9. Tighten the connections, if necessary.
10. Connect the negative (-) cable at the battery.
11. Dispose of the old filter in accordance with local environmental regulations.

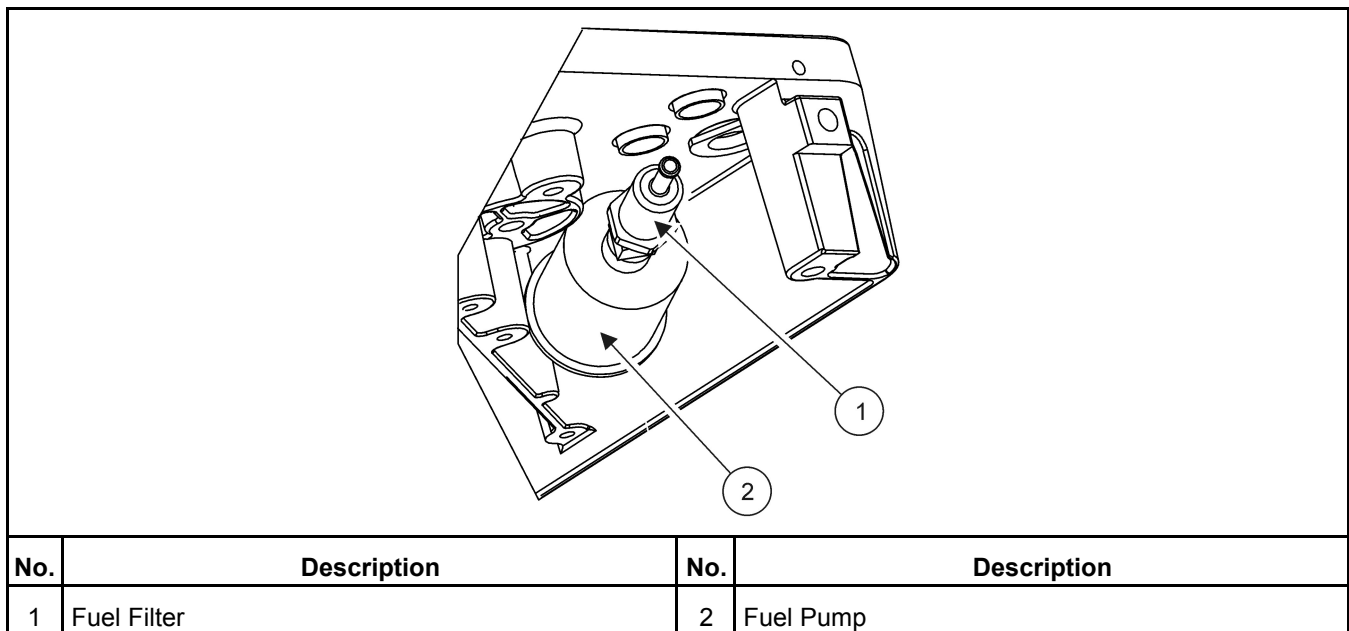
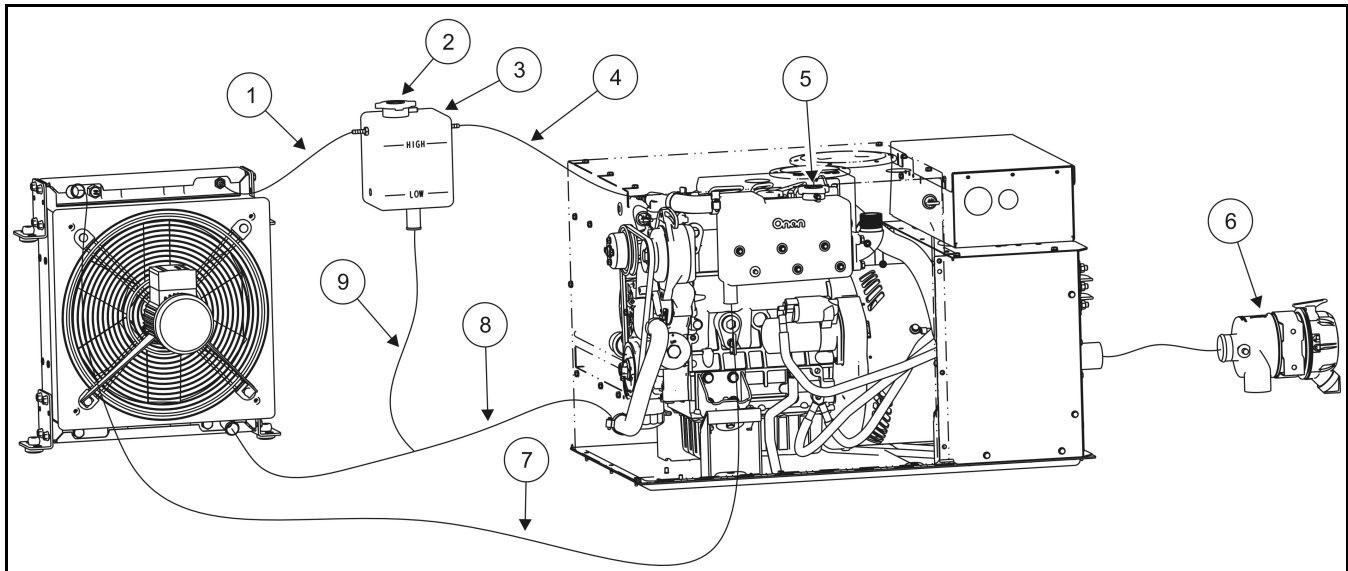

**FIGURE 18. FUEL FILTER**

## 5.7 Maintaining the Cooling System

The engine cooling system is filled with a 50/50 mixture of ethylene glycol antifreeze and water when the generator set leaves the factory. The mixture is suitable for temperatures down to -37 °C (-34 °F).

### 5.7.1 Cooling System – HDKBL



No.	Description	No.	Description
1	Air Vent Hose - Connects to heat exchanger hose barb.	6	Air Filter
2	Coolant Fill Cap	7	Upper Heat Exchanger Hose - Coolant Outlet
3	Coolant Fill/Deaeration Tank	8	Lower Heat Exchanger Hose - Coolant Inlet
4	Air Vent Hose - Connects to thermostat housing hose barb.	9	Coolant Fill Hose
5	Exhaust Manifold Pressure Cap - Do Not Remove - Use Remote Tank Pressure Cap		

FIGURE 19. COOLING SYSTEM – HDKBL (SPEC A & B)

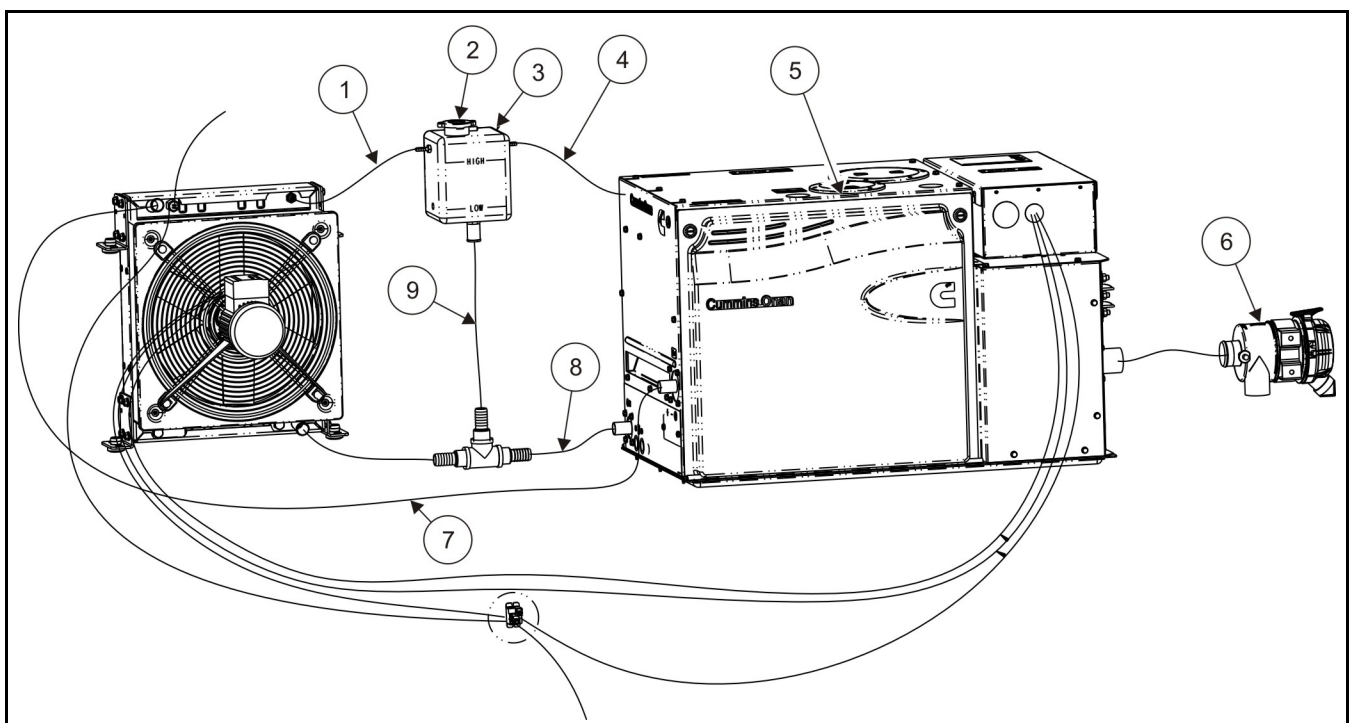

No.	Description	No.	Description
1	Air Vent Hose - Connects to heat exchanger hose barb.	6	Air Filter
2	Coolant Fill Cap	7	Upper Heat Exchanger Hose - Coolant Outlet
3	Coolant Fill/Deaeration Tank	8	Lower Heat Exchanger Hose - Coolant Inlet
4	Air Vent Hose - Connects to thermostat housing hose barb.	9	Coolant Fill Hose
5	Exhaust Manifold Pressure Cap - Do Not Remove - Use Remote Tank Pressure Cap		

**FIGURE 20. COOLING SYSTEM – HDKBL (SPEC C)**

### 5.7.2 Cooling System – HDKBM, HDKBN

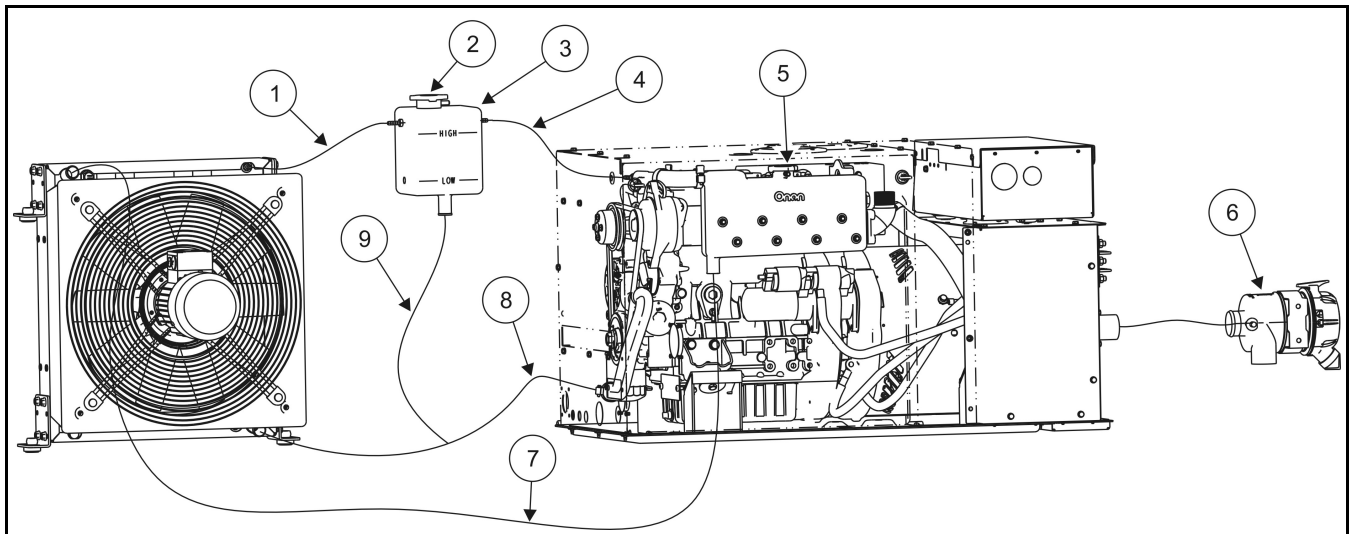

No.	Description	No.	Description
1	Air Vent Hose - Connects to heat exchanger hose barb.	6	Air Filter
2	Coolant Fill Cap	7	Upper Heat Exchanger Hose - Coolant Outlet
3	Coolant Fill/Deaeration Tank	8	Lower Heat Exchanger Hose - Coolant Inlet
4	Air Vent Hose - Connects to thermostat housing hose barb.	9	Coolant Fill Hose
5	Exhaust Manifold Pressure Cap - Do Not Remove - Use Remote Tank Pressure Cap		

**FIGURE 21. COOLING SYSTEM – HDKBM, HDKBN (SPEC A & B)**

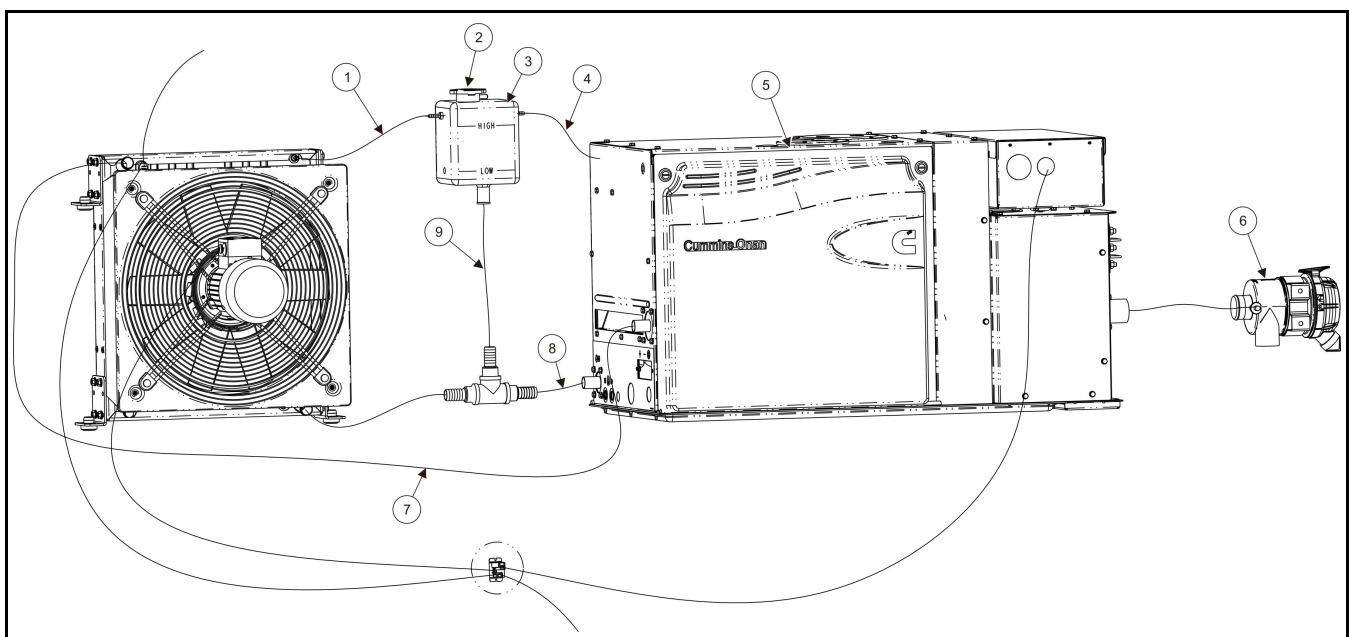

No.	Description	No.	Description
1	Air Vent Hose - Connects to heat exchanger hose barb.	6	Air Filter
2	Coolant Fill Cap	7	Upper Heat Exchanger Hose - Coolant Outlet
3	Coolant Fill/Deaeration Tank	8	Lower Heat Exchanger Hose - Coolant Inlet
4	Air Vent Hose - Connects to thermostat housing hose barb.	9	Coolant Fill Hose
5	Exhaust Manifold Pressure Cap - Do Not Remove - Use Remote Tank Pressure Cap		

**FIGURE 22. COOLING SYSTEM – HDKBM, HDKBN (SPEC C)**



### 5.7.3 Cooling System – HDKBP, HDKBR, HDKBV

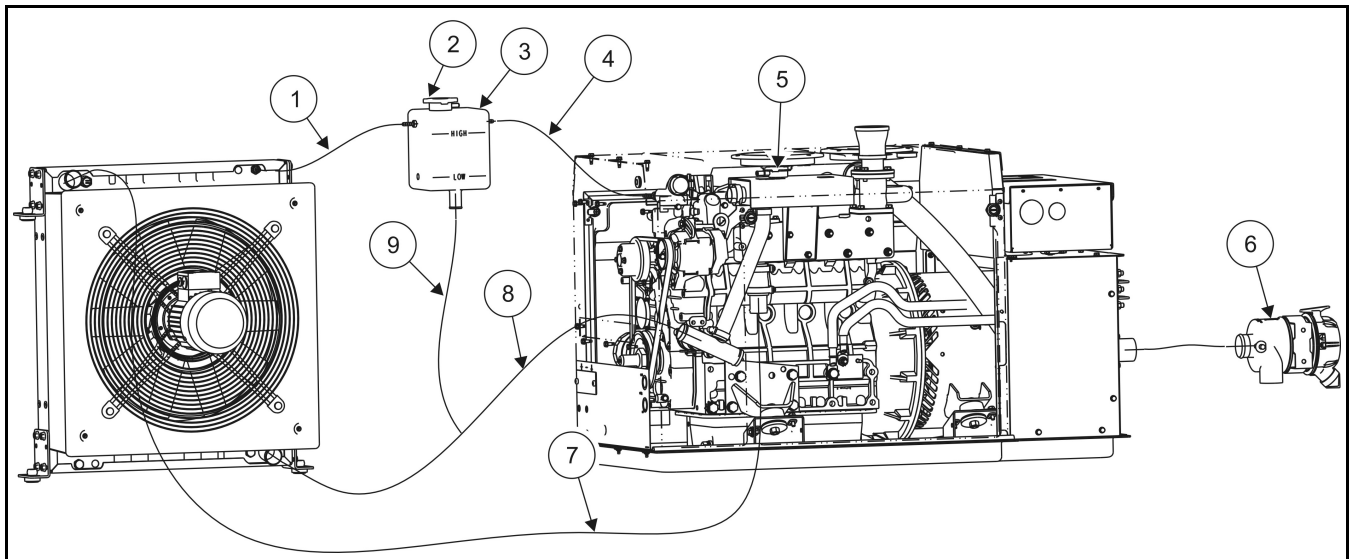

No.	Description	No.	Description
1	Air Vent Hose - Connects to heat exchanger hose barb	6	Air Filter
2	Coolant Fill Cap	7	Upper Heat Exchanger Hose - Coolant Outlet
3	Coolant Fill/Deaeration Tank	8	Lower Heat Exchanger Hose - Coolant Inlet
4	Air Vent Hose - Connects to generator set tank hose barb	9	Coolant Fill Hose
5	Exhaust Manifold Pressure Cap - Do Not Remove - Use Remote Tank Pressure Cap		

**FIGURE 23. COOLING SYSTEM – HDKBP, HDKBR, HDKBV (SPEC A & B)**

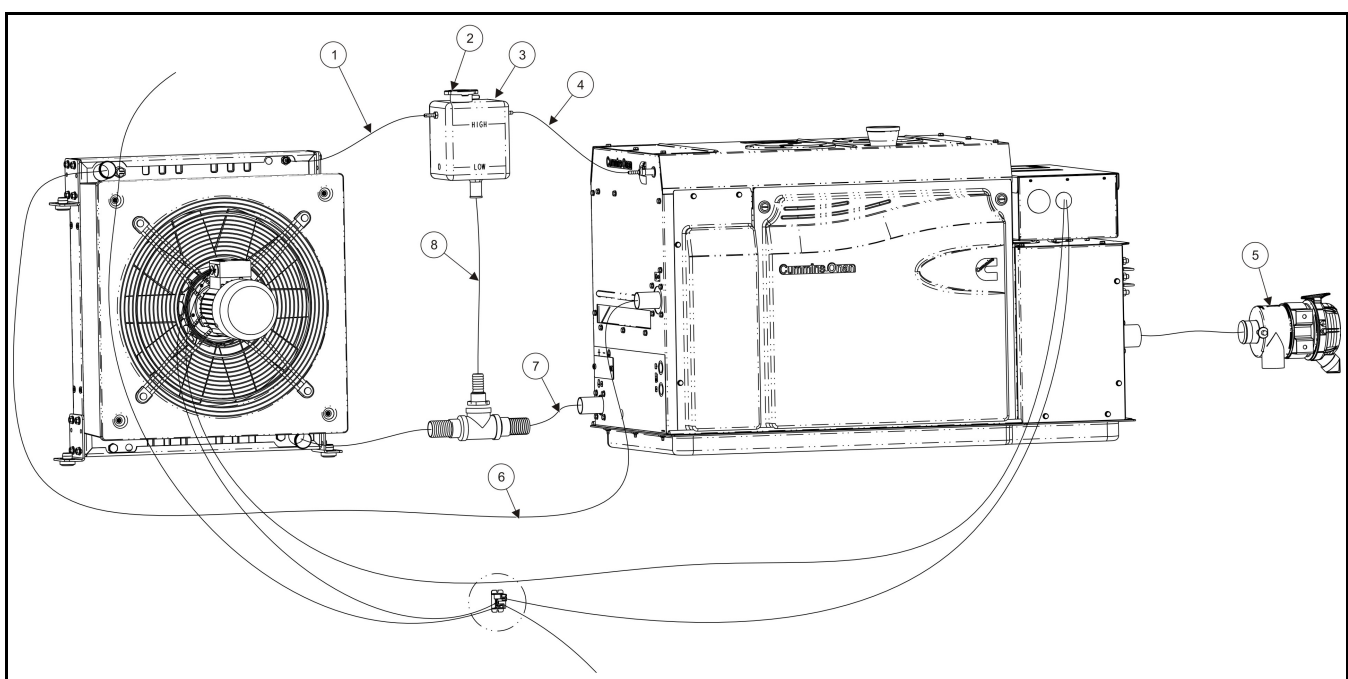

No.	Description	No.	Description
1	Air Vent Hose - Connects to heat exchanger hose barb	5	Air Filter
2	Coolant Fill Cap	6	Upper Heat Exchanger Hose - Coolant Outlet
3	Coolant Fill/Deaeration Tank	7	Lower Heat Exchanger Hose - Coolant Inlet
4	Air Vent Hose - Connects to generator set hose barb	8	Coolant Fill Hose

FIGURE 24. COOLING SYSTEM – HDKBP, HDKBR, HDKBV (SPEC C)

## 5.7.4 Pressure Cap

### ⚠ WARNING

**Scalding injury can occur as well as a large coolant leak. Do not remove the locked coolant cap on the exhaust manifold. Fill the system only through the remote-mounted coolant fill/deaeration tank.**

### ⚠ WARNING

**Hot pressurized coolant.**

**The failure to properly replace coolant caps can result in hot pressurized coolant escaping from the radiator fill necks, causing severe personal injury and engine damage.**

**Make sure the radiator cap is properly secured before operating the generator set.**

Replace the pressure (coolant fill) cap on the remote-mounted coolant fill/deaeration tank every two years (seals deteriorate and leak). Proper cooling system pressure (7 psi) is essential for optimal engine cooling and minimal coolant loss.

## 5.7.5 Coolant Hoses

Check for and replace hoses that leak or are damaged. Make sure all hoses are properly routed and connected.

## 5.7.6 Coolant Level

### ⚠ WARNING

*Scalding injury can occur as well as a large coolant leak. Do not remove the locked coolant cap on the exhaust manifold. Fill the system only through the remote-mounted coolant fill/deaeration tank.*

The remote-mounted coolant fill/deaeration tank is designed to fill the cooling system and expel air. See [Section 5.7.7 on page 57](#) for coolant specifications. Also see [Section 5.7.10 on page 58](#) for detailed instructions on refilling the cooling system.

1. Check coolant level in the coolant fill/deaeration tank and, if necessary, add coolant. Keep the level of coolant in the tank between **LOW** and **HIGH**. Use the recommended antifreeze mixture.
2. If the tank is empty, check for and repair any coolant leaks and refill the system through the fill neck on remote-mounted coolant fill/deaeration tank. Use the recommended antifreeze mixture.

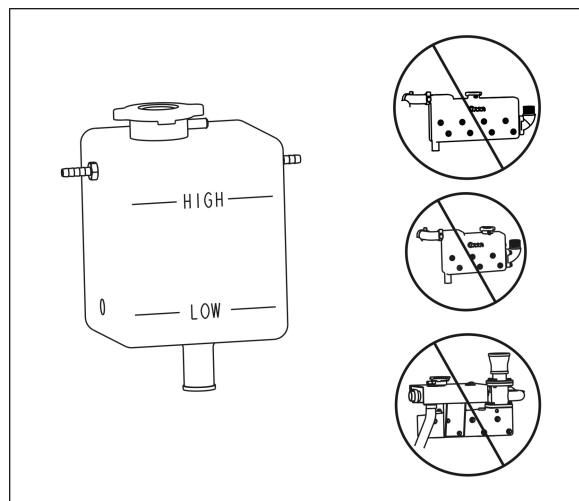

FIGURE 25. COOLANT FILL TANK

## 5.7.7 Coolant Recommendations

Use a high quality, fully formulated, ethylene glycol coolant with rust inhibitors and coolant stabilizers that meets ASTM D6210 Standard Specification for fully-formulated glycol base engine coolant for heavy-duty engines. This will provide corrosion protection, foam control, liner-pitting protection, and scale/deposit control.

Use fresh water that is low in minerals and corrosive chemicals for the coolant mixture. Distilled water is best.

See [Section 3.4 on page 15](#) regarding coolant capacity.

### ⚠ WARNING

*Ethylene glycol antifreeze is considered toxic. Dispose of it according to local regulations for hazardous substances.*

## 5.7.8 Replenishing Normal Coolant Loss

If the level of the coolant in the remote coolant/deaeration tank has fallen below the LOW mark,

1. Add coolant to a level between the LOW and HIGH marks.
2. Secure the pressure cap.
3. Start and run the engine for a couple of minutes to dislodge air pockets, then shut it down.
4. Recheck the coolant level in the tank, add coolant if necessary.
5. Secure the pressure cap and repeat above steps.

If the tank is empty, check for and repair any coolant leaks and refill the system.

1. Check to be sure the two air vent hoses from the deaeration tank are routed properly and connected to the air vent hose barbs on the heat exchanger and generator set.
2. Check to be sure the fill hose is properly connected to the lower heat exchanger hose.
3. Check to be sure that the upper and lower heat exchanger hoses are properly connected and routed to the heat exchanger and generator set.

## 5.7.9 Draining and Cleaning Cooling System

### WARNING

***Hot coolant spray can cause severe burns. Let the engine cool before releasing the pressure cap or removing the drain plug.***

Let the engine cool before removing the pressure cap.

1. Relieve any remaining pressure by turning the cap slowly, without pushing down.
2. When the pressure has been relieved, push down on the cap and turn it the rest of the way to withdraw it.

### WARNING

***Ethylene glycol antifreeze is considered toxic. Dispose of it according to local regulations for hazardous substances.***

3. Remove the coolant drain plug and drain the coolant into a suitable container.

Flush and clean the cooling system before refilling. Radiator cleaning chemicals are available at local auto parts stores. Follow cleaning and flushing instructions on the product.

## 5.7.10 Refilling Cooling System

### WARNING

***Scalding injury can occur as well as a large coolant leak. Do not remove the locked coolant cap on the exhaust manifold. Fill the system only through the remote-mounted coolant fill/deaeration tank.***

### NOTICE

**Filling a hot engine with cold water can cause cracks in the manifold, head, and block. Follow the manufacturer's instructions for cleaning and flushing.**

See [Section 5.7.7 on page 57](#) for coolant specifications. See [Section 3.4 on page 15](#) for coolant capacity.

### NOTICE

**Low coolant level can cause severe engine damage. Be sure the system is full.**

1. Close the engine block and heat exchanger drain valves (or check to be sure they are closed).
2. Remove the pressure cap on the remote-mounted coolant fill/deaeration tank.
3. Fill the system until the level is between LOW and HIGH. The system will fill only as fast as the air can escape.
  - For applications where the heat exchanger is located above the generator set, unscrew the temperature switch in the top of the heat exchanger to vent additional air from the system. Secure temperature switch when coolant begins to appear. Add coolant if necessary.
4. Allow the system to stabilize for a few minutes and add coolant if necessary.
5. Secure the pressure cap.
6. Start and run the generator set to deaerate the cooling system.
  - Run the generator set until the heat exchanger fan cycles on and off 2-3 times. Initial startup time of the fan depends on generator set load and environmental or application conditions.
  - As air is purged from the system the coolant level in the fill/deaeration tank may decrease.
7. If the tank completely empties, shut the generator set off, remove pressure cap, and add coolant.
8. Secure the pressure cap before re-starting the generator set.
  - This process may need to be repeated. Continue running the generator set until the coolant level in the tank stabilizes. The coolant level in the tank will vary slightly during generator set and fan operation due to thermal expansion. This is normal.
9. Shut the generator set off and allow the engine to cool.
10. Check the coolant level, add coolant if necessary after the engine cools. Be sure to secure the pressure cap.
11. Check coolant levels each day and after every 8 hours of operation.

## 5.7.11 Heat Exchanger

Maintenance for the heat exchanger assembly is minimal; however periodic inspection of the exterior of the heat exchanger/radiator for obstructions and loose or damaged hardware and periodic cleaning of the core fins, fan blades, and fan motor are necessary for the system to provide best performance.

Remove all dirt, dust, or foreign material with a soft brush or cloth. Use care to avoid damaging the fins. If available, use low pressure compressed air or water stream (maximum of 35 psi/242 kPa), in opposite direction of normal air flow to clean radiator. If using water, protect the fan motor, wiring harnesses, and other electrical equipment from over spray.

Refer to the Operator Manual for periodic maintenance schedule and procedures.

## 5.7.12 Fan Blades and Motor

- Clean the fan blades and motor regularly (see [Section 5.1 on page 39](#)). Dust and large amounts of foreign material that collect on the fan blades and motor body, or obstruct the motor air inlet, will cause the motor to overheat and lower fan performance, as well as causing fan imbalance.
- Check that there are no obstructions between moving parts and fan guard or shroud.

- Check connections in the terminal box to ensure they are secure.

## 5.7.13 Replacing the Thermostat

### WARNING

#### ***Accidental or Remote Starting***

***Accidental or remote starting can cause severe personal injury or death.***

***Before removing a panel or access door, or before working on the generator set, use an insulated wrench to disconnect the negative (-) cable from the battery to prevent accidental starting.***

### WARNING

#### ***Hot Coolant***

***Hot coolant is under pressure and can spray, causing severe burns when loosening the pressure cap or opening the coolant drain.***

***Let the engine cool before loosening the pressure cap. Wear safety glasses.***

See [Section 5.1 on page 39](#) for scheduled replacement.

1. Use an insulated wrench to disconnect the negative battery cable at the battery to prevent the engine from starting. Let the engine cool and remove the front access door.
2. Remove the pressure cap.
3. Drain the cooling system following procedure in previous section - Draining and Cleaning the Cooling System.
4. Remove the two thermostat housing bolts and pull off the housing, thermostat, and gasket. The hose does not need to come off.
5. Clean off the gasket area and install the new thermostat and gasket. Apply Three Bond 1215 liquid sealant or equivalent to the top side of the gasket.
6. Replenish any lost coolant (refer to the previous section - Refilling the Cooling System), secure the pressure cap, secure the top of the enclosure and access door, and reconnect the negative battery cable.

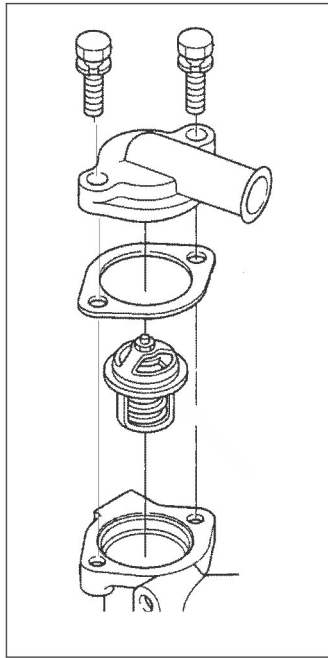

FIGURE 26. TYPICAL THERMOSTAT AND HOUSING

## 5.7.14 Adjusting V-Belt Tension

### **⚠ WARNING**

#### ***Accidental or Remote Starting***

***Accidental or remote starting can cause severe personal injury or death.***

***Before removing a panel or access door, or before working on the generator set, use an insulated wrench to disconnect the negative (-) cable from the battery to prevent accidental starting.***

1. Use an insulated wrench to disconnect the negative (-) cable at the battery to prevent the engine from starting.
2. Remove the belt guard or enclosure top panel and access doors.
3. Loosen the alternator pivot bolt first and then the adjusting bracket bolt on top.
4. Pivot the alternator out to tighten belt tension. Hold tension by tightening the tension adjusting bolt and then check tension by applying 10 kg (20 pounds) to the middle of the pulley span. Belt tension is correct when deflection is 10 mm (3/8 inch).
5. Tighten the alternator bolts when tension is correct.
6. Tighten the bolts, secure the belt guard or enclosure and reconnect the negative battery cable.

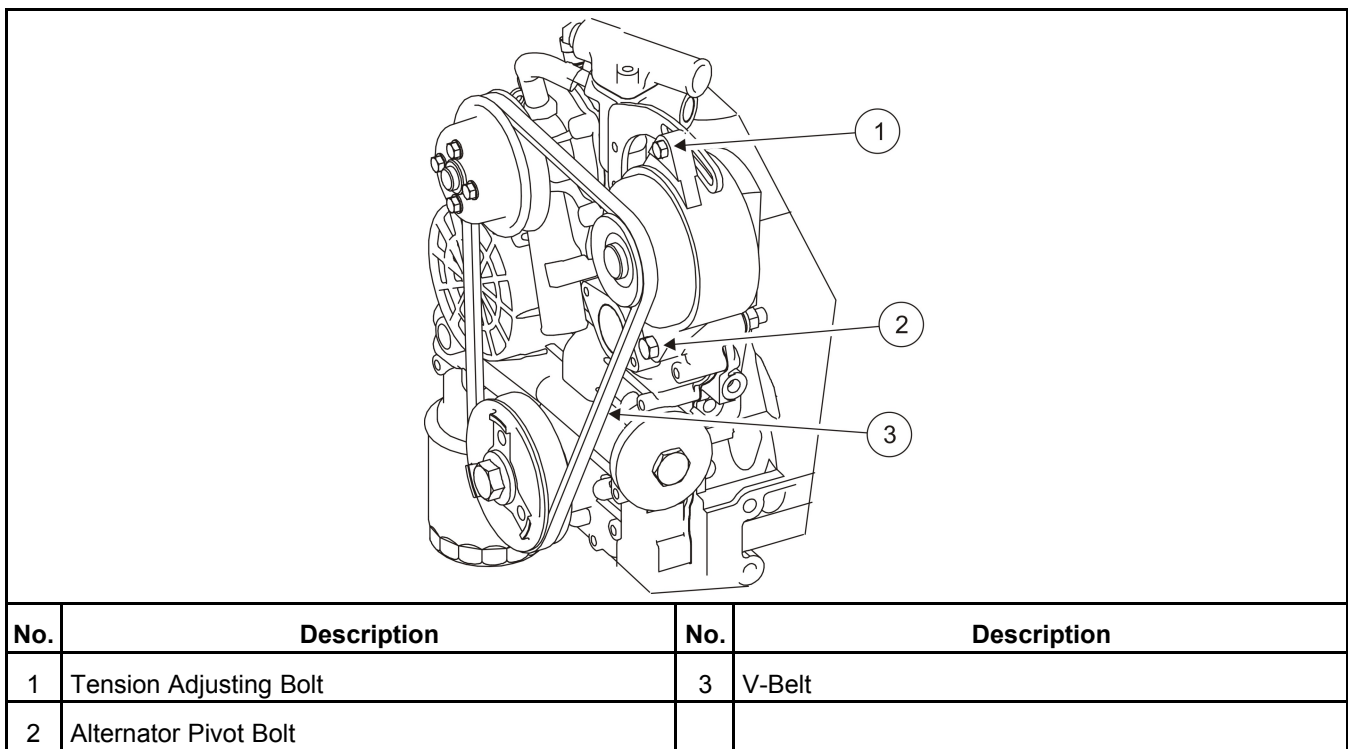

FIGURE 27. ADJUSTING V-BELT TENSION

## 5.8 Exhaust System

**⚠ WARNING**

***EXHAUST GAS IS DEADLY! Do not operate the generator set if there is an exhaust leak or any danger of exhaust gasses entering or being drawn into the vehicle.***

**⚠ WARNING**

***Grass or brush in contact with the exhaust system can cause fire. Do not park the vehicle in high grass or brush.***

1. Look and listen for exhaust system leaks while the generator set is running. Shut down the generator set if a leak is found and have it repaired before operating.
2. Look for openings or holes between the generator set compartment and vehicle cab or living space if the generator set engine sounds louder than usual. Have all such openings or holes closed off and sealed to prevent exhaust gases from entering the vehicle.
3. Replace dented, bent, or severely rusted sections of the tailpipe and make sure the tailpipe extends at least 25.4 mm (1 in) beyond the perimeter of the vehicle.
4. Park the vehicle so that generator set exhaust gases disperse away from the vehicle. Barriers such as walls, snow banks, high grass, brush, and other vehicles can cause exhaust gases to accumulate in and around the vehicle.
5. Do not operate power ventilators or exhaust fans while the vehicle is standing with the generator set running. The ventilator or fan can draw exhaust gases into the vehicle.
6. Check all CO monitors to assure proper operation.



## 5.9 Mechanical System

### **⚠ WARNING**

***Compressed air, pressure washers, and steam cleaners can cause severe eye injury. Always wear safety glasses when using.***

1. Look for mechanical damage and listen for unusual noises and vibrations.
2. Check the generator set mounting bolts.
3. Check to see that the generator set air inlet and outlet openings are not clogged with debris or blocked.
4. Clean accumulated dust and dirt from the generator set. Do not clean the generator set while it is running or still hot. Protect the generator, air cleaner, control panel, and electrical connections from water, soap, and cleaning solvents.

## 5.10 Replacing the Air Filter Element

The air filter for the engine intake air system is remotely mounted from the generator set. Refer to [Section 5.1.1 on page 39](#) for replacement schedule. Replace more often in dusty environments.

To replace the air filter element:

1. Lift the lever on the filter assembly cover and rotate to remove.
2. Pull out filter element and replace with a new one.
3. Install assembly cover. Be sure lever engages to lock cover in place.

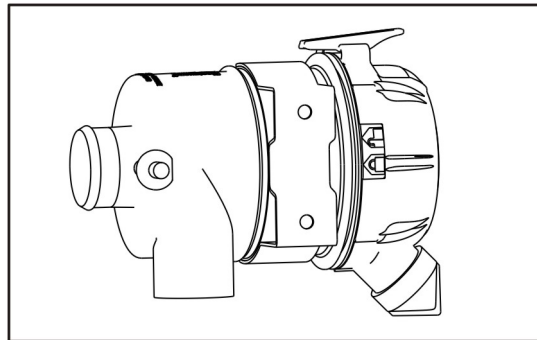

**FIGURE 28. AIR FILTER**

## 5.11 Storing the Generator Set

Proper storage is essential for preserving top generator set performance and reliability. If the generator set is not going to be exercised on a regular basis and not be used for more than 120 days, the generator set should be prepared for storage.

### **⚠ WARNING**

***Carbon monoxide is deadly and can accumulate to dangerous levels in garages and other confined spaces. Disable the automatic generator starting feature before storing the vehicle.***

1. Disable the automatic generator set starting feature.

2. Change the engine oil and attach a tag indicating the oil grade viscosity.
3. Disconnect the battery cables, negative (-) cable first, from the starting battery and store the battery according to the battery manufacturer's recommendations.
4. Position the line circuit breaker to OFF.

## 5.12 Returning the Generator Set to Service

1. Check the oil tag on the generator set and change the oil if the viscosity indicated is not appropriate for the temperatures expected.
2. Reconnect the starting battery (negative [-] cable last).
3. Replace the air filter element. Use new air filter element if it is dirty.
4. Inspect the generator set.
5. Prime the generator set fuel system by positioning the control switch to **STOP/PRIME** for 30 seconds. The status indicator stays on while the pump is on.
6. Start the generator set.
7. Position the line circuit breaker to ON when the generator set is ready to power loads.

# 6 Troubleshooting

---

## 6.1 Overview

### **WARNING**

*Hot engine parts can cause severe burns. Always allow the engine to cool down before performing any maintenance or service.*

The following paragraphs provide fault code faults and symptom-based faults. If a problem is not resolved after taking the corrective actions suggested, contact a local dealer or distributor. See [Section 2.4 on page 10](#).

### **NOTICE**

**Maintaining engine oil level, keeping battery connections clean and tight, watching the fuel gauge, not overloading the generator set, etc. will prevent most shutdowns.**

### **NOTICE**

**When the generator set and vehicle engine share a common fuel tank, the fuel dip tubes are usually arranged so that the generator set will run out of fuel first. Marking the generator set empty point on the fuel gauge will make it easier to tell when to stop the generator set before running it out of fuel.**

## 6.2 Troubleshooting with Digital Display

If a fault shutdown occurs the ALARM status lamp on the Digital Display will blink and the LCD screen will display the Fault Number, a description of the fault and the hour the fault occurred in total generator set running time.

The fault will be displayed until it is cleared. Touch any button to clear the fault. The display will turn off in 5 minutes after the fault has been cleared.

## 6.3 Fault Codes

The generator set control contains extensive diagnostics to detect shutdown faults. Following a fault shutdown, the control indicates the fault code by flashing the numeric code on the status indicator in the control switch.

Determine the fault code as follows:

- 1 flash indicates a high engine coolant temperature.
- 2 flashes indicates a low oil pressure fault (Code 2 fault).
- 3 flashes indicates a service fault (Code 3 fault).
  1. Press **STOP/PRIME** on the control switch once to have the 2-digit service fault code flash.

The 2-digit code consists of two sets of flashes. The first set of flashes represents the 10s digit of the code. After a brief pause, the second digit of the code flashes representing the unit digit of the code. This is followed by a long pause before repeating the flashing of the fault code.

For example, Fault Code 36 appears as: blink-blink-blink—pause—blink-blink-blink-blink-blink-blink—long pause—repeat

2. Press **STOP/PRIME** to stop flashing the fault code.
- 4 flashes indicates that cranking exceeded 30 seconds without the engine starting (Code 4 fault).

#### NOTICE

**Fault codes 33 and 34 are not assigned as fault codes. Be careful of interpreting Fault Codes 3 and 4 as second-level faults.**

The fault code stops flashing after 5 minutes. Pressing **STOP/PRIME** 3 times within 5 seconds causes the fault code to resume flashing.

#### NOTICE

**The last fault logged continues to flash even though the condition that caused the shutdown has been corrected.**

## 6.3.1 Code 1 - Engine Over Temperature

Indicates that, during normal operation, the engine coolant temperature exceeded 115 °C (239 °F) for 10 seconds.

### A. Check Engine Coolant Level

If coolant level is low, add coolant as necessary and repair any leaks.

### B. Check for Blockages

1. If an air inlet or outlet opening on the bottom of the generator set is blocked, remove objects.
2. If dirt is fouling the radiation fins, clean dirt out.

#### NOTICE

**Compressed air or washing with water can be helpful in removing debris from heat exchangers. Do not allow copious amounts of water to enter generator set components. A pressure washer is NOT advised for cleaning heat exchangers.**

### C. Reduce Load

Reduce the number of connected appliances, especially air conditioners and battery chargers. (Review load management in [Section 4.4.](#))

## 6.3.2 Code 2 - Low Oil Pressure

Indicates that the low oil pressure cutoff switch did not open.

### **A. Check Engine Oil Level**

1. If the dipstick indicates oil is low, add oil.
2. If oil is above the full mark on dipstick, drain excess oil.

## **6.3.3 Code 3 - Service Check**

See second-level fault code.

## **6.3.4 Code 4 - Over Crank**

Indicates that cranking exceeded 30 seconds without engine starting.

### **A. Check Air Filter Element**

Replace the air filter if dirty.

### **B. Replace Engine Oil**

Replace engine oil with oil of proper viscosity for the ambient temperature.

<b>NOTICE</b>
<b>High oil viscosity can slow down cranking speed.</b>

### **C. Check Fuel Fittings**

1. Tighten any fuel fitting if there is a fuel or air leak.
2. Reprime the engine fuel system by positioning the control switch to **STOP/PRIME** for 30 seconds.

### **D. Replace Fuel Filter**

## **6.3.5 Code 5 - Warning Shutdown due to CO**

Indicates that dangerous levels of carbon monoxide are in the vehicle.

### **A. Exit Vehicle Immediately**

Get everyone out into fresh air immediately and seek medical attention.

## **6.3.6 Code 12 - Over Voltage**

Indicates the control is unable to maintain rated voltage.

### **A. Contact Local Dealer or Distributor**

## **6.3.7 Code 13 - Under Voltage**

Indicates the control is unable to maintain rated voltage.

---

**A. Reduce Load**

Reduce the number of connected appliances, especially air conditioners and battery chargers. (Review load management in [Section 4.4.](#))

**6.3.8 Code 14 - Over Frequency**

Indicates the engine governor is unable to maintain rated frequency.

**A. Contact Local Dealer or Distributor****6.3.9 Code 15 - Under Frequency**

Indicates the engine governor is unable to maintain rated frequency.

**A. Reduce Load**

Reduce the number of connected appliances, especially air conditioners and battery chargers. (Review load management in [Section 4.4.](#))

**6.3.10 Code 19 - Governor Actuator**

Indicates the control sensed an open or shorted circuit.

**A. Contact Local Dealer or Distributor****6.3.11 Code 22 - Governor Actuator Overload**

Indicates the duration of operation is near full-duty cycle beyond design limit.

**A. Reduce Load**

Reduce the number of connected appliances, especially air conditioners and battery chargers. (Review load management in [Section 4.4.](#))

**B. Check Air Filter Element**

Replace the air filter if dirty.

**C. Check Exhaust System**

If exhaust system is blocked, remove blockage.

**6.3.12 Code 24 - Faulty Temperature Sender**

Indicates the control sensed open sender.

**A. Contact Local Dealer or Distributor****6.3.13 Code 27 - Voltage Sense**

Indicates the control is unable to sense output voltage.

---

## A. Contact Local Dealer or Distributor

### 6.3.14 Code 29 - High Battery Voltage

Indicates that voltage across the battery system is greater than 19 Volts.

#### A. Check Battery

1. Check battery bank connections and reconnect if necessary so that the 12 Volt batteries serving the generator set are connected in parallel (12 Volt) rather than in series (24 Volt).
2. Select a lower battery boost charge rate.

### 6.3.15 Code 32 - Low Cranking Speed

Indicates that cranking speed is less than 180 RPM for more than 2 seconds.

#### A. Check Battery

1. Clean and tighten the positive (+) and negative (-) battery cable connections at the battery and at the generator set.
2. Recharge or replace the battery. Refer to the battery manufacturer's recommendations.

#### B. Replace Engine Oil

Replace engine oil with oil of proper viscosity for the ambient temperature.

<b>NOTICE</b>
High oil viscosity can slow down cranking speed.

### 6.3.16 Code 35 - Control Card Failure

Indicates that a microprocessor EEPROM error occurred during self test.

#### A. Contact Local Dealer or Distributor

### 6.3.17 Code 36 - Engine Stopped

Indicates that the engine stopped without receiving a command from the control.

#### A. Check Fuel Level

1. If fuel level is low, fill the fuel tank.

<b>NOTICE</b>
The generator set fuel pickup tube could be higher up in the fuel tank than the vehicle engine pickup.

2. Prime the engine fuel system by positioning the control switch to **STOP/PRIME** for 30 seconds.

#### B. Check Air Filter Element

Replace the air filter if dirty.

---

## C. Check for Mechanical Damage

### 6.3.18 Code 38 - Over Current (Field Overload)

Indicates low power factor loads.

#### A. Reduce Load

Reduce the number of connected appliances, especially air conditioners and battery chargers. (Review load management in [Section 4.4.](#))

#### B. Check Appliances for Proper Operation

Have air conditioners and other appliances checked for proper operation.

### 6.3.19 Code 41 - Generator Rotor

Indicates control is unable to sense field or output voltage.

#### A. Contact Local Dealer or Distributor

### 6.3.20 Code 42 - Processor

Indicates that a microprocessor ROM error occurred during self test.

#### A. Contact Local Dealer or Distributor

### 6.3.21 Code 43 - Processor

Indicates that a microprocessor RAM error occurred during self test.

#### A. Contact Local Dealer or Distributor

### 6.3.22 Code 45 - Speed Sense

Indicates the control is unable to sense quadrature frequency.

#### A. Contact Local Dealer or Distributor

### 6.3.23 Code 48 - Generator Field Sense

Indicates the control is unable to sense field voltage.

#### A. Contact Local Dealer or Distributor

### 6.3.24 Code 57 - Over Prime

Indicates that priming exceeded 3 minutes.

#### A. Check Control Switch

Check for and remove any object that may be holding either control switch (remote or generator set) in the **STOP/PRIME** position.



### **6.3.25 Code 59 - Low Coolant Level**

Indicates that the engine coolant level fell below the optional coolant level sensor.

#### **A. Add Coolant**

Add coolant as necessary and repair leaks.

### **6.3.26 Code 61 - External Shutdown**

Indicates that the generator set was shut down by a fire suppression system or other external control.

#### **A. Make Repairs and Reset External Control**

1. Make all necessary repairs to the generator set and connected equipment.
2. Reset the external control that shut down the generator set.

## **6.4 Symptom Based**

Diagnosis of some problems involves observing system operation.

### **6.4.1 Status Indicator Not Working**

Indicates that there could be faulty connections or no battery voltage.

#### **A. Check Other Control Switch**

Try the generator set control switch if the remote control switch start doesn't work, and vice versa.

#### **B. Check Battery**

1. Clean and tighten the positive (+) and negative (-) battery cable connections at the battery and at the generator set.
2. Recharge or replace the battery. Refer to the battery manufacturer's recommendations.

### **6.4.2 Starting Batteries Run Down**

Indicates problem with batteries, connections, charging system, or parasitic loads.

#### **A. Check Battery**

1. Clean and tighten the positive (+) and negative (-) battery cable connections at the battery and at the generator set.
2. Recharge or replace the battery. Refer to the battery manufacturer's recommendations.

#### **B. Battery Charging System**

Install or service a battery charging system in the vehicle.

### **6.4.3 Starter Engages-Disengages**

Indicates cranking voltage dips below 6 Volts.

### **A. Use Vehicle to Start Generator Set**

Run the vehicle propulsion engine while trying to start the generator set—the battery charging alternator may be able to maintain starting voltage high enough to start the generator set.

### **B. Check Battery**

1. Clean and tighten the positive (+) and negative (–) battery cable connections at the battery and at the generator set.
2. Recharge or replace the battery. Refer to the battery manufacturer's recommendations.

### **C. Change Battery Cables**

Increase battery cable size or run parallel cables.

## **6.4.4 No Power—Generator Set Running, Status Light On**

Indicates line circuit breaker is **OFF**, or tripped due to short circuit or overload.

### **A. Check Line Circuit Breakers**

1. Turn on or reset the line circuit breaker on the generator set.
2. Turn on or reset the line circuit breaker on the main distribution panel in the vehicle.



This page is intentionally blank.



# Cummins Onan

Cummins Power Generation  
1400 73rd Ave. NE  
Minneapolis, MN 55432 USA  
Phone 1 763 574 5000  
Toll-free 1 800 888 6626  
Fax 1 763 574 5298

Copyright © 2024 Cummins Power Generation, Inc. All rights reserved.

Cummins, Onan, the "C" logo, and "Performance you rely on." are trademarks of Cummins Inc.

