

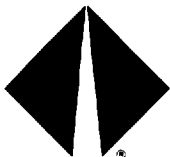

**Jacobs Vehicle Systems™**

**Jacobs Exhaust Brake™**

**Modelo EX466A-C**

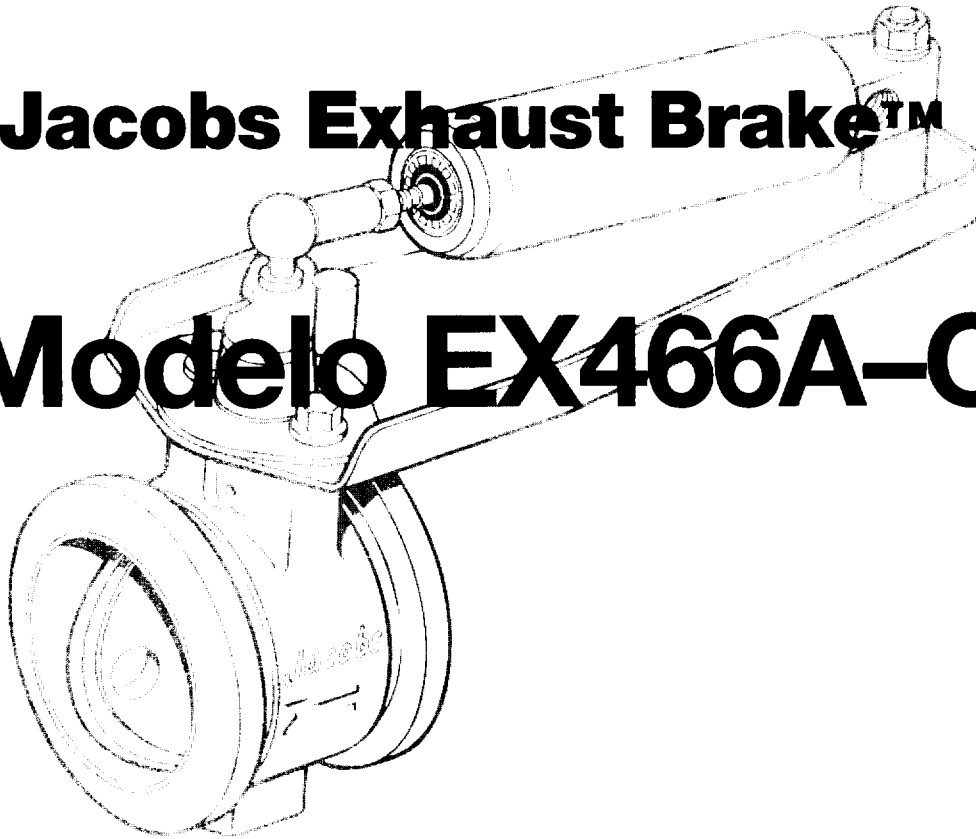

**INTERNATIONAL®**

**MANUAL DE PIEZAS**

## Notas de Aplicación

La información que se presenta en este manual estaba actualizada en el momento de la impresión y está sujeta a cambio sin previo aviso y sin responsabilidad.

Es posible que los vehículos equipados con frenos hidráulicos no posean un suministro de aire abordo. Estos vehículos requieren la instalación de un sistema de suministro de aire auxiliar. Para hacerlo, solicite el Grupo Neumático con Suministro de Aire, P/N J19482. Consulte las instrucciones incluidas con dicho grupo para obtener información sobre las piezas y la instalación.

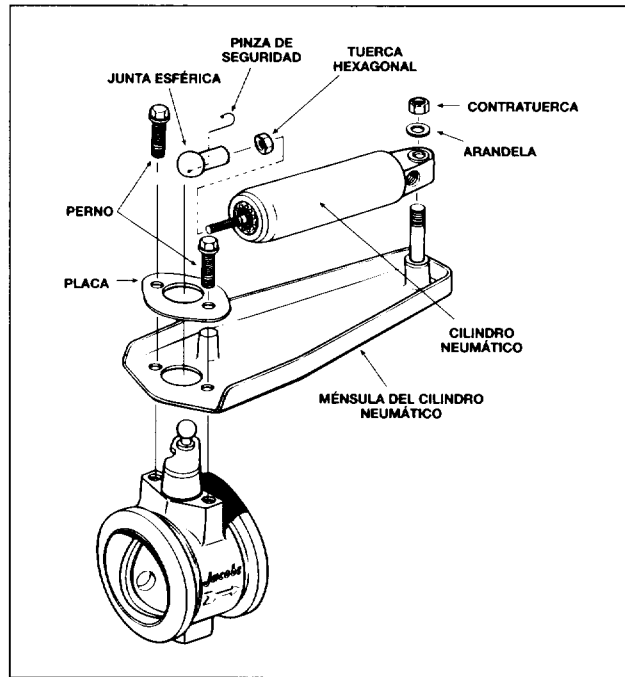

Vista ampliada del desglose de las piezas del conjunto del freno de escape

## Conjuntos del Freno de Escape y Piezas de Acoplamiento

III. Nro.	Número de Pieza	Descripción	Ctd./ Grupo
1	2015983C1	Empaquetadura	2
2	NVS	Tubo de turbina	1
3	NVS	Abrazadera en "V"	3
4	NSS	Tubo de escape	1
5	690695C91	Conjunto del freno para el Modelo EX466A-C	1

## Grupo de las Piezas de Conversión del Motor, P/N 1821043C91

NI	NVS	Balancín	12
NI	NVS	Cierre de muelle de válvula	24
NI	NVS	Conjunto del rotor	6
NI	NVS	Muelle de válvula de escape	6
NI	NVS	Empaquetadura de la cubierta de válvula	1
NI	NVS	Arandela de aislamiento de la cubierta de válvula	6
NI	NVS	Instrucciones	1

NI = No ilustrada

NVS = No se vende separadamente

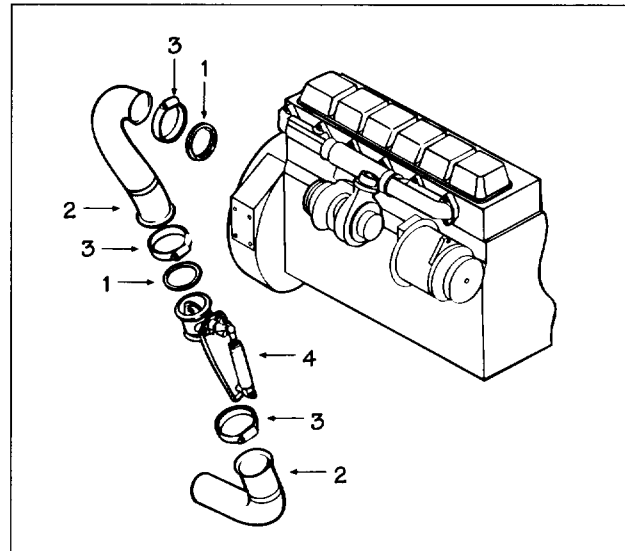

Jacobs Vehicle Systems  
22 East Dudley Town Road  
Bloomfield, CT 06002



Visitenos en la Internet:  
[www.jakebrake.com](http://www.jakebrake.com)

©1998 Jacobs Vehicle Systems, Inc.

Impreso en EE.UU.

## Grupo de Control del Motor (NVS)

III. Nro.	Descripción	Ctd./ Grupo
1	Conmutador	1
2	Abrazadera	1
3	Tornillo	2
4	Arandela sencilla	2
5	Arandela de presión	2
6	Lengüeta de desconexión rápida	2
7	Conjunto de diodo	1
8	Conjunto de tornillo	2
9	Perno de tapón hexagonal, M6 x 1.20	2
10	Arandela sencilla, 6 mm	2
11	Arandela de presión, 6 mm	2
12	Ménsula	1

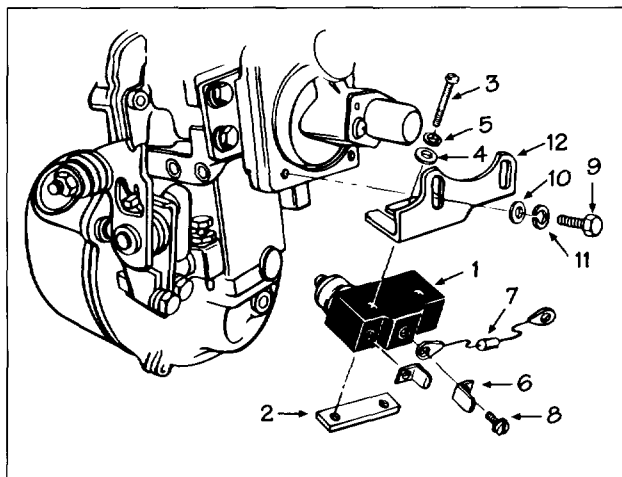

## Grupo del Conmutador del Embrague, P/N J12261

III. Nro.	Descripción	Ctd./ Grupo
1	Conmutador del embrague	1
2	Ménsula de montaje del conmutador	1
3	Tornillo de cabeza plana grande	2
4	Arandela de presión	2
5	Tuerca hexagonal	2
6	Empalme de tope	2
7	Ménsula de sobre recorrido	1
NI	Hoja de instrucciones	1

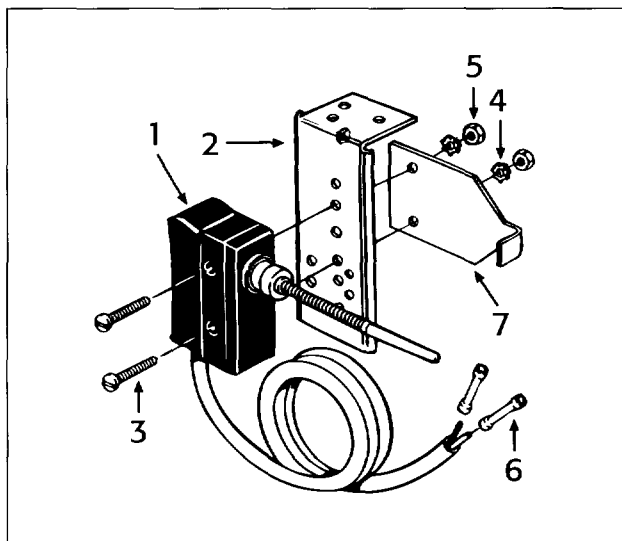

## Grupo del Conmutador del Tablero de Instrumentos, NVS

III. Nro.	Descripción	Ctd./ Grupo
NI	Conmutador del tablero de instrumentos	1
NI	Placa del conmutador (inglés)	1
NI	Placa del conmutador (español)	1
NI	Calcomanía del tablero de instrumentos (inglés)	1
NI	Calcomanía del tablero de instrumentos (español)	1

## Colector de Cables (NI), P/N J18899

NI - No ilustrada

NVS = No se vende separadamente

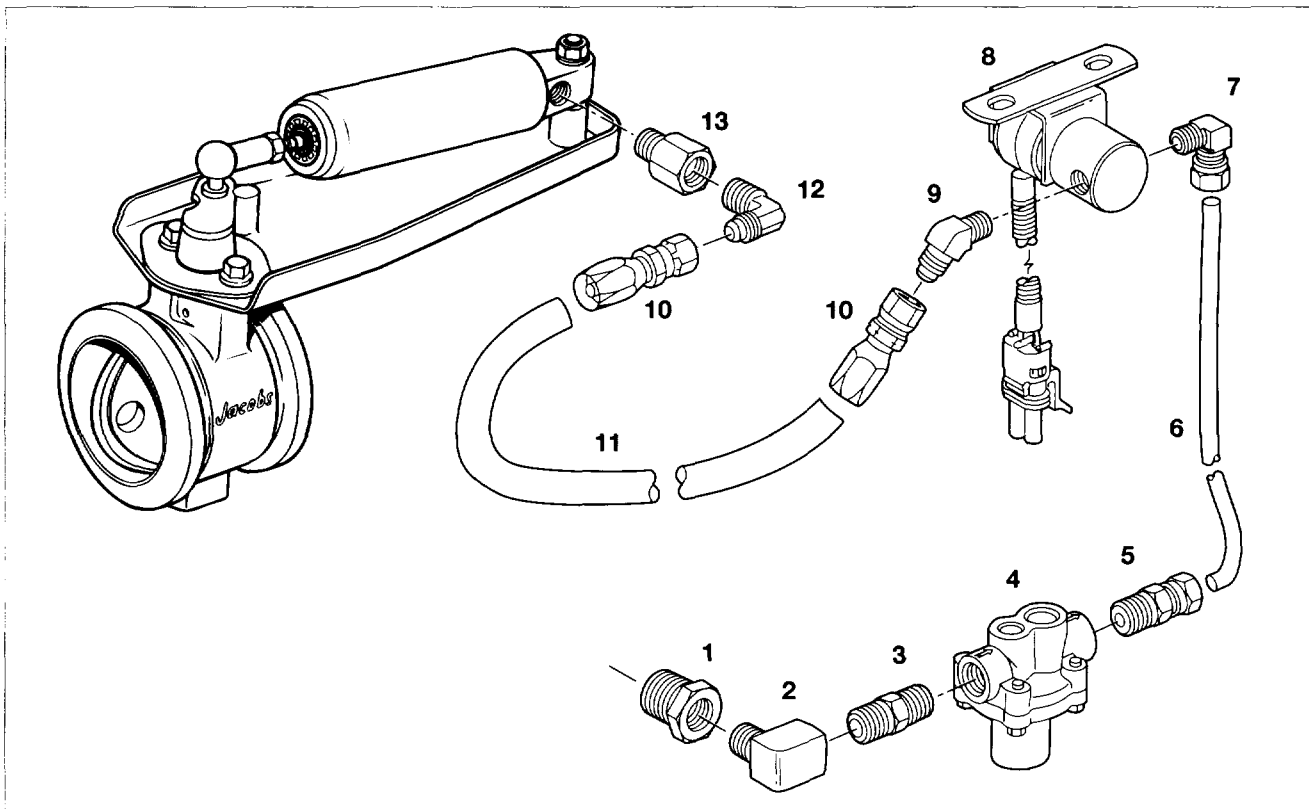

III. Nro.	Número de Pieza	Descripción	Ctd./ Grupo	III. Nro.	Número de Pieza	Descripción	Ctd./ Grupo
1	NVS	Buje	1	10	NVS	Conjunto de guarnición de manguera	2
2	NVS	Codo de macho y hembra de 90°, 1/4 NPT	1	11	NVS	Manguera de freno neumático	1
3	NVS	Niple hexagonal	1	12	NVS	Codo de 45°, abocinado 90°, 1/4 NPT	1
4	J18908	Válvula de protección	1	13	NVS	Adaptador	1
5	NVS	Conjunto de guarnición de compresión	1	NI	NVS	Abrazadera de apoyo	5
6	NVS	Tubo de freno neumático	1	NI	NVS	Perno hexagonal de 1/4 - 20 x 1	5
7	NVS	Conjunto de guarnición de compresión	1	NI	NVS	Tuerca hexagonal de 1/4 - 20	5
8	J19304	Conjunto de válvula solenoide	1	NI	NVS	Arandela sencilla	5
9	NVS	Codo de 45°, abocinado 45°, 1/8 NPT	1	NI	NVS	Arandela de presión	5

NI - No ilustrada

NVS = No se vende separadamente



### Engine Control Group (NSS)

III. Part	No.	Description	Qty./	Group
1	1	Switch	1	
2	1	Clamp	1	
3	2	Screw	2	
4	2	Plain washer	2	
5	2	Lock washer	2	
6	2	Quick disconnect tab	2	
7	1	Diode assembly	1	
8	2	Screw assembly	2	
9	2	Hex cap bolt, M6 x 1.20	2	
10	2	Plain washer, 6 mm	2	
11	2	Lock washer, 6 mm	2	
12	1	Bracket	1	

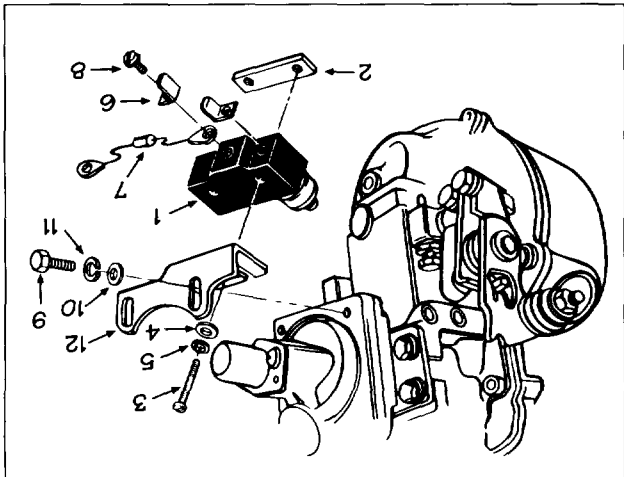

### Clutch Switch Group, P/N J12261

III. No.	Description	Qty./	Group
1	Clutch switch	1	
2	Switch mount bracket	1	
3	Pan head screw	2	
4	Lock washer	2	
5	Hex nut	2	
6	Butt splice	2	
NI	Instruction sheet	1	

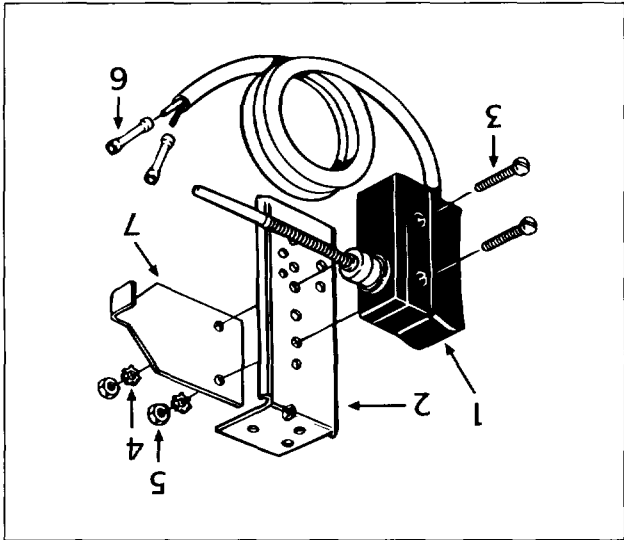

### Dash Switch Group, NSS

III. No.	Description	Qty./	Group
NI	Dash switch	1	
NI	Switch plate (English)	1	
NI	Switch plate (Spanish)	1	
NI	Dashboard decal (Eng.)	1	
NI	Dashboard decal (Span.)	1	

### Wire Harness (NI), P/N J18899

NI = Not illustrated  
NSS = Not sold separately

## Application Notes

Information in this manual was current at the time of printing and is subject to change without notice or liability.

Vehicles equipped with hydraulic brakes may not have an on-board air supply. Vehicles without an on-board air supply require the installation of an auxiliary air supply system. For these vehicles, order Pneumatic Group with Air Supply, P/N J19482. Refer to the instructions in this group for parts and installation information.

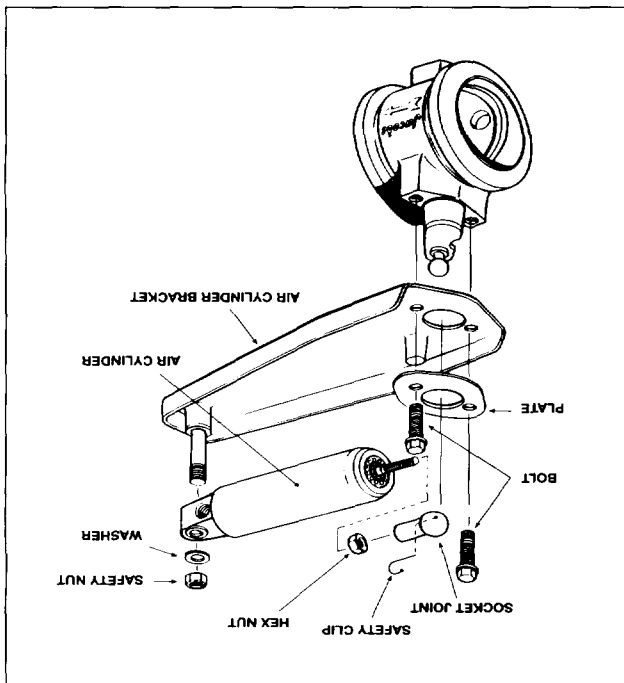

Exploded view of exhaust brake assembly

## Exhaust Brake Assembly and Attaching Parts

Ill. No.	Part Number	Description	Qty./Engine
1	2015983C1	Gasket	2
2	NSS	Turbo pipe	1
3	NSS	"V" clamp	3
4	NSS	Exhaust pipe	1
5	690695C91	Model EX466A-C brake assy.1	1

## Engine Conversion Parts Group, P/N 1821043C91

NSS	NSS	Rocker arm	12
NSS	NSS	Valve spring lock	24
NSS	NSS	Rotator assembly	6
NSS	NSS	Exhaust valve spring	6
NSS	NSS	Valve cover gasket	1
NSS	NSS	Valve cover grommet	6
NSS	NSS	Instructions	1

NI = Not Illustrated  
NSS = Not sold separately

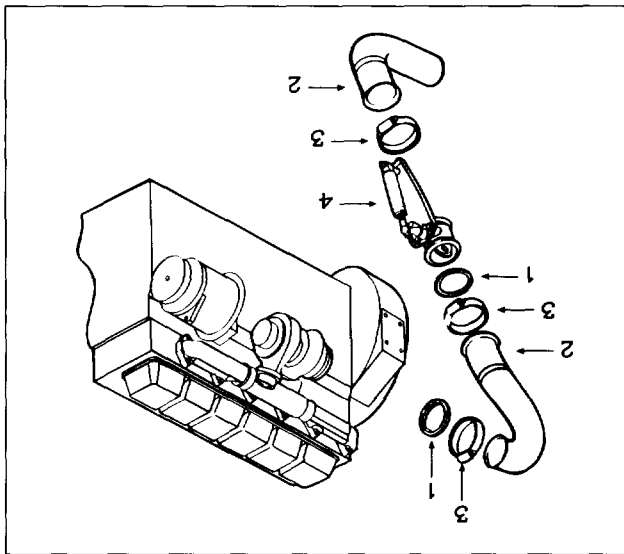

Jacobs Vehicle Systems  
22 East Dudley Town Road  
Bloomfield, CT 06002



Jacobs Vehicle Systems™

Visit us on the Internet:  
www.jakebrake.com

Printed in U.S.A.

©1998 Jacobs Vehicle Systems, Inc.

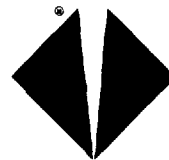

**INTERNATIONAL**

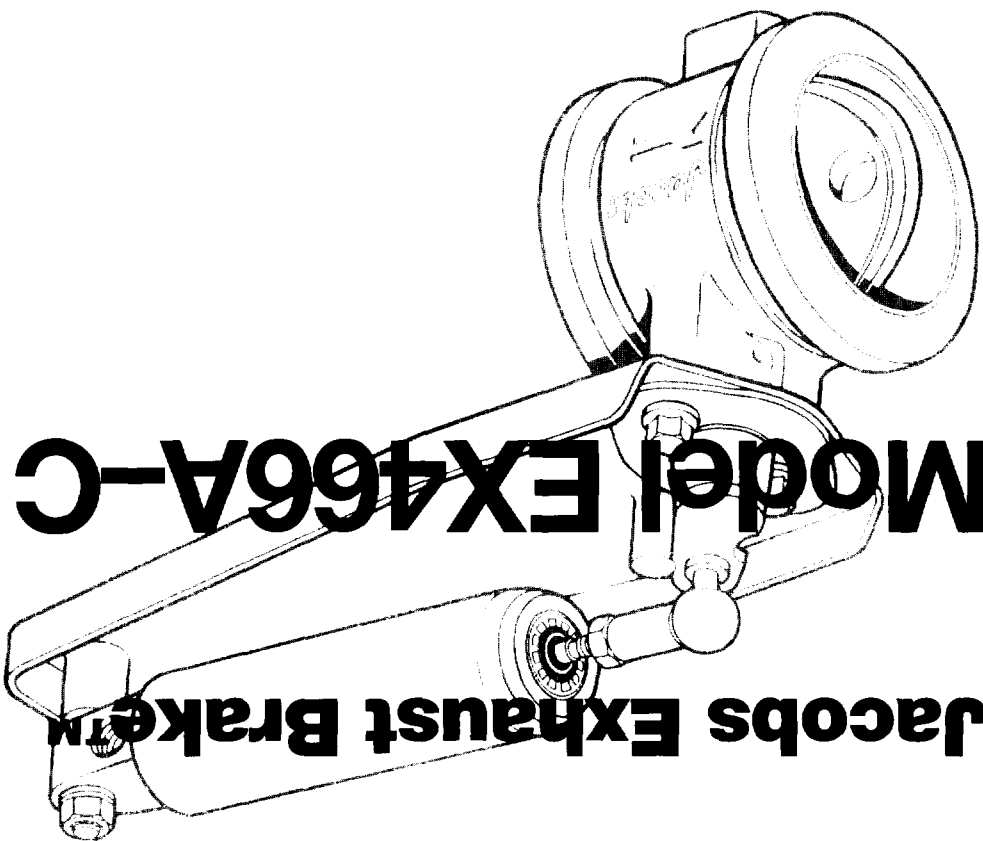

**Model EX466A-C**

**Jacobs Exhaust Brake**



**Jacobs Vehicle Systems™**

# PARTS MANUAL