

# Jake Brake® Update Kit

Model C317A to

Model 317C

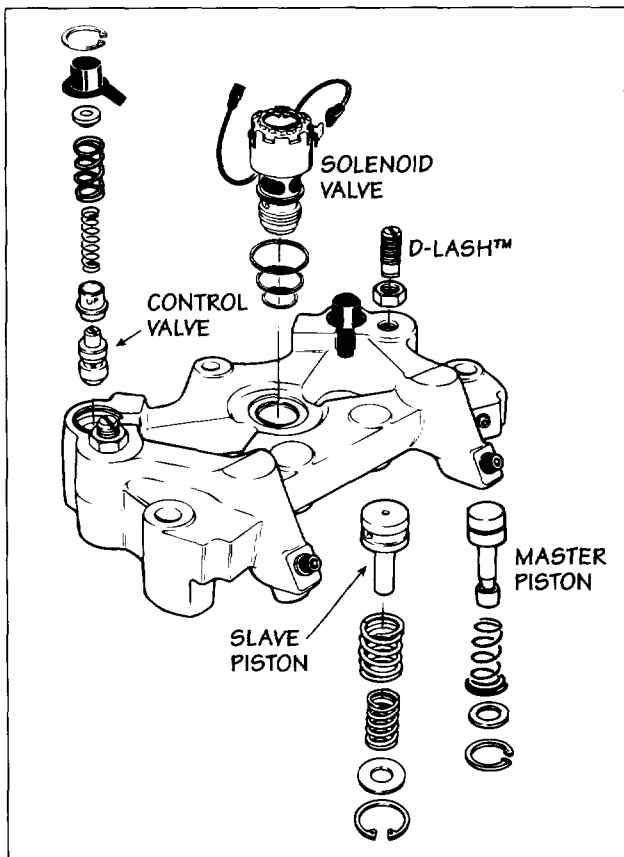

FIG. 1

## Update Kit, P/N 020641

P/N	Part Name	Quantity/ Kit
011251	Control valve collar	6
011252	Control valve cover	6
011283	Control valve	6
011284	Retaining ring	6
014619	Harness	3
015906	Seal	3
01-016440	Solenoid (contains seals)	3
018697	Control valve cover insert	6
019190	Control valve outer spring	6
019504	Control valve inner spring	6
020557	Master piston group	1
020643	ID plate	1
020649	Adhesive kit	1
021492	D-Lash™ assembly (6-pack)	1

## Introduction

### Recommended Torque Values

Jacobs Parts	Lb.-ft.	N•m
Cylinder head bolt	203	275
Cylinder head bolt spacers	65	88
Brake mounting stud assembly	70	95
Housing hold down nuts	59	80
Housing bolts, 190 mm	70	95
Housing bolts, 70 mm	41	55
Slave piston adjusting screw locknut	25	35
Spacer bolts (cover)	9	12
Solenoid valve	9	12

Caterpillar Parts	Lb.-ft.	N•m
Valve bridge adjusting screw locknut	18	25
Ex. rocker arm adjusting screw locknut	18	25
Injector rocker arm adjusting screw	41	55

## 317C Application and Adjustment

Engine	Model Year	Serial Number	Horsepower	Slave Lash
3176	1992	7LG07500 and greater	325 - 350	0.020"



# Update Instructions

These instructions describe how to properly remove, clean and reinstall engine brake components. Use an OSHA-approved cleaning solvent when washing parts. Be sure to coat parts with clean engine oil when reinstalling them.



**NEVER REMOVE ANY ENGINE BRAKE COMPONENT WITH THE ENGINE RUNNING. PERSONAL INJURY MAY RESULT.**

## Solenoid Valve



**DO NOT DISASSEMBLE OR TAMPER WITH THE SOLENOID VALVE. ENGINE DAMAGE COULD RESULT. THE SOLENOID VALVE IS NOT FIELD SERVICEABLE.**

1. Disconnect the solenoid harness. Using a 7/8" socket and extension, unscrew the solenoid valve.
2. Remove and discard the three solenoid valves and three rubber seals per solenoid valve. If the lower ring stays in the bottom of the housing solenoid bore, remove it with a seal pick.
3. Clean out the solenoid valve bore in the housing. Use clean paper towels. Never use rags, as they may leave lint and residue which can plug the oil passageways.
4. Coat the new solenoid seal rings with clean lube oil. Install the upper (A, Fig. 2) and center (B) seal rings on the solenoid body and the lower (C) seal ring into the bottom of the solenoid bore in the housing.
5. Be sure the seals are seated properly. Carefully screw the solenoid into the housing without unseating the seals. Torque the solenoid valve to 9 lb.-ft. (12 N•m). Be careful not to twist the seals while installing.

## Control Valve



**THE CONTROL VALVE COVERS ARE UNDER LOAD FROM THE CONTROL VALVE SPRINGS. BE SURE TO REMOVE THE CONTROL VALVE COVERS CAREFULLY TO AVOID PERSONAL INJURY.**

1. Apply pressure on the control valve cover and rotate the retaining ring ears to the slot in the housing (see Fig. 3). Remove the retaining ring using retaining ring pliers.

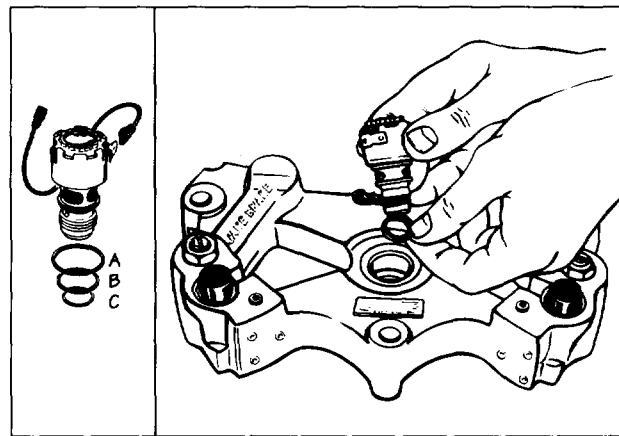

FIG. 2

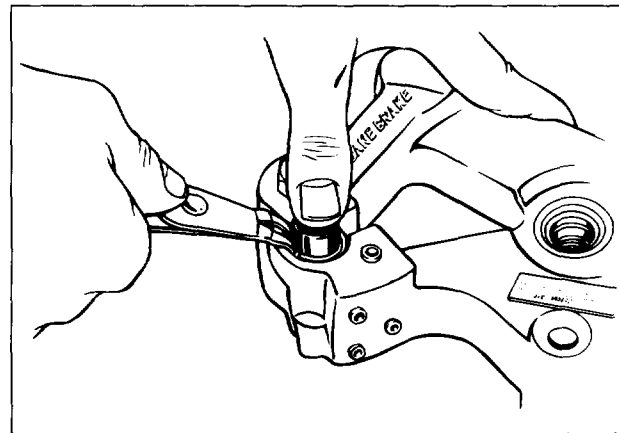

FIG. 3

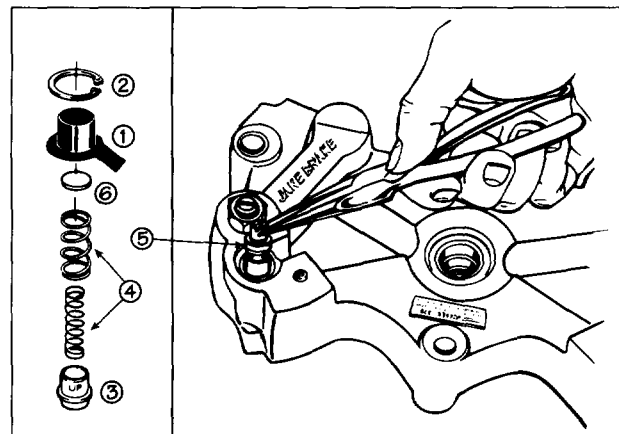

FIG. 4

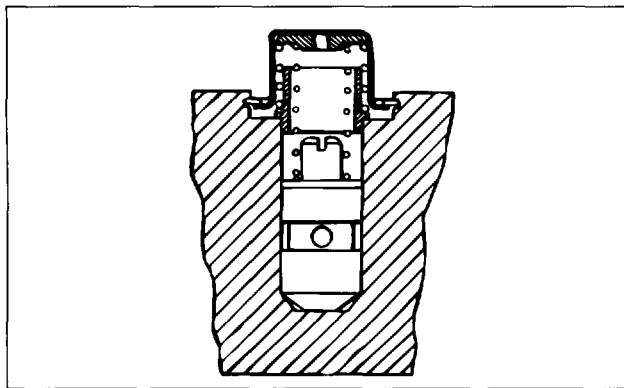

FIG. 5

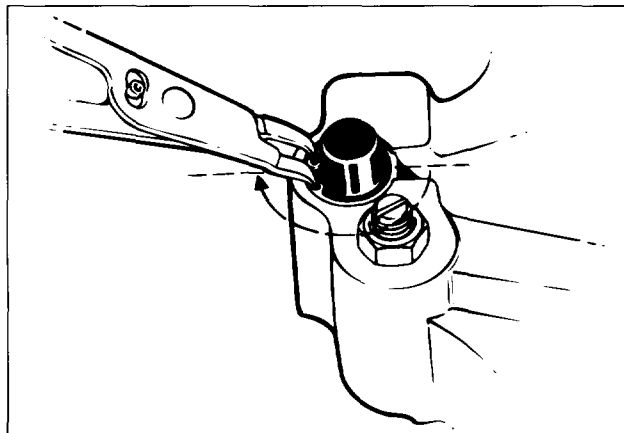

FIG. 6

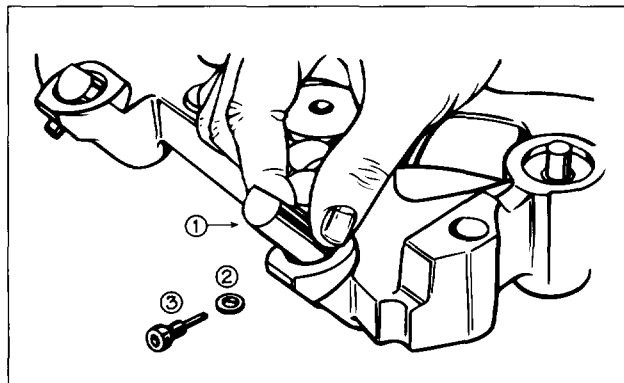

FIG. 7

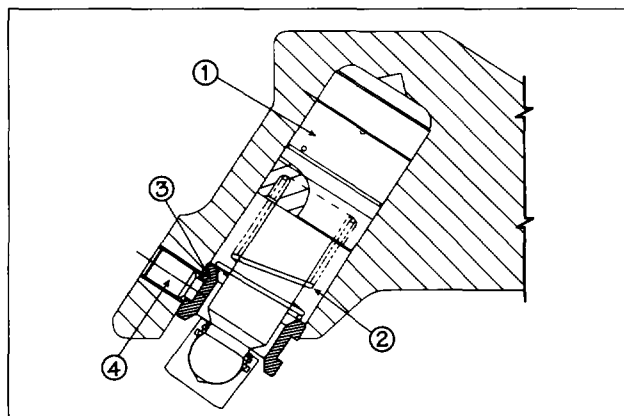
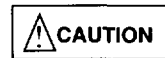

FIG. 8

2. Slowly remove the cover until spring pressure ceases, then remove the two control valve springs (see 4, Fig. 4), insert (6) and collar (3).
3. Using needle-nose pliers, reach into the bore and grasp the stem of the control valve (5). Remove the control valve.
4. Discard all parts and replace them with new parts from the Update Kit.
5. Thoroughly clean the control valve bore in the housing using clean paper towels.
6. Reassemble the parts, reversing the removal procedure.



**BE SURE THE CONTROL VALVE COLLAR IS INSTALLED WITH THE LONGER SLEEVE AREA UP (SEE FIG. 5). IF THE COLLAR IS INSTALLED UPSIDE DOWN, ENGINE DAMAGE MAY RESULT.**

7. Rotate the retaining ring so that the ears are located away from the slot in the housing as shown in Fig. 6.

## Master Piston

1. Remove the anti-rotation pin assembly (3, Fig. 7) and lock washer (2) from the housing and discard.
2. Remove the master piston assembly (1).
3. Install the new master piston assembly (1, Fig. 8) and master piston return spring (2). Be sure to put the tapered master piston return spring into the bore with the small end toward the bottom of the bore (inside the master piston recess).
4. Install the sleeve (3, Fig. 8) into the master piston bore so that it sits on the shoulder above the 0.750" diameter counterbore. Verify that the sleeve is seated by looking through the anti-rotation pin hole in the housing and making sure that the sleeve annulus is centered in the hole. If the sleeve is not seated, tap on it lightly with a hammer until it is in place.
5. Install the set screw (4, Fig. 8) while holding the sleeve in place. Torque to 10 lb.-in.
6. Ensure proper seating by pulling each master piston out of its bore until it contacts the sleeve. Recheck the set screw torque.
7. When all six (6) pistons have been installed, install the brake housings on the engine as instructed in the Installation Manual.

## Slave Piston Adjusting Screw

1. Loosen the slave piston adjusting screw locknut and remove the adjusting screw from the housing (see Fig. 9).

**NOTE:**

**THE PART NUMBER FOR THE SCREW IS LOCATED AT THE TOP OF THE SCREW NEXT TO THE SCREWDRIVER SLOT.**



**DO NOT ADJUST OR TAMPER WITH THE ADJUSTING SCREW ASSEMBLY. ENGINE DAMAGE COULD RESULT.**

2. Remove the locknut from the screw. Remove and discard the slave piston adjusting screw. Replace it with the D-Lash™ assembly included in the Update Kit, using the old locknut. Be sure to set the proper slave piston lash for the engine (see Page 1).

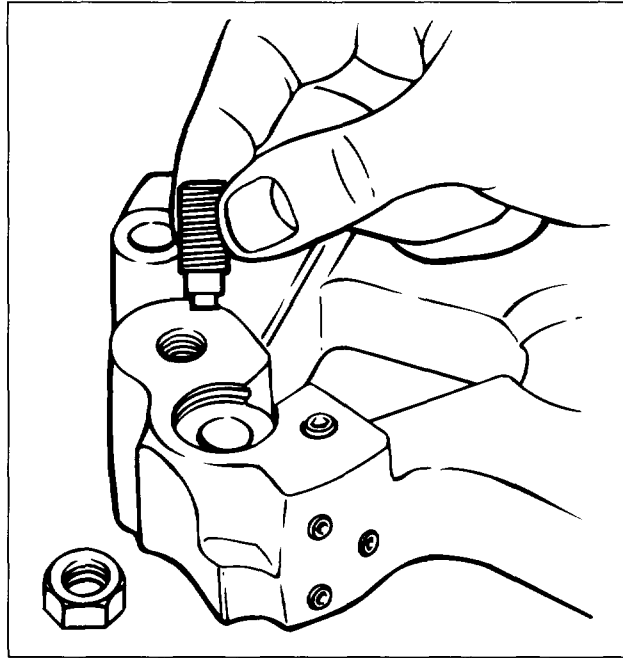

FIG. 9

## Nameplate

1. Gently pry the old nameplate until it starts to loosen.
2. Grab the rivets with vice grips and pull up to remove.
3. Follow the instructions contained in the Adhesive Kit and apply the new nameplate to the housing.

**Jacobs®**

.....  
Jacobs® and Jake Brake® are registered trademarks and D-Lash™ is a trademark of Jacobs Vehicle Equipment Company  
22 East Dudley Town Road • Bloomfield CT 06002

© 1995 Jacobs Vehicle Equipment Company  
Printed in USA 11/95 P/N 020646