

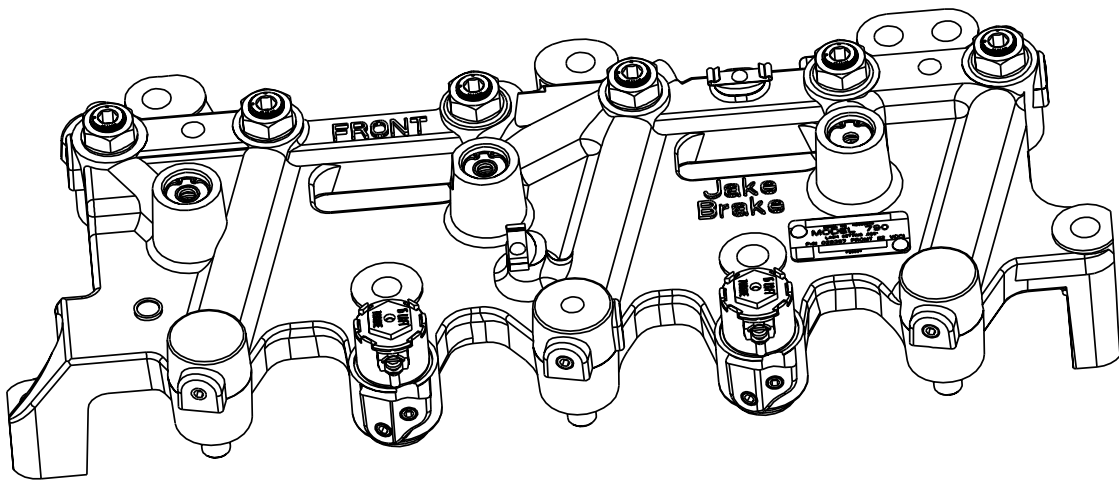

Jacobs Vehicle Systems®

Jacobs Engine Brake®

Tune-Up Kit ***790/795 Series*** ***P/N 29013***



Information in this manual was current at time of printing and is subject to change without notice or liability.

Refer to the Application guide, P/N 24770 for specific application information. Also refer to the Install Manual, P/N 29901 and the engine manual for specific installation instructions.

TUNE-UP KIT INSTRUCTIONS

Tune-up Kit Contents

Illus. No.	P/N	Part Name	Quantity per kit	Illus. No.	P/N	Part Name	Quantity per kit																				
1	1024612	Solenoid, 12VDC S/L	0	11	26142	Slave Piston	0																				
1	1024619	Solenoid, 24VDC S/L	0	12	28379	Bridge, Slave Piston	0																				
2	20229	Seal, Solenoid Upper	3	13	28372	Spring, Inner Slave Piston	6																				
3	1082	Seal, Solenoid Center	3	14	28373	Spring, Outer Slave Piston	6																				
4	26932	Master Piston	6	15	29295	Bolt, Shoulder - Slave Piston	6																				
5	28791	Push Rod, Master Piston	0	16	12991	Ring, Retainer	6																				
6	28768	Spring, Master Piston	6	17	16505	Washer	6																				
7	29944	Retainer, Master Piston	6	18	18179	Spring, Inner Control Valve	6																				
8	26555	Ring, Retainer	6	19	10843	Spring, Outer Control Valve	6																				
9	19987	Nut, Hex (790, 790A, 790B, 790C)	0	20	11930	Control Valve	6																				
9	29908	Nut, Hex (795)	0	21	18485	Pipe Plug	0																				
10	28375	J-lash™ assembly (790)	0	22	17303	Drive Screw	0																				
10	29300	J-lash™ assembly (790A)	0	23	29127	Clip, Wire Harness	0																				
10	29317	J-lash™ assembly (790B)	0	24	28346	CapScrew, M12X1.75X170	0																				
10	29310	J-lash™ assembly (790C)	0 </tr <tr> <td>10</td> <td>29864</td> <td>Solid Screw, 3/8-24 (795)</td> <td>0</td> <td>25</td> <td>29132</td> <td>CapScrew, M12X1.75X140</td> <td>0</td> </tr> <tr> <td></td> <td></td> <td></td> <td></td> <td>26</td> <td>29118</td> <td>Spacer Tube</td> <td>0</td> </tr> <tr> <td></td> <td></td> <td></td> <td></td> <td>NI</td> <td>29015</td> <td>Instructions</td> <td>1</td> </tr>	10	29864	Solid Screw, 3/8-24 (795)	0	25	29132	CapScrew, M12X1.75X140	0					26	29118	Spacer Tube	0					NI	29015	Instructions	1
10	29864	Solid Screw, 3/8-24 (795)	0	25	29132	CapScrew, M12X1.75X140	0																				
				26	29118	Spacer Tube	0																				
				NI	29015	Instructions	1																				

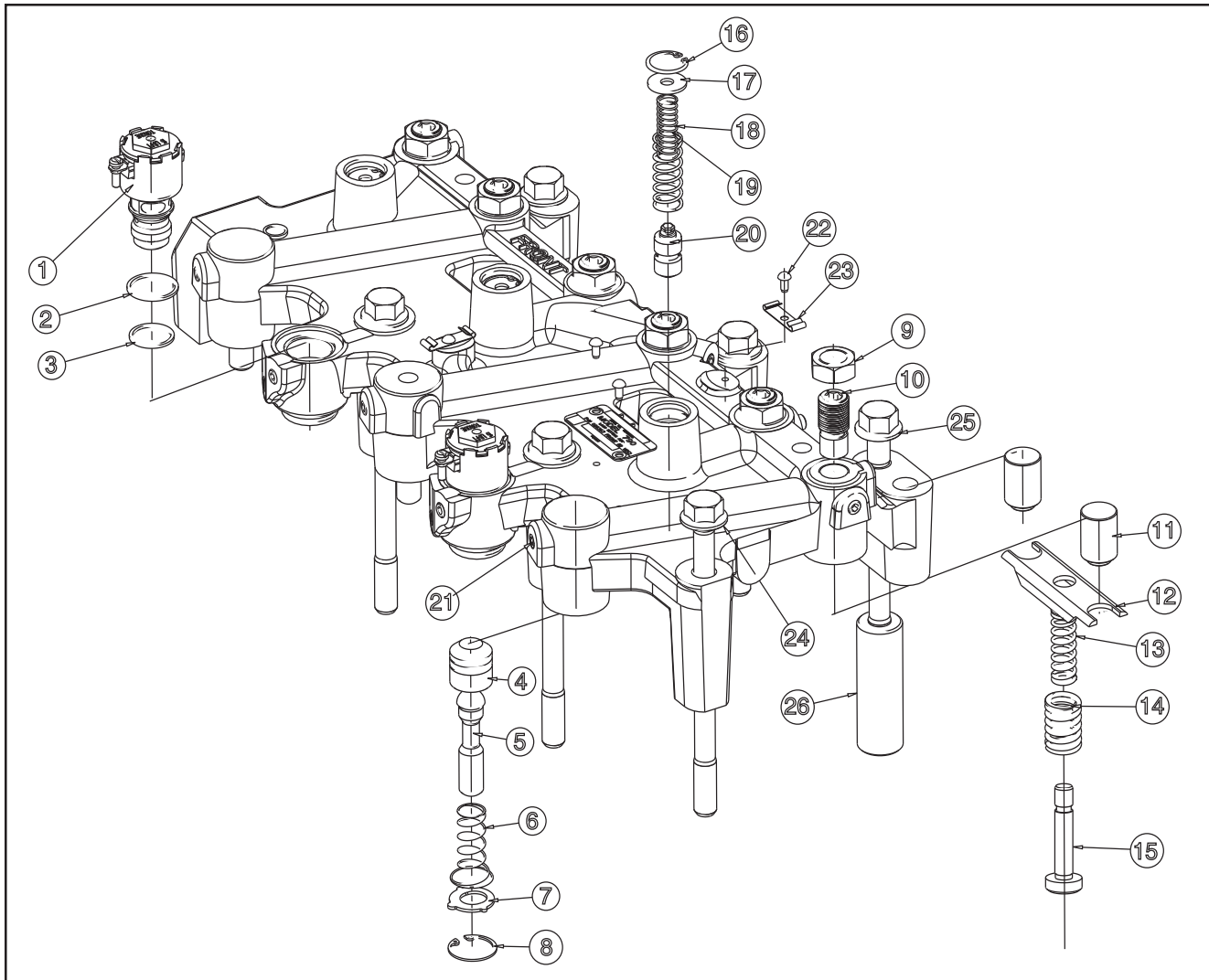

General Information

These instructions describe how to properly remove, clean and reinstall Jacobs Engine Brake® components. For additional information on the 790/795 Series engine brakes, refer to the Series 60 Engine Service Manual, P/N 6SE483.

The slave piston clearance settings listed on page 5 of this manual are current as of this printing, for updated settings refer to the Jacobs Engine Brake for Detroit Diesel Engines Application Guide, P/N 24770.

Use OSHA-approved cleaning solvent for cleaning parts. Original parts to be reused should be inspected for wear and replaced as required. Be sure to coat parts with clean engine oil when reinstalling them.

The standard Jacobs Vehicle Systems Service Parts Warranty applies to the components of this Tune-up Kit. The warranty is administered by Detroit Diesel Corporation.

Safety Precautions

The following symbols in this manual signal conditions potentially dangerous to the mechanic or equipment. Read this manual carefully. Know when these conditions can exist. Then take necessary steps to protect personnel as well as equipment.

 **WARNING** THIS SYMBOL WARNS OF POSSIBLE PERSONAL INJURY.

 **CAUTION** THIS SYMBOL REFERS TO POSSIBLE EQUIPMENT DAMAGE.

NOTE: INDICATES AN OPERATION, PROCEDURE OR INSTRUCTION THAT IS IMPORTANT FOR CORRECT SERVICE.

Fuels, electrical equipment, exhaust gases and moving engine parts present potential hazards that could result in personal injury. Take care when installing equipment or parts. Always wear safety glasses. Always use correct tools and follow proper procedures as outlined in this manual.

Instructions

 **WARNING** NEVER REMOVE OR ADJUST ANY ENGINE BRAKE OR COMPONENT WITH THE ENGINE RUNNING.

Access Engine Brake

1. Thoroughly clean engine.
2. Remove valve rocker cover and gasket.

NOTE: IF THE ENGINE HAS A TWO-PIECE COVER, THE LOWER VALVE COVER BASE DOES NOT HAVE TO BE REMOVED TO GAIN ACCESS TO THE ENGINE BRAKE HOUSINGS.

3. Disconnect the lead wires from each of the solenoid valves (1) and detach them from the wire clips (23).
4. Remove the six capscrews (24&25) and nut securing each engine brake housing. Remove the housings.
5. Retain six spacer tubes (26).

Disassemble Housings

1. Remove the solenoid valve (1) and discard all the seal rings (2,3).

 **WARNING** WEAR SAFETY GLASSES. REMOVE CONTROL VALVE COVERS CAREFULLY TO AVOID PERSONAL INJURY. COVERS ARE UNDER LOAD FROM CONTROL VALVE SPRINGS (18,19).

2. Hold down the control valve cover while removing the retaining ring (16). Remove and discard all parts.
3. Loosen the locknuts (9) and remove the adjusting screws (10) and locknuts. Retain the adjusting screws and locknuts.
4. Remove the retaining rings (8), retainers (7), springs (6), push rods (5) and master pistons (4). Discard the springs, retainers, retaining rings, and master pistons. Retain push rods for reassembly.
5. Remove the shoulder bolt (15) and springs (14,13) that retain the slave piston; discard these parts. Remove and save the bridge (12) and slave piston (11).

Assemble Housings

1. Clean all parts in an approved cleaning solvent. Dry with compressed air.
2. Coat all parts to be installed into housings with clean lube oil.
3. Reinstall the original slave piston (11) and bridge (12), reversing the removal procedure.
4. Install the new shoulder bolt (15) and springs (13,14). Tighten the bolt to 23 N•m (200 lb-in).
5. Install the new master piston (4) and reinstall the push rod (5). Install the new spring (6), retainer (7) and retaining ring (8). Rotate the retaining ring 90° to ensure that the ring is seated in the groove.
6. Install the adjusting screw (10) and locknut (9). Do not tighten the locknut at this time.
7. Install the new control valve (20), springs (18, 19), cover (17) and retaining ring (16). Rotate the retaining ring 90° to ensure that the ring is seated in the groove.
8. Install the upper (2) and center (3) seal rings on the solenoid valve. Coat the seals with engine oil prior to assembly.

NOTE: NEW UPPER SEAL RINGS CAN BE IDENTIFIED BY A YELLOW STRIPE.

9. Insert the solenoid valve and torque to 20 N•m (15 lb-ft).

NOTE: INSTALL THE SOLENOID CAREFULLY TO AVOID CUTTING OR TWISTING THE SEAL RINGS. IMPROPER INSTALLATION COULD RESULT IN POOR ENGINE BRAKE PERFORMANCE.

1. Place the engine brake housings on the rocker shafts and spacer tubes with the solenoids on the camshaft side of the engine and the slave pistons over the exhaust valves.
2. Lubricate each hold-down bolt with clean engine oil prior to installation.
3. Install three M12x170 bolts (24) on solenoid side of brake. Install three M12x140 bolts (25) on the exhaust side of the engine.



INSTALLING 170 MM BOLTS (24) ON THE EXHAUST SIDE OF THE ENGINE CAN RESULT IN SERIOUS ENGINE DAMAGE.

4. Before tightening the capscrews, move the housing from side to side. Position housing in the center of the range of motion.
5. Tighten the capscrews in the following sequence:
 - a. Starting with the middle bolt, tighten the three bolts on the camshaft side of the engine to 55 N•m (40 lb-ft).
 - b. Starting with the middle bolt, tighten the three bolts on the exhaust manifold side of the engine to 55 N•m (40 lb-ft).
 - c. Tighten the nut at the end of the rocker shaft to 55 N•m (40 lb-ft)
 - d. Repeat the tightening sequence and torque all capscrews to 136 N•m (100 lb-ft).
 - e. Follow the same sequence for the other brake.
6. Connect the lead wires to the solenoid valves passing the wires through the wire clips. Torque to 1 N•m (9 lb-ft) and pull the lead wires away from the housing.

Install Engine Brake Housings

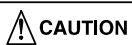

REMOVING THE OIL FROM THE BOLT HOLES PREVENTS THE CYLINDER HEAD FROM CRACKING WHEN BOLTS ARE TIGHTENED. ATTACH A LENGTH OF TUBING TO AN AIR GUN NOZZLE AND BLOW OUT THE OIL FROM THE HOUSING HOLD-DOWN BOLT HOLES. COVER THE HOLES WITH HAND TOWELS TO MINIMIZE OIL SPRAY.



WEAR SAFETY GLASSES WHILE BLOWING THE OIL FROM THE BOLT HOLES.

Adjust Slave Piston Clearance

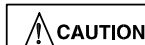

FAILURE TO FOLLOW ADJUSTMENT PROCEDURES CAN RESULT IN ENGINE OR ENGINE BRAKE DAMAGE.

NOTE: MAKE SLAVE PISTON ADJUSTMENT WITH THE ENGINE STOPPED AND COLD. ADJUST EACH CYLINDER WITH THE EXHAUST VALVES IN THE CLOSED POSITION.

1. Back out the adjusting screw on the slave piston until the slave piston does not touch the rocker arm.
2. Insert the proper feeler gage between the slave piston and the exhaust rocker adjusting screw. Using a hex wrench, turn in the adjusting screw until the slave piston contacts the exhaust rocker adjusting screw through the feeler gage. For Model 795 applications, skip to step 4. For J-Lash installation only, continue turning in the adjusting screw until the valve springs begin to compress, then turn in one (1) additional turn. Wait at least 30 seconds for oil to be purged from the J-Lash adjusting screw.

NOTE: ALL OIL MUST BE PURGED FROM THE J-LASH ADJUSTING SCREW. IF OIL IS BELOW 60 °F, 16 °C, WAIT AT LEAST TWO MINUTES FOR OIL TO BE PURGED FROM THE J-LASH ADJUSTING SCREW.

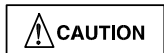

CAUTION SERIOUS ENGINE DAMAGE MAY OCCUR FROM IMPROPER LASH SETTING.

3. After the time interval specified in step (2), back out the adjusting screw ONLY until a light drag is felt on the feeler gage. Do not retract more than required to obtain a light drag on the feeler gage. Hold the J-Lash adjusting screw in place and torque the lock nut to 38 N•m (336 lb-in).

NOTE: IF THE J-LASH ADJUSTING SCREW IS BACKED OUT UNTIL IT NO LONGER COMPRESSES THE SLAVE PISTON SPRING, OIL WILL ENTER THE SCREW AND THE ADJUSTMENT WILL BE INCORRECT. IF THIS OCCURS, REPEAT STEPS (1) AND (2).

4. Hold the J-Lash adjusting screw in place and torque the lock nut to 38 N•m (336 lb-in). Recheck lash settings. If lash setting is incorrect, repeat steps (1) through (3) above.

NOTE: ONCE THE ENGINE BRAKE HAS BEEN RUN YOU WILL NOT BE ABLE TO CHECK THE ENGINE BRAKE ADJUSTMENT. THIS IS BECAUSE OF OIL RETAINED IN THE J-LASH ADJUSTING SCREW. IF UNSURE OF THE ADJUSTMENT, YOU MUST REPEAT STEPS (1) THROUGH (4) ABOVE.

Engine Brake Operational Check



WARNING WEAR EYE PROTECTION AND DO NOT EXPOSE YOUR FACE OVER THE ENGINE AREA. TAKE PRECAUTIONS TO PREVENT OIL LEAKAGE ONTO THE ENGINE. COVER CONTROL VALVE AREAS SUFFICIENTLY TO PREVENT OIL SPLASH.

Bleed the engine brake housings.

1. Be sure wires are away from moving parts.
2. Start the engine and allow to run for a few minutes.
3. Manually activate the solenoid valve several times to allow the housing to be filled with oil.

NOTE: THE SOLENOID VALVE IS MANUALLY ACTIVATED BY DEPRESSING THE ARMATURE. THE ARMATURE IS LOCATED IN THE CENTER OF THE TOP OF THE SOLENOID.

Check for proper operation.

1. Manually activate the solenoid valve and watch the master piston to be sure it is moving down onto the roller in the injector rocker arm.
2. Watch the slave piston assembly. It should move down to contact the exhaust valve rocker arm adjusting screws.
3. Check each housing to be sure it is functioning.
4. Shut down engine.

Rocker Cover Installation

Rocker Cover Installation

1. Make sure the seal is in place in the rocker cover base and set the cover in place on the cover base.
2. Install the bolt with a flat washer, isolator and limiting sleeve into the cover holes.
3. Tighten the bolts to 14 N•m (10 lb-ft) in the sequence shown in Fig. 1.
4. Torque the bolts to 27 N•m (20 lb-ft).

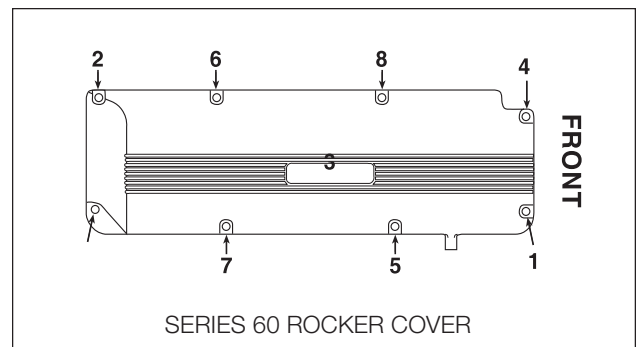

FIG. 1

Jacobs Vehicle Systems
22 East Dudley Town Road
Bloomfield, CT 06002



Jacobs Vehicle Systems

Visit us on the Internet:
www.jacobsvehiclesystems.com

P/N 29015 Rev. B

©2012 Jacobs Vehicle Systems, Inc. Printed in U.S.A.

Rev. 11/12