

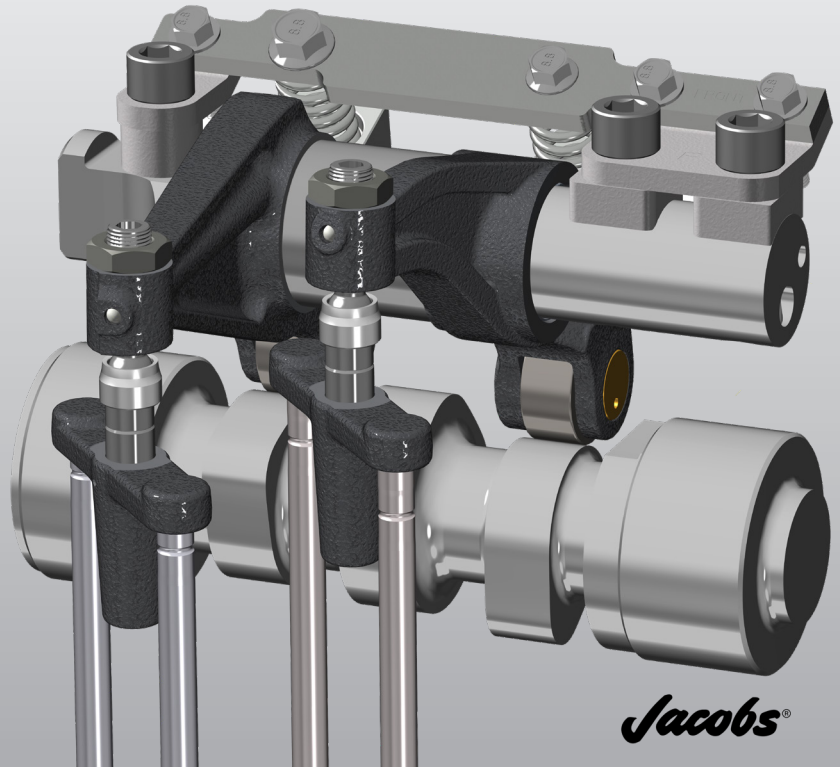

CDA CYLINDER DEACTIVATION



FOR IMPROVED FUEL ECONOMY & EXHAUST THERMAL MANAGEMENT

Cylinder Deactivation leverages Jacobs® well-established componentry to disable engine valves in selected cylinders which allows a large engine to have the fuel economy of a smaller engine. Also, higher exhaust temperatures in operating cylinders maintain aftertreatment temperatures at low load conditions and start-up.

BENEFITS

DURABILITY

Jacobs® CDA hardware has been demonstrated on multiple heavy duty engine platforms and has been road tested on various vehicles. As of early 2022, over 27,000 hours of durability testing have been performed on 20+ heavy-duty engine platforms resulting in over 8 billion cycles on CDA components and over 350,000 km. The systems have also undergone over 470 million cycles of fatigue and overload testing.

BENEFITS

- A key technology for meeting upcoming emissions standards
- Fuel economy improvements through reduced pumping losses and friction
- Faster engine and aftertreatment system warm-up
- Improves combustion and fuel consumption in firing cylinders
- Improves emissions by keeping the aftertreatment system hot during low load operation
- Minimizes cooling of aftertreatment during coasting
- Hydraulically actuated mechanism integrates into pushrod, rocker, or bridge
- Modular with High Power Density® (HPD®) and compression release engine brake technology
- Mechanism is capable of individual cylinder control and dynamically switchable between cylinders
- An optional feature of Jacobs® Lost Motion VVA

BENEFITS

MEETS REGULATORY REQUIREMENTS

Jacobs® cylinder deactivation system has been demonstrated and mentioned by CARB and the EPA to meet upcoming emission targets in combination with an advanced SCR system.

LEARN MORE

Cylinder
Deactivation



LOW LOAD CYCLE RESULTS

Even with a stock 2018 aftertreatment system, Jacobs® CDA system improved SCR conversion efficiency while still lowering overall fuel consumption. Other keep warm strategies will cost more fuel.

CONFIGURATION	BASILINE	CDA 3X3
Number of tests in the average	1	1
Brake work, kW-hr	28.99	29.77
Avg baseline SCR inlet temperature, °C	183	222
SCR NOx conversion efficiency	74%	95%
Tail pipe NOx reduction with CDA	77%	
Tail pipe CO2 reduction with CDA	12%	

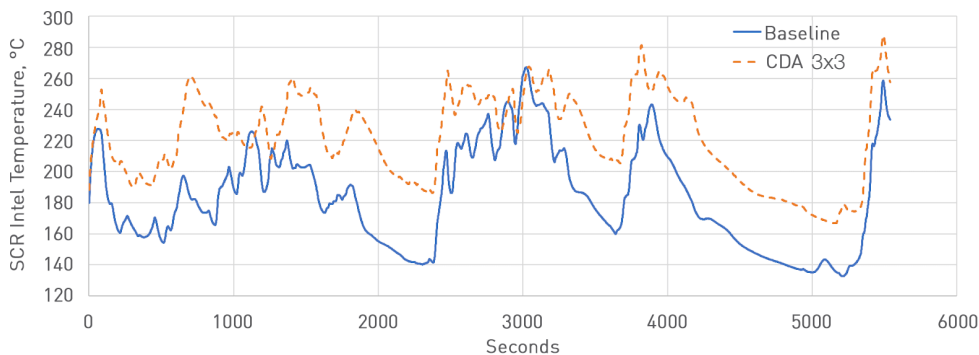

LOW LOAD CYCLE RESULTS

- ▲ +39°C SCR temperature
- ▼ -77% NO_x
- ▼ -12% lower CO₂

Matheaus, A., Singh, J., Sanchez, L., Evans, D. et al., "Evaluation of Cylinder Deactivation on a Class 8 Truck over Light Load Cycles," SAE Technical Paper 2020-01-0800, 2020, <https://doi.org/10.4271/2020-01-0800>

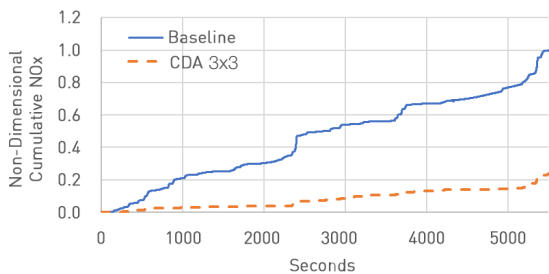

Cummins Inc.
Box 3005
Columbus, IN 47202-3005
U.S.A.

cummins.com

Bulletin 6482467 Produced in U.S.A. 6/23
©2023 Jacobs Vehicle Systems, Inc.