

(B4) RIDE HEIGHT	A (DAMPER LENGTH)	B (LINK LENGTH)
6.5	15.1	4.5
7.5	15.1	5.3
8.0	15.1	5.7
9.0	15.5	5.7
12.0	15.5	6.0
14.0	15.8	7.7
15.0	15.8	8.5
16.0	15.7	6.9
17.0	15.8	7.7
19.0	15.8	9.4

- QUALITY CONTROL CHARACTERISTICS
- (A) DENOTES MAJOR CHARACTERISTIC
  - (D1) SHOCK NUT TORQUE
  - (D2) PIVOT NUT TORQUE PLUS ANGLE

NOTE:  
REFER TO APPROPRIATE 4-60559 LAYOUTS TO OBTAIN AXLE COMPONENT TORQUE VALUES

REVISIONS		
A	RELEASED 4-60559_38 FOR PRODUCTION	117163 GS 27-Oct-11 AJ
B	1-UPDATED VIEWS TO REFLECT THE CHANGES IN RHCY DESIGN 2-TORQUE VALUES FOR PIVOT NUT WAS 100-150 FT-LB 3-ADDED TORQUE 25-35 FT-LB 4-ADDED DIMENSION 'A' & 'B' & RELATED TABLE 5-CHANGED UPPER SHOCK BOLT ORIENTATION	118970 LGS 19-Jun-12 SJP
C	UPDATED VIEWS TO REFLECT THE CHANGES IN RHCY DESIGN 1-CHANGED RHCY LINKAGE BOLT ORIENTATION	119841 LGS 05-Oct-12 SVM
D	D1- REVISED NOTE FOR PIVOT NUT TORQUE D2- ADDED MAJOR CHARACTERISTIC FOR PIVOT NUT PLUS ANGLE	ECN-137447 JMK 02-13-17 VL
E	ADDED MTA23L INFO.	ECN-143200 LGS 04-Oct-17 SKS
F	UPDATED RHCY REPRESENTATION	ECN-167907 VMJ 15-JUN-20 SD
G	REMOVED OPTIONAL TORQUE DETAILS AND UPDATED TORQUE INFORMATION TO TORQUE PLUS ANGLE ONLY	ECN-187308 EN 16-MAR-22 MKV

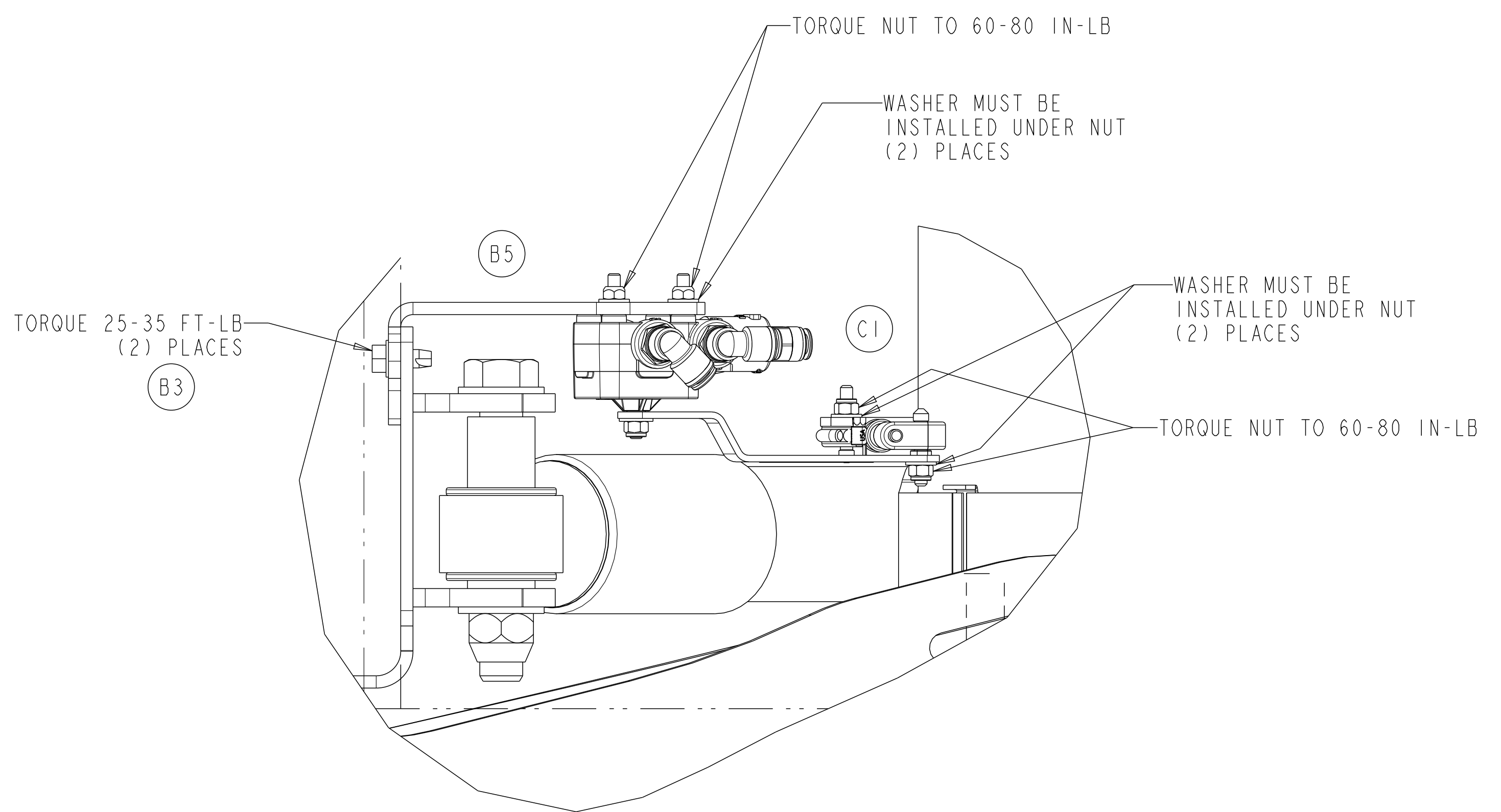
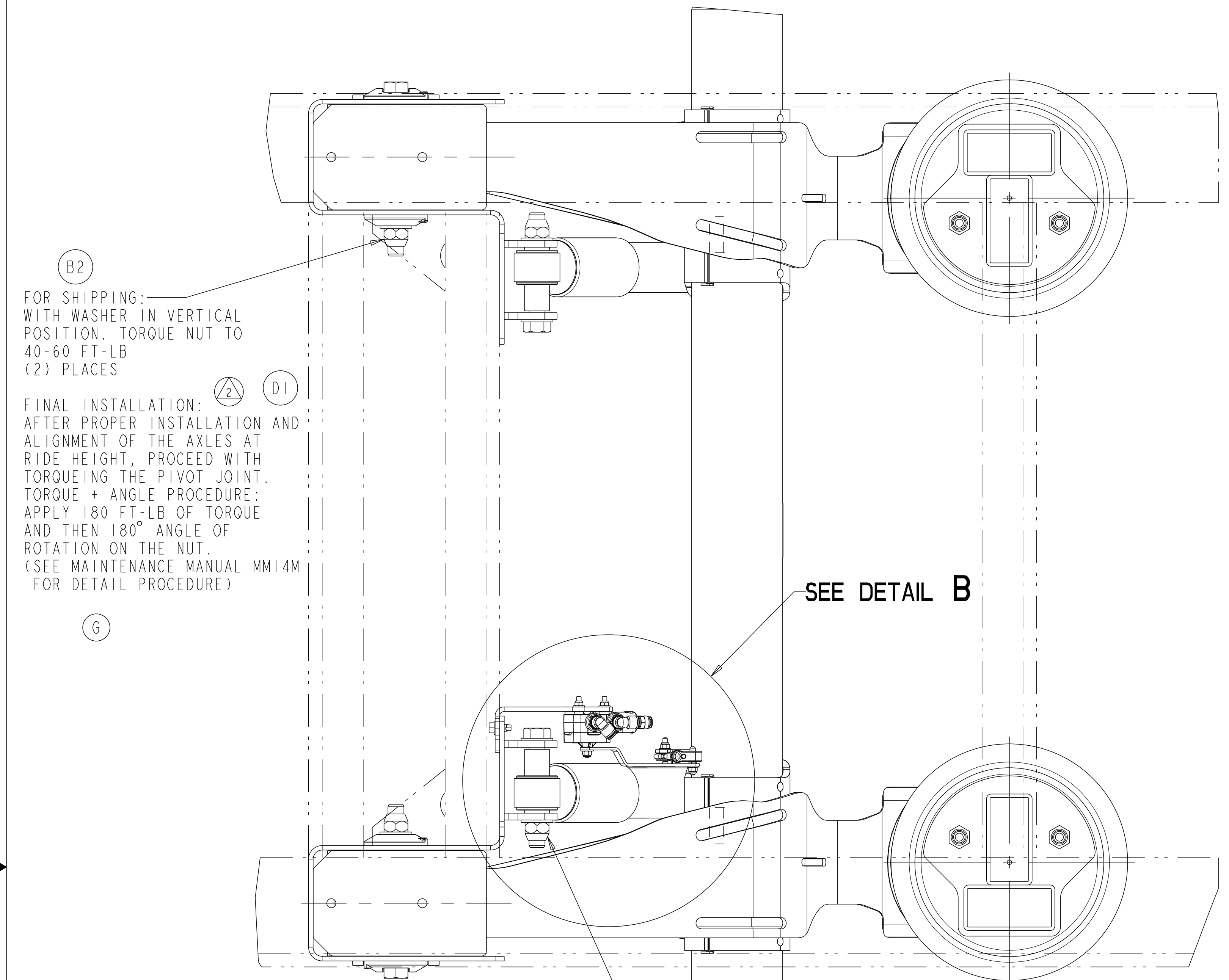

DETAIL B  
SCALE 1:2

CAD FILES		
FILE NAME	REV. VER	
DRAWING 4-60559.38	6.2	
ASSEM 4-60559.38	6.2	

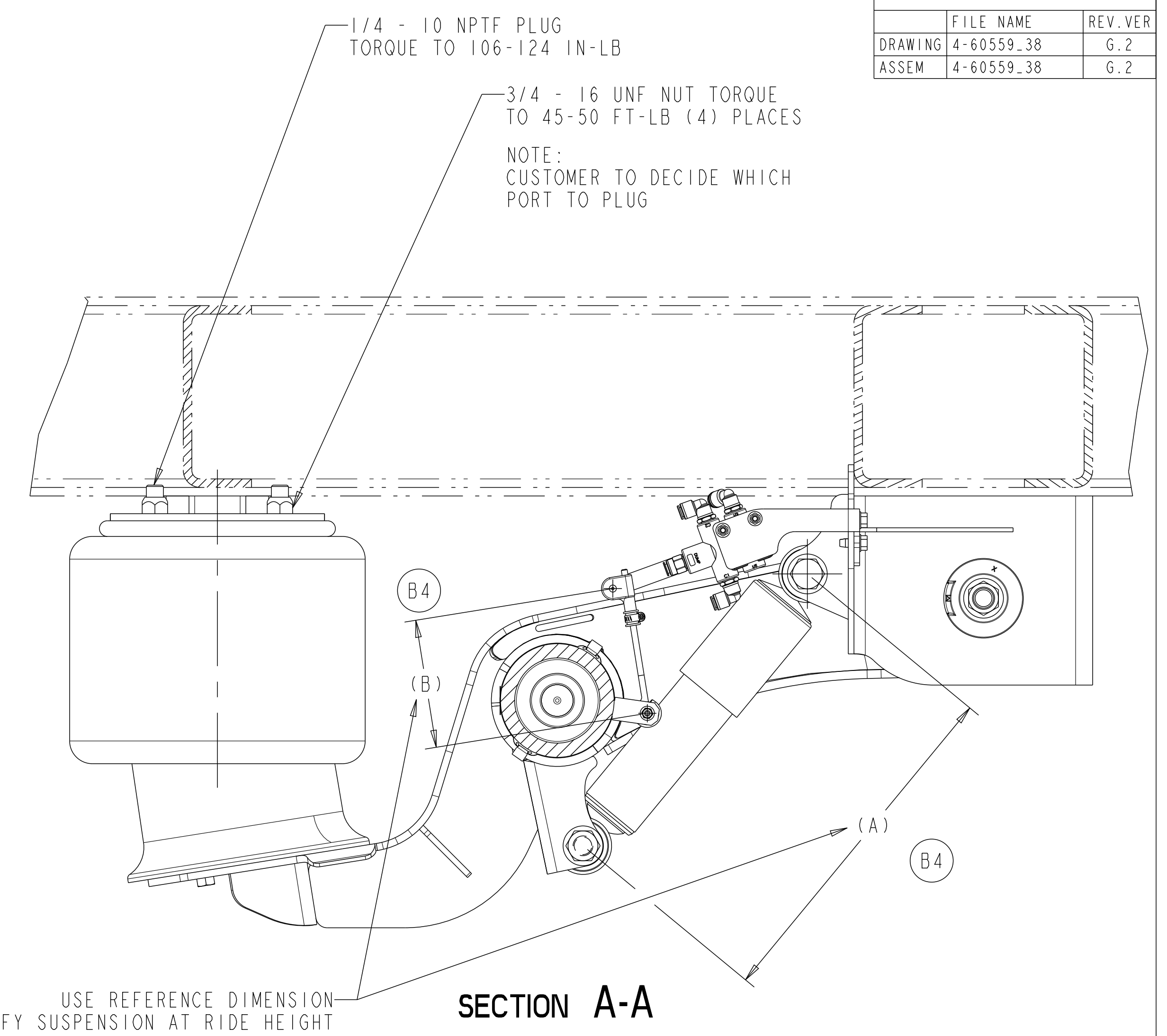
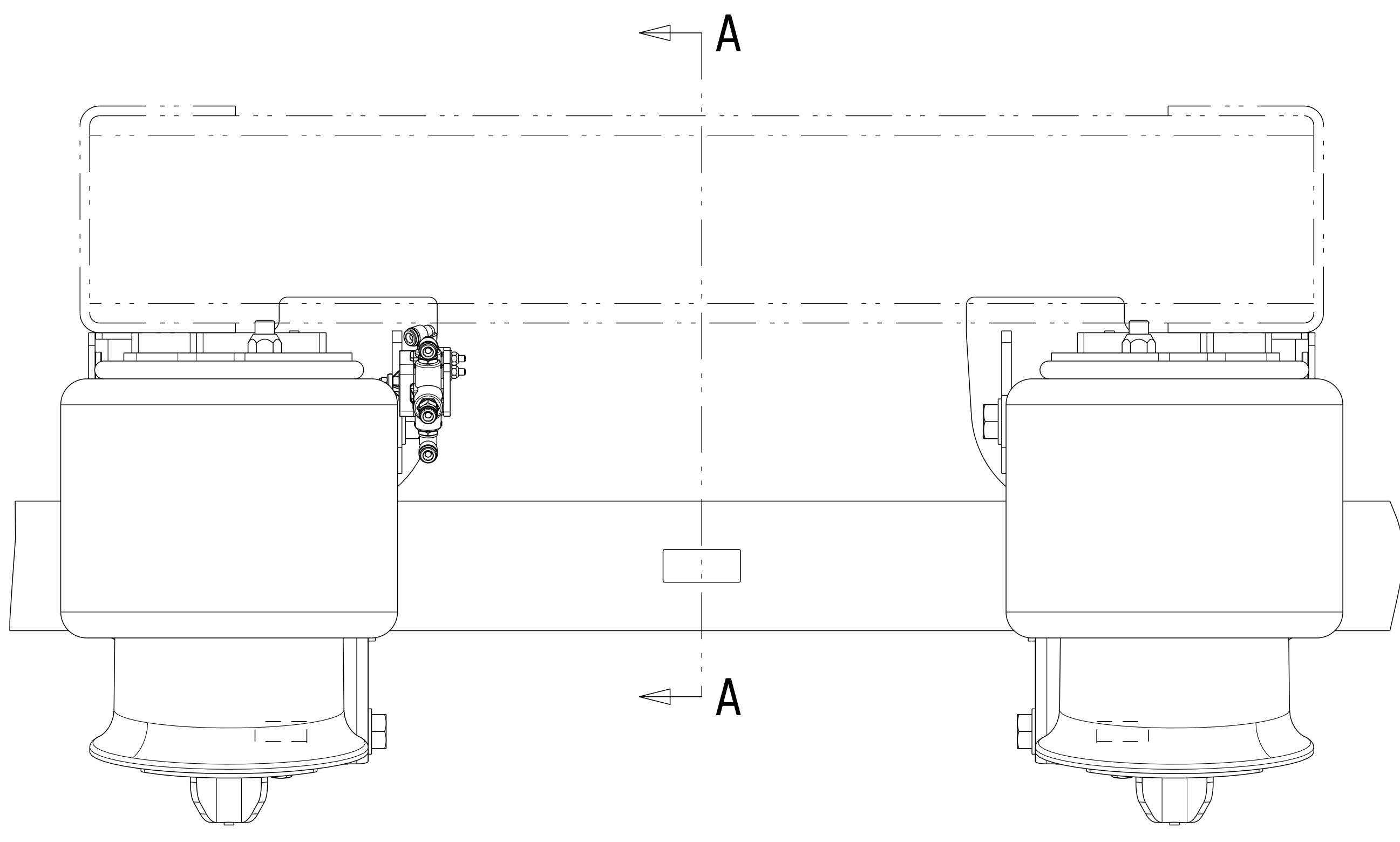
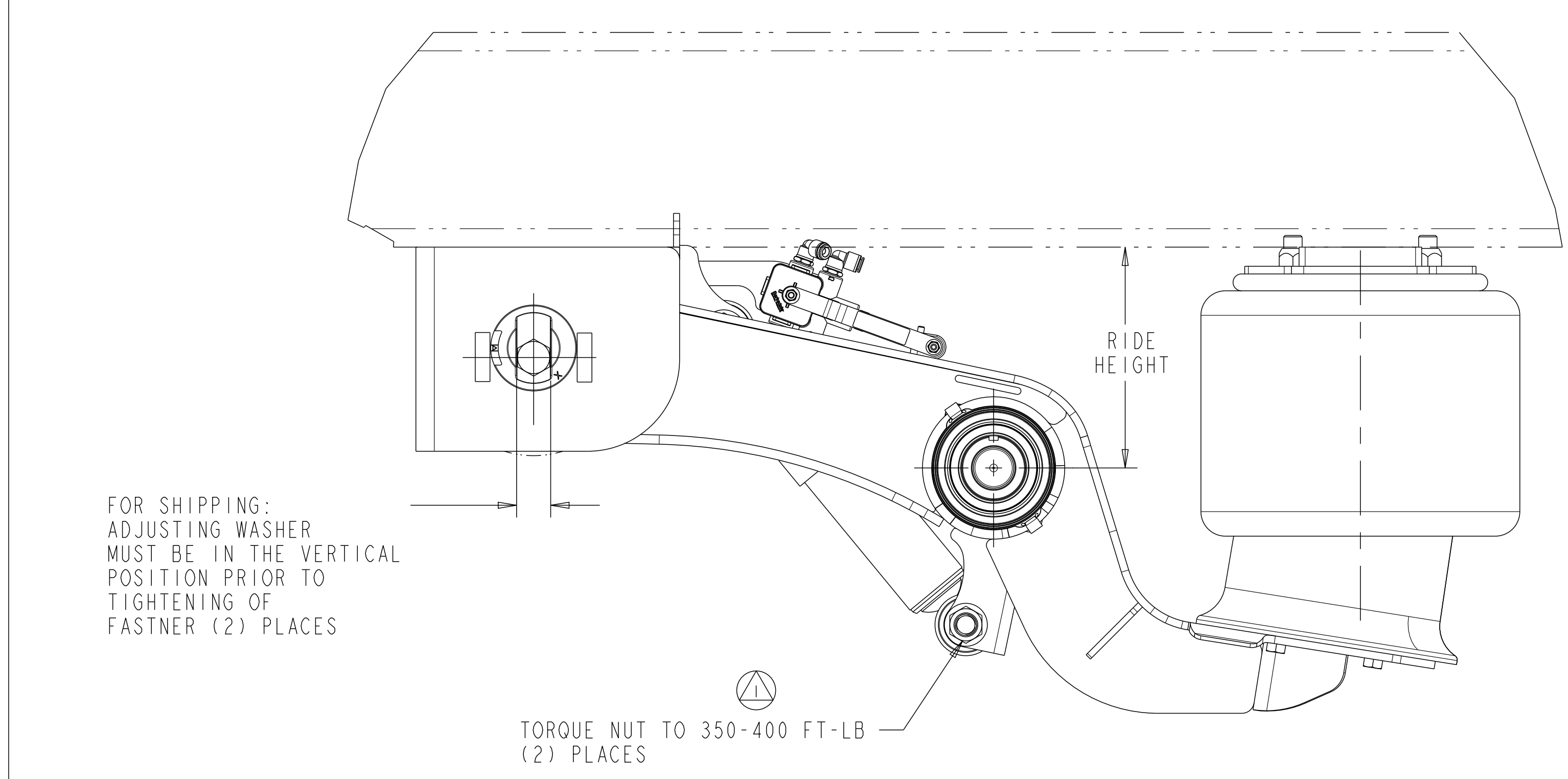

DO NOT CHANGE MANUALLY

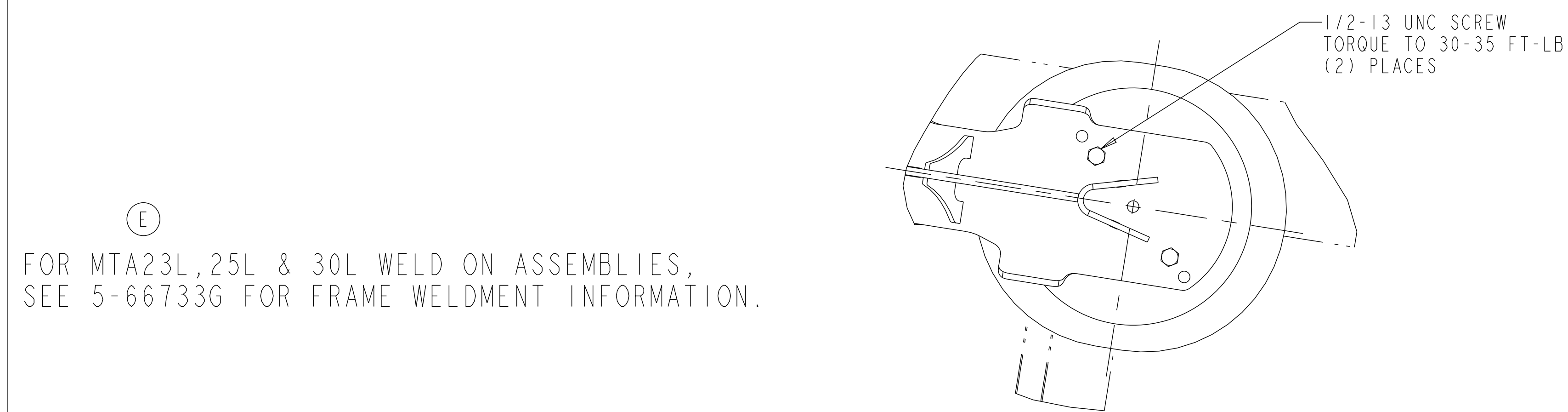

SUSPENSION SERIES: MTA LOW MOUNT

NOTE:  
TORQUE ALL FASTENERS WITH SUSPENSION AT RIDE HEIGHT

APPLY SPECIFIED MERITOR MARKINGS PER DRAFTING ENGINEERING STANDARDS D-004	THIS PRINT IS LOANED ON A CONFIDENTIAL BASIS SUBJECT TO RETURN UPON DEMAND BY MERITOR AND NOTHING HEREON MAY BE REPRODUCED, USED OR DISCLOSED IN WHOLE OR IN PART WITHOUT THE PRIOR WRITTEN PERMISSION OF MERITOR.	MATERIAL	SEE BILL OF MATERIAL FOR SPECIFIC INDIVIDUAL MODEL INFORMATION				RELEASE	PART/DWG NO. 4-60559-38	EDC 00909
			PROCESS	APPROVED	DRAWN BY	CHECKED BY			
INQUIRY NO. -		C.R./T.E. NO. PCCR 119179 / 119183	APP. NO.	ORIGINAL FOR MTA 23L / 25L / 30L	SCALE 1:4	DESIGN CONTROL GROUP W.W. TRAILER PRODUCTS	PART NO.	PAGE 1 OF 1	