

# INSTRUCTION MANUAL

FOR

## JACOBS ENGINE BRAKE

### MODEL #20

The Model 20 Jacobs Engine Brake is designed for use on the following Cummins Engine Models:

NHC-4	NH-220	NTE-235
NH-180	NHS-6	NT0-6
NHE-180	NHRS-6	NRT-6
NH-195	NT-4	NRTO-6
NHE-195	NT-6	NFT-6

The Jacobs Engine Brake will also fit all other NH Series 5-1/8" Bore Cummins Engines.



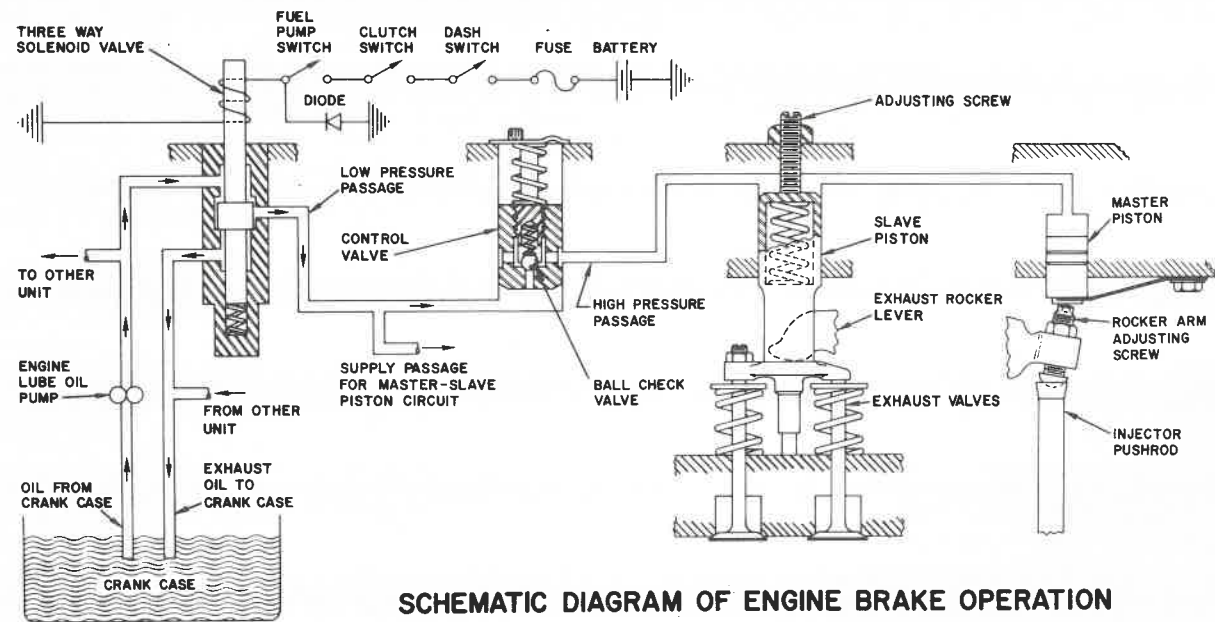

**SCHEMATIC DIAGRAM OF ENGINE BRAKE OPERATION**

**THEORY OF OPERATION** - Simply stated, energizing the Engine Brake effectively converts a power producing diesel engine into a power absorbing air compressor. This is accomplished when desired by motion transfer through a master-slave piston arrangement which opens cylinder exhaust valves near the top of the normal compression stroke releasing the compressed cylinder charge to exhaust.

The blowdown of compressed air to atmospheric pressure prevents the return of energy to the engine piston on the expansion stroke, the effect being a net energy loss since the work done in compressing the cylinder charge is not returned during the expansion process.

**EXHAUST BLOWDOWN** - Referring to the schematic drawing, exhaust blowdown occurs as follows:

1. Energizing the solenoid valve permits engine lube oil to flow under pressure through the slave piston control valve to both the master piston and the slave piston.
2. Oil pressure causes the master piston to move down, coming to rest on the injector rocker arm adjusting screw.
3. The injector rocker arm adjusting screw begins upward travel (as in normal injection cycle) forcing the master piston upward and creating a high pressure oil flow to the slave piston. The ball check valve in the control valve imprisons high pressure oil in the master-slave piston system.
4. The slave piston under the influence of the high pressure oil flow moves down, momentarily opening the exhaust valve, while the engine piston is near its top dead center position, releasing compressed cylinder air to the exhaust manifold.
5. Compressed air escapes to atmosphere completing a compression braking cycle.

**METHOD OF DRIVING A VEHICLE EQUIPPED WITH A JACOBS ENGINE BRAKE**

The proper method of driving a vehicle equipped with a Jacobs Engine Brake will be simple for an operator to learn. Since the Engine Brake is most effective at rated engine speeds, gear selection is very important. Gearing down the vehicle, within the limits of rated engine speed, makes the Engine Brake a more effective retarder. Obviously, maximum retarding occurs with the selection of the lowest gear that prevents exceeding rated engine speed.

The Model #20 Engine Brake kit contains a progressive switch that provides two, four or six-cylinder operation of the Engine Brake. This switch provides the operator with greater flexibility of engine retarding.

After short practice, drivers will learn the combination of gears that will give the best results over a particular route.

**ENGINE PREPARATION**

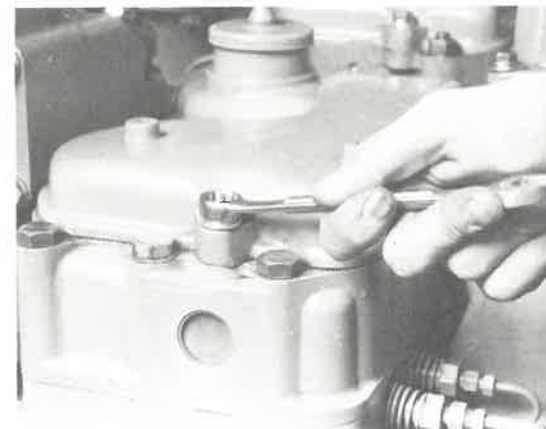

Clean engine thoroughly and remove rocker housing covers.

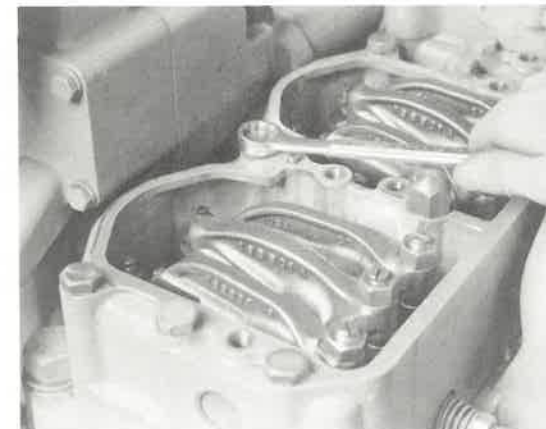

Remove rocker housing assemblies.



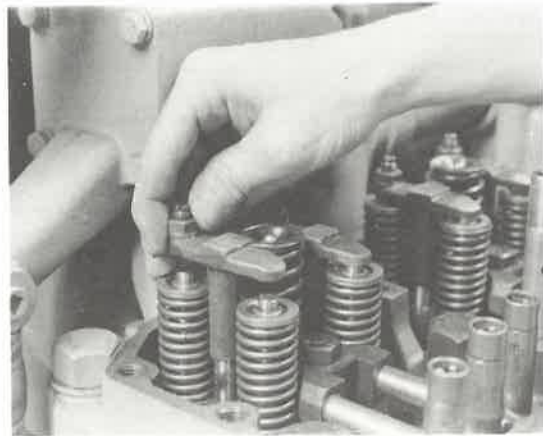

Remove exhaust valve crossheads.



Install Jacobs crossheads from kit on exhaust sides of heads. Remove crosshead adjusting screws from old crossheads and install in new crossheads.

NOTE: Beginning with engine serial No. 227236, use sleeve type crosshead, Jacobs No. 1239. On engine built previous to No. 227236, solid type crosshead, Jacobs No. 1003 should be used.

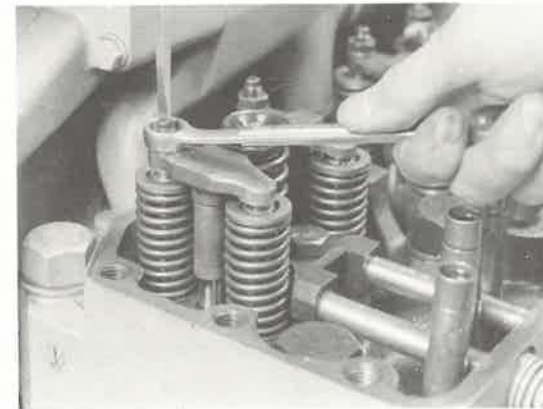

Adjust crosshead leveling screws as instructed in the Cummins Engine Company Shop Manual.

Torque locknuts to 25-30 ft. lbs. (34-41 N·m)

Current production rocker housings have an Allen head set screw to lock the rocker shaft. The set screw does not have to be removed.

However, earlier engine configurations utilize a cap screw and a locking plate to locate and lock the rocker shaft. For installations on engines of this design it is necessary to remove the rocker shaft lock plate. Remove as shown and reinstall lock screw only. Brake housing prevents lock screw from backing out.

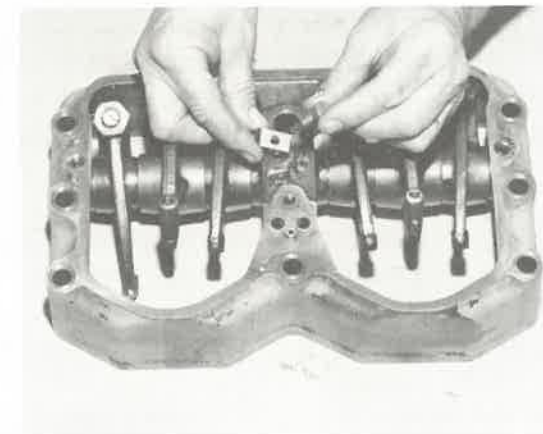

NOTE: If rocker housing P/N BM92687 is used for installation, delete the following rocker grinding information.

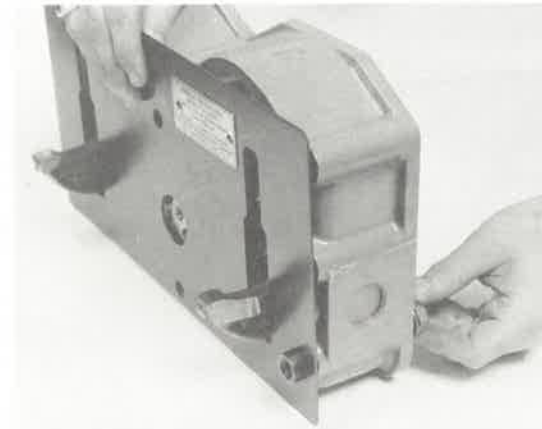

Remove adjusting screws from exhaust rocker levers. Orient rocker housing as shown with flat side on work bench. Orient rocker lever gauge, Part No. 1153 with Name Plate side out, gauging slots upward and insert rocker lever feet through wide slot. Secure gauge by installing two 1/2 x 13 cap screws through rocker housing into captive nuts on gauge. Tighten securely but not heavily with wrench.

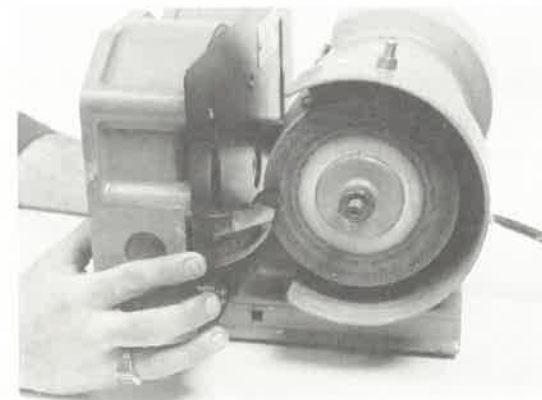

Elevate rocker box as required in front of grinder as shown. Hold exhaust rocker in position with thumb and grind both sides lightly. (Do not draw temper of rocker lever foot.)

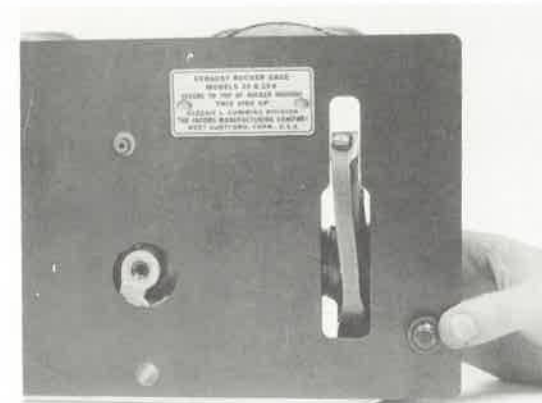

Check progress by pushing rear of rocker lever down with thumb and examine for interference with slot. Continue grinding until the rocker lever foot passes through the gauge slot. Remove gauge. Remove burrs from rocker lever foot and clean rocker assembly thoroughly. Reinstall exhaust rocker lever adjusting screws.

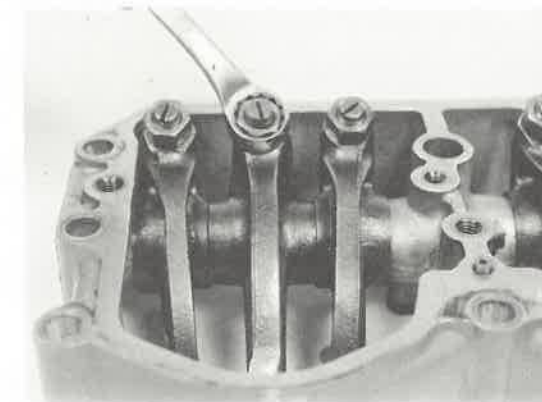

Remove injector rocker lever adjusting screws.

## ENGINE PREPARATION

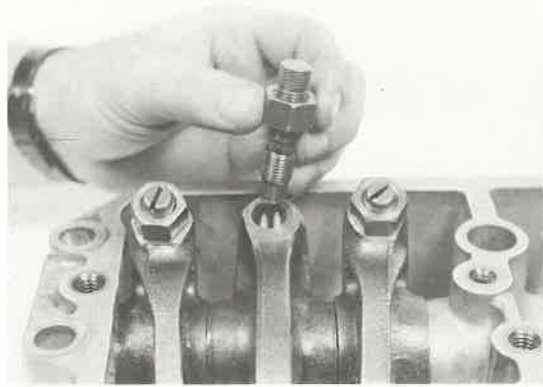

Replace injector rocker lever adjusting screws with new adjusting screws from kit. (These screws have a hex head instead of a screw driver slot.)

Note: Either 1/2" (12.7mm) or 5/8" (15.9mm) diameter thread depending on size of screws removed from engine.

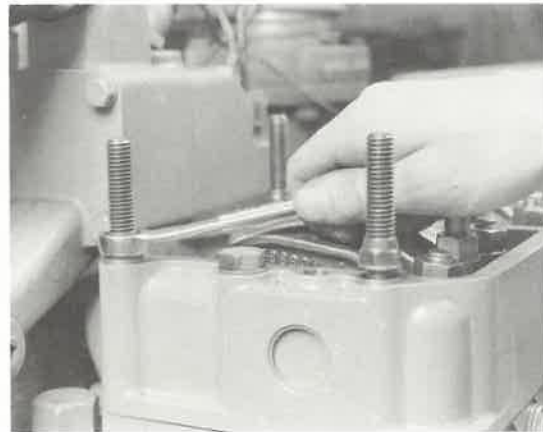

Place rocker housing assemblies back on heads. Install extension studs from kit in place of original cap screws (5 places only). Reinstall original cap screws in center of each end of rocker housing. (Note cap screw in picture.)

In the event that engine is equipped with compression release, with or without fan support bracket, refer to instructions on Pages 10 and 11.



If engine is equipped with aluminum rocker housings, install special steel washers, which are supplied in kit, under stud nuts. The washers are installed to prevent housing distortion and must be positioned pilot side down as shown.

**CAUTION:** DO NOT USE STEEL WASHERS WITH CAST IRON ROCKER HOUSINGS.

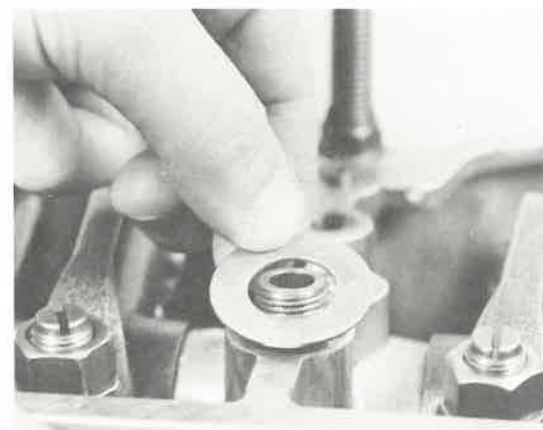

Install oil tube extension washer over oil tube on top of rocker housing.

## ENGINE PREPARATION

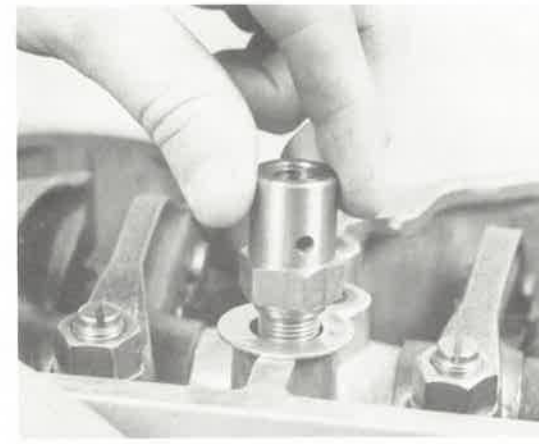

Install oil tube extension.

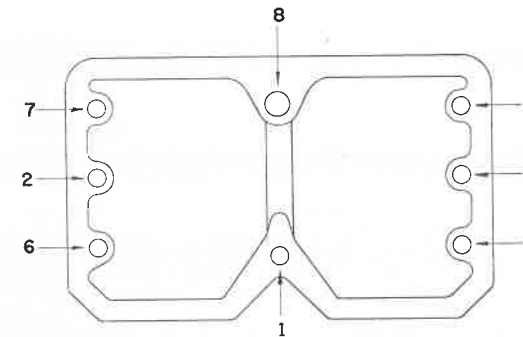

Torque holddown studs, cap screws, and oil tube extension to 65-75 ft. lbs. (80-102 N•m) following the sequence as shown.

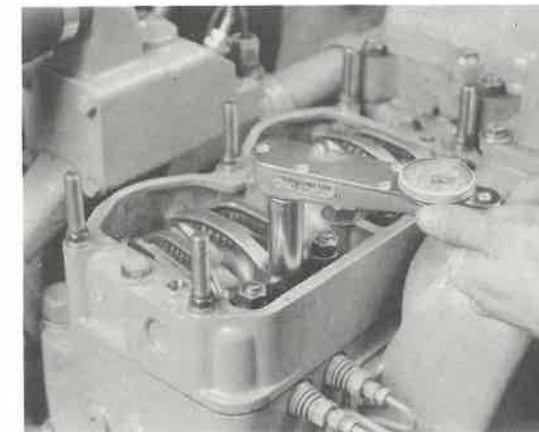

Adjust valves and injectors as shown in the Cummins Engine Company Shop Manual.

## INSTALLATION OF BRAKE UNITS ON ENGINE

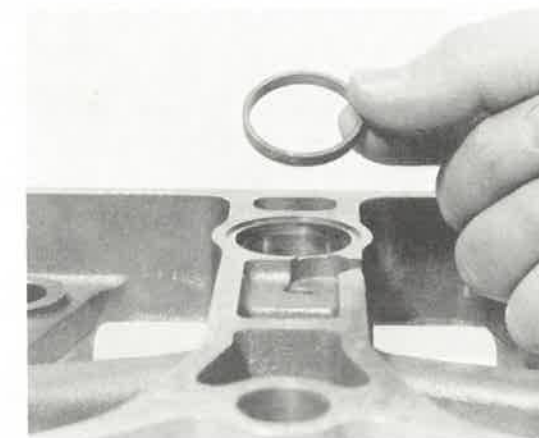

Install oil seal ring from kit in oil tube nut counterbore in bottom of Engine Brake housing. Use grease if needed to hold seal in place.



INSTALLATION OF BRAKE UNITS ON ENGINE

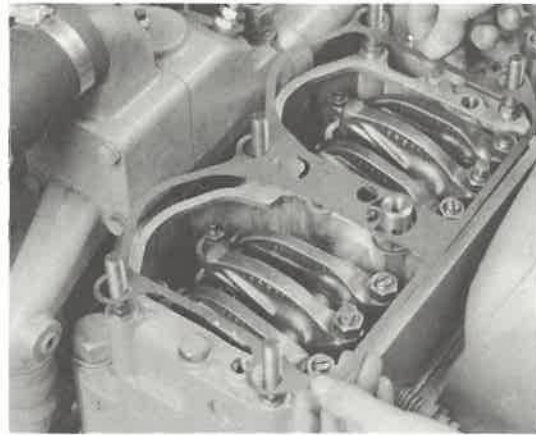

Install Jacobs gasket on rocker housing.

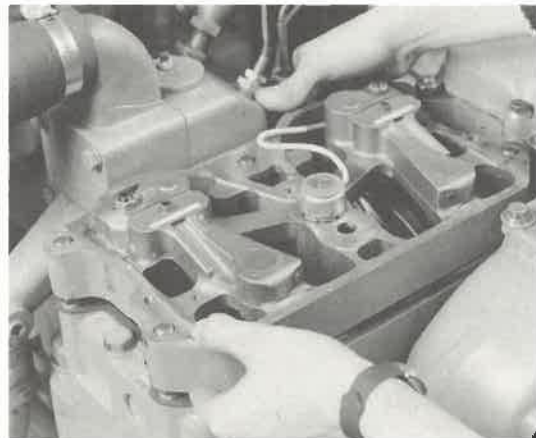

Install Engine Brake units. These must drop in place with no binding on rocker levers.

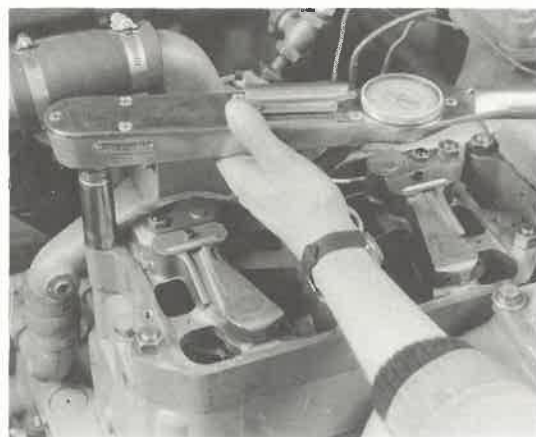

Install five brake housing hold-down nuts on each unit.



Install Allen head screw with washer in oil tube extension nut.

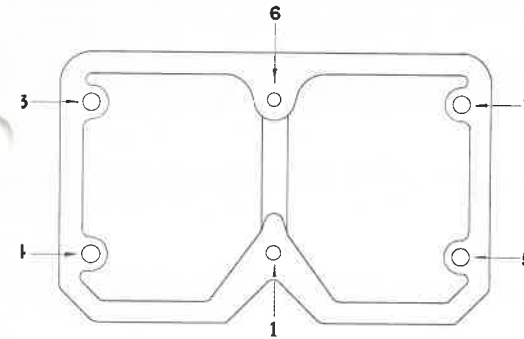

Torque brake housing holddown nuts and Allen head screw to 55 ft. lbs. (75 N·m) following sequence shown. Torque procedure should be taken in steps to ensure even Engine Brake seating.

SLAVE PISTON  
ADJUSTMENT PROCEDURE

Loosen and back off locknut. Insert Allen Wrench and back slave piston adjusting screw out of housing until slave piston seats in its bore.

Slave piston adjustment must be made with the engine STOPPED COLD and the exhaust valves closed.

Bar the engine in the direction of rotation until "A" or "1-6 VS" mark on accessory drive pulley lines up the timing mark on the gear case cover. With the engine in this position, the exhaust valves of cylinders 1 or 6 are closed. Loosen and back off lock nut. Insert socket head wrench and back slave piston adjusting screw out of housing until slave piston seats in its bore. Insert a 0.018" (0.46mm) Jacobs PN 3087 feeler gauge between the slave piston and the cross head, turn the adjusting screw in until a slight drag is felt on the feeler gauge. Tighten lock nut. Continue turning the engine in direction of rotation and set slave piston clearance on remaining cylinders in firing order.

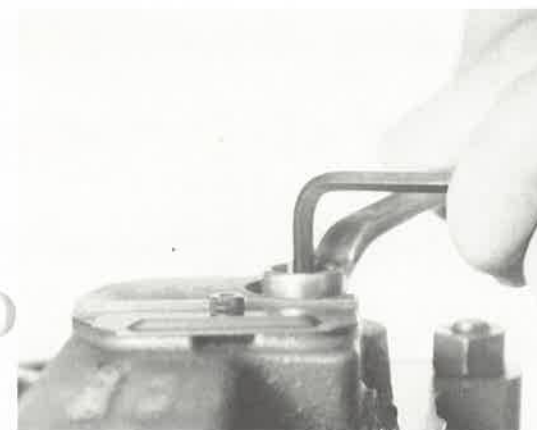

Hold the adjusting screw in position with the Hex head wrench and tighten the locknut securely. Torque adjusting screw locknut to 15-18 ft. lbs. (20-24 N m).

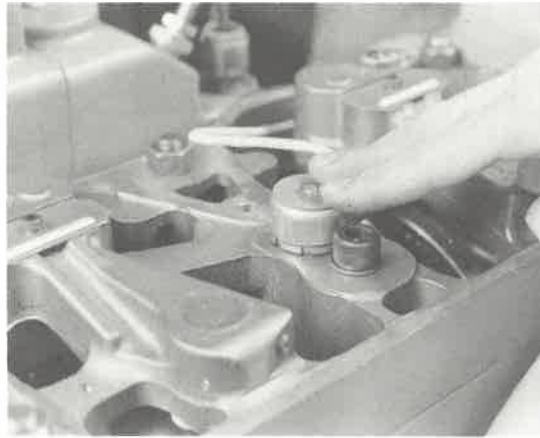

To bleed brake units for immediate operation, manually depress solenoid armature five or six times in succession with engine running to permit oil to fill passages in housing.

Install valve cover and gasket.

If any interference between cover and brake unit is noted, remove cover and relieve where needed. If interference with oil filler cap occurs, reposition filler cap to seal at a higher point in the filler neck.

For Engine Brake installations on Supercharged or Turbocharged Engines spacers are furnished, in accessory kits, to provide necessary clearance needed for additional height of Engine Brake.

REBUILDING OF COMPRESSION RELEASE ASSEMBLY

If engine is equipped with compression release, with or without fan support brackets, it will be necessary to substitute special extension studs in the front three locations of the rocker housing over cylinders 1 and 2 and to modify the compression release assembly as shown in this section. All additional parts required are supplied in the compression release modification kit.

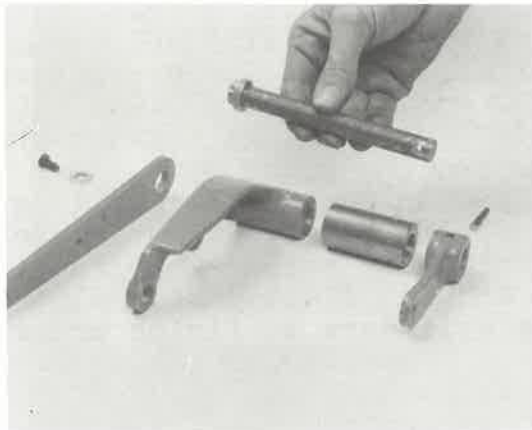

Remove cross pin in lower lever and disassemble. Replace center shaft with longer shaft furnished in kit and install spacer.



The spacer is required to provide additional height of Engine Brake. Reassemble and install new cross pin from kit.

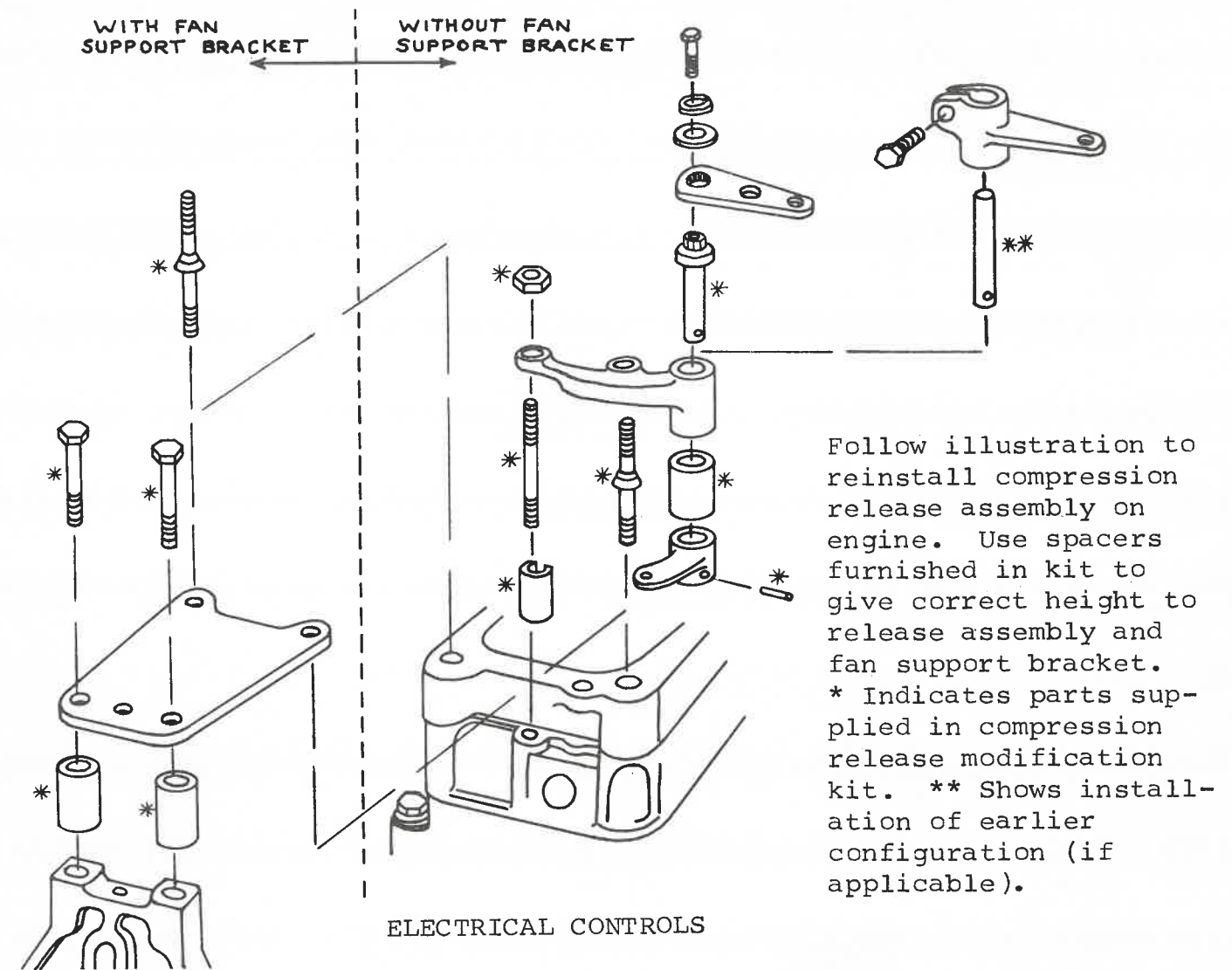

Follow illustration to reinstall compression release assembly on engine. Use spacers furnished in kit to give correct height to release assembly and fan support bracket. \* Indicates parts supplied in compression release modification kit. \*\* Shows installation of earlier configuration (if applicable).

The Engine Brake controls consist of a dash switch, a clutch switch and a throttle switch.

The two position dash switch ("Automatic" and "Off"), placed on the dash board is used to activate the Engine Brake. This switch must be in the "Off" position when the engine is not running and should be left in the "Automatic" position while the truck is being driven. In the "Automatic" position the Engine Brake is controlled automatically through the throttle and clutch switches.

The throttle switch allows the operator to decrease speed by simply lifting his foot off the throttle. Fuel flow to the cylinders will stop and the Engine Brake will operate.

The clutch switch de-energizes the Engine Brake during periods of clutch depression to facilitate lower gear selection and to establish normal engine operation while the truck is at a complete stop.

These effortless means of switch actuation provide flexible Engine Brake control and automatically insure that no fuel will be supplied to the cylinders during Engine Brake operation.



CONTROL MOUNTING INSTRUCTIONS

It should be noted that the following instructions depict recommended installations and are designed to be used as a guide. In some extreme applications, it may not be feasible to mount switches exactly as shown, and a more advantageous location may be used, providing intended operation is not affected.

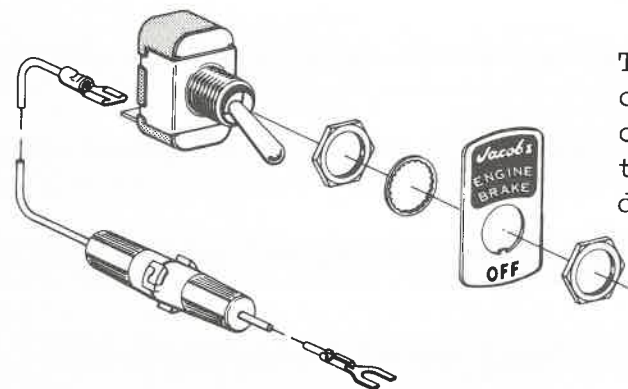

DASH SWITCH MOUNTING:

The dash switch should be located conveniently for the driver, and close to the key switch. Connect to fuse harness as shown in wiring diagram on Page 13.

THROTTLE SWITCH (FUEL PUMP) MOUNTING:

Mount fuel pump switch and actuating arm as shown, using cap screws on fuel pump to secure switch. Actuating arm may be bent or relocated to contact switch when throttle lever is in idle position.

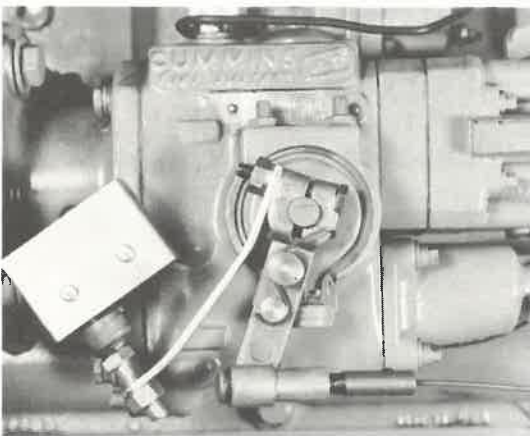

ADJUSTMENT: Adjust screw in actuating arm so that an audible "click" is heard when throttle arm moves to an idle fuel position.

CAUTION: Check PT Fuel Pump Throttle Shaft to insure that throttle pedal will move the throttle shaft to the full fuel position after installation of the actuating arm.

CLUTCH SWITCH MOUNTING:

Mount enclosed switch so that adjustable rod on switch actuator is in contact with clutch pedal arm.

ADJUSTMENT: With clutch pedal in relaxed position, loosen actuator rod clamp so that switch "clicks" with rod in contact with clutch arm. Tighten clamp in this position. This adjustment should allow switch to work during the clutch pedal play before actual clutch disengaging takes place.

CONTROL MOUNTING INSTRUCTIONS

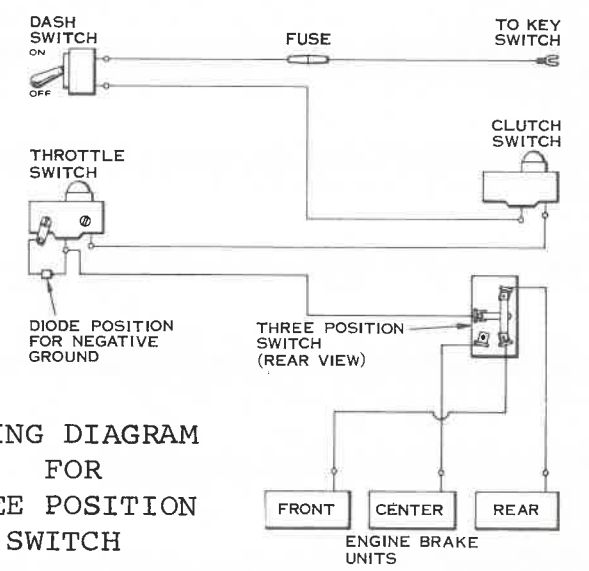
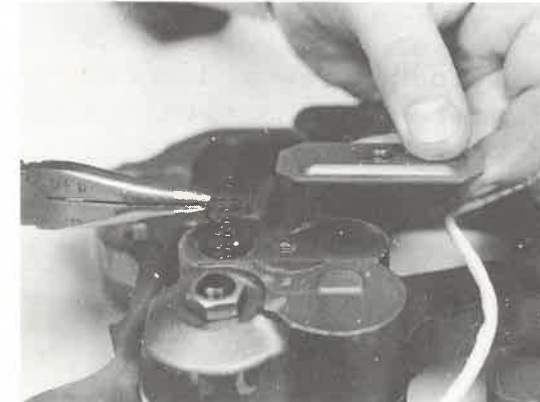
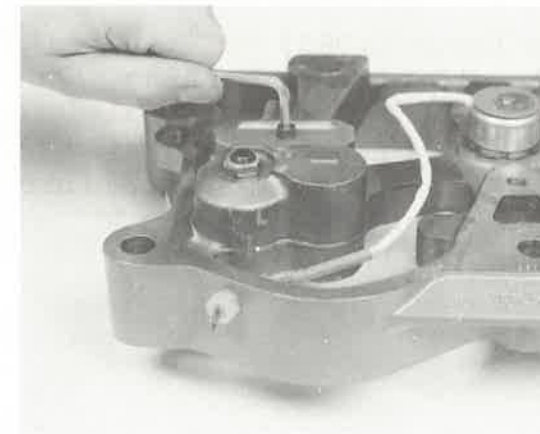
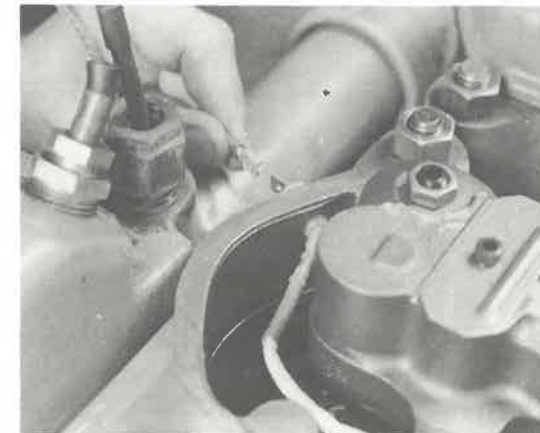
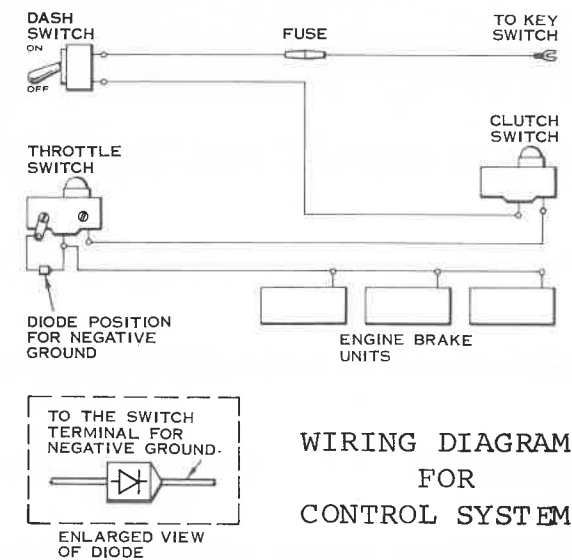

Connect wiring harness from controls. See wiring diagram.

REMOVAL AND INSTALLATION OF CONTROL VALVE ASSEMBLY

Remove control valve cover plate.

Remove control valve spring.

## REMOVAL AND INSTALLATION OF CONTROL VALVE ASSEMBLY

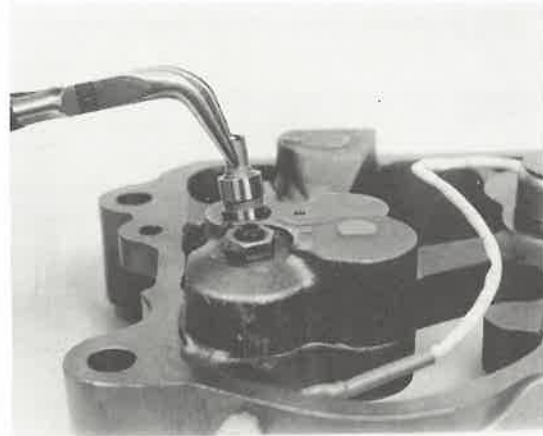

Remove control valve assembly. To reinstall, reverse above procedure.

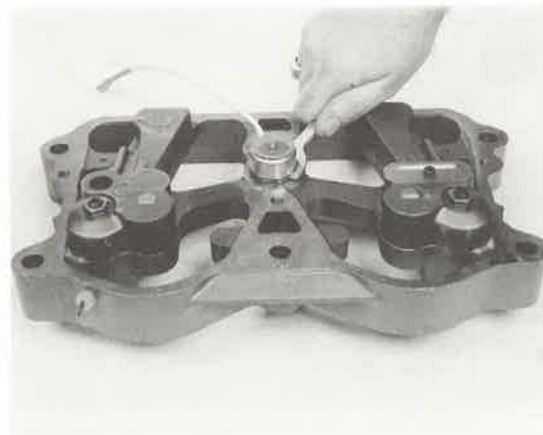

### REMOVAL AND INSTALLATION OF SOLENOID UNIT

Disconnect wiring. Remove solenoid valve with special spanner wrench as shown.



Insert lower (1083) "O" ring in bottom of solenoid bore in housing. Install upper (1081) "O" ring on solenoid valve. Install center (1082) "O" ring on solenoid valve. Insert solenoid into housing gently without disturbing "O" ring positions.

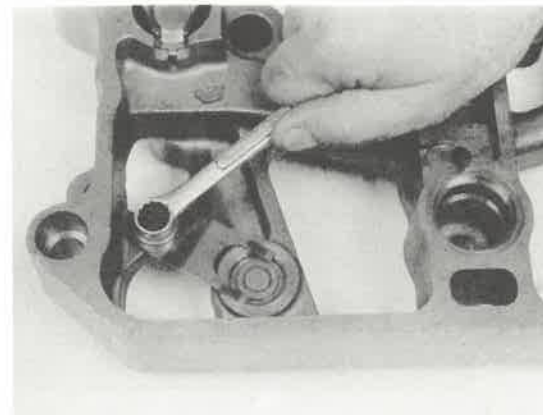

### REMOVAL AND INSTALLATION OF MASTER PISTON

Remove Nylock screw and spring holding master piston in position. Slide out master piston.

## REMOVAL AND INSTALLATION OF MASTER PISTON



Reassemble and install in the same order as removed with CONCAVE part of spring toward piston as shown. This spring must be assembled as shown and centered on turned boss on top of piston.

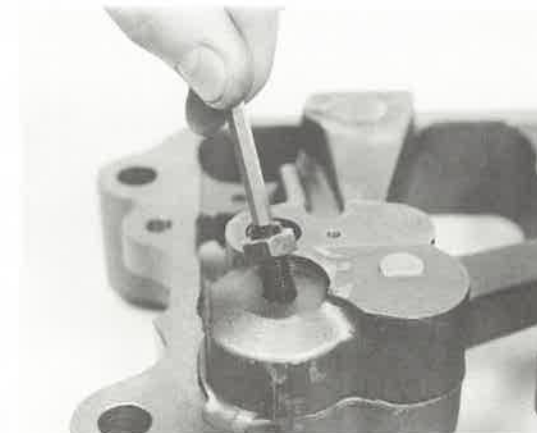

### REMOVAL AND INSTALLATION OF SLAVE PISTON

Remove slave piston adjusting screw with 3/16th Allen wrench.

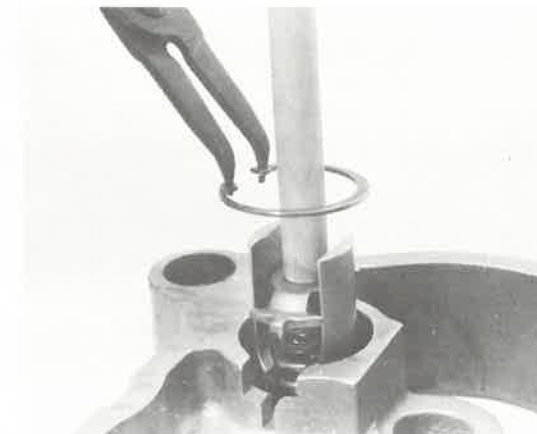

To relieve tension on snap ring, compress slave piston spring slightly by pushing down on spring retainer.

This spring is under heavy compression and care should be used in its removal.

Remove snap ring using special pliers furnished in tool kit.



Remove spring retainer, spring and slave piston.

Reassemble components, using same procedure as when removed. Be sure retainer is in same position as shown in picture.



# INSTRUCTION MANUAL SUPPLEMENT

FOR

## MODEL 20 JACOBS ENGINE BRAKE WITH HOLD-DOWN PISTONS

FOR USE ON ENGINES WITH S.D. (SINGLE DISC) OR D.D. (DOUBLE DISC)  
FUEL SYSTEMS

THIS SUPPLEMENT TO BE USED IN CONJUNCTION WITH  
THE PREVIOUS INSTRUCTIONS IN THIS MANUAL.

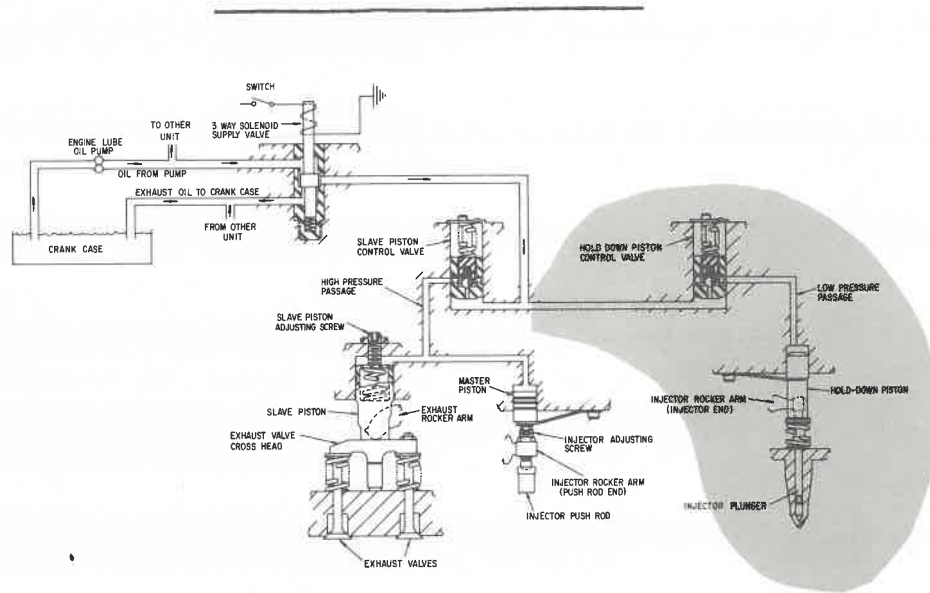

Schematic of Model 20 Brake with hold-down piston.  
Shaded portion denotes hold-down circuit.

The hold-down piston locks the injector plunger in the shut-off position preventing fuel delivery to the cylinders during Engine Brake operation.

### DASH SWITCH

NOTE: Substitute the following for dash switch mounting information contained on Page 12 of this Manual.

Model 20 Engine Brakes for engines with S.D. or D.D. Fuel Pumps utilize a hold-down circuit to shut-off fuel flow to the cylinders during engine braking. This positive mechanical means of injector closing allows the installation of a three position dash switch with a manual override (See Photo). The three position switch affords the driver an alternative of bypassing the clutch and throttle controls, thereby gaining independent brake operation through the dash switch only.

The three position dash switch should be mounted conveniently for the driver and located close to the key switch. Connect to fuse harness as shown in wiring diagram on Page 17.

# INSTRUCTION MANUAL SUPPLEMENT

## THROTTLE SWITCH (THROTTLE SHAFT) MOUNTING:

NOTE: Substitute the following for throttle switch (fuel pump) mounting information contained on Page 12 of this manual.

The S.D. or D.D. Fuel Pump does not accept the fuel pump mounted throttle switch. It is therefore necessary to install the throttle shaft type switch.

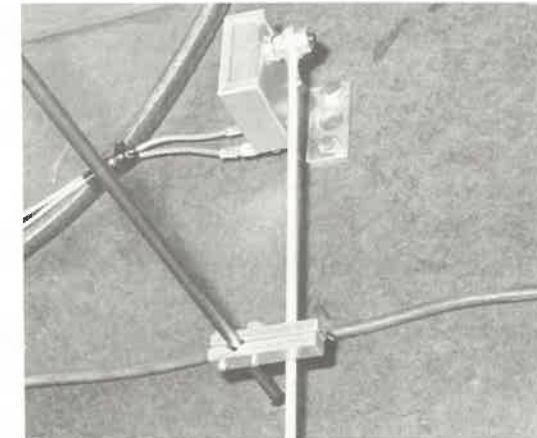

Mount the throttle rod clamp on throttle control rod as shown in picture. Mount the switch on the fire wall (engine side) on a suitable bracket. The switch should be mounted so that control rod contacts clamp as shown in picture.

ADJUSTMENT: The throttle must be in the closed position and the engine stopped. With clamp loose enough to slide on the throttle rod, move clamp until it contacts control rod. Continue to move clamp until switch is activated as indicated by an audible "click." Tighten clamp in this position.

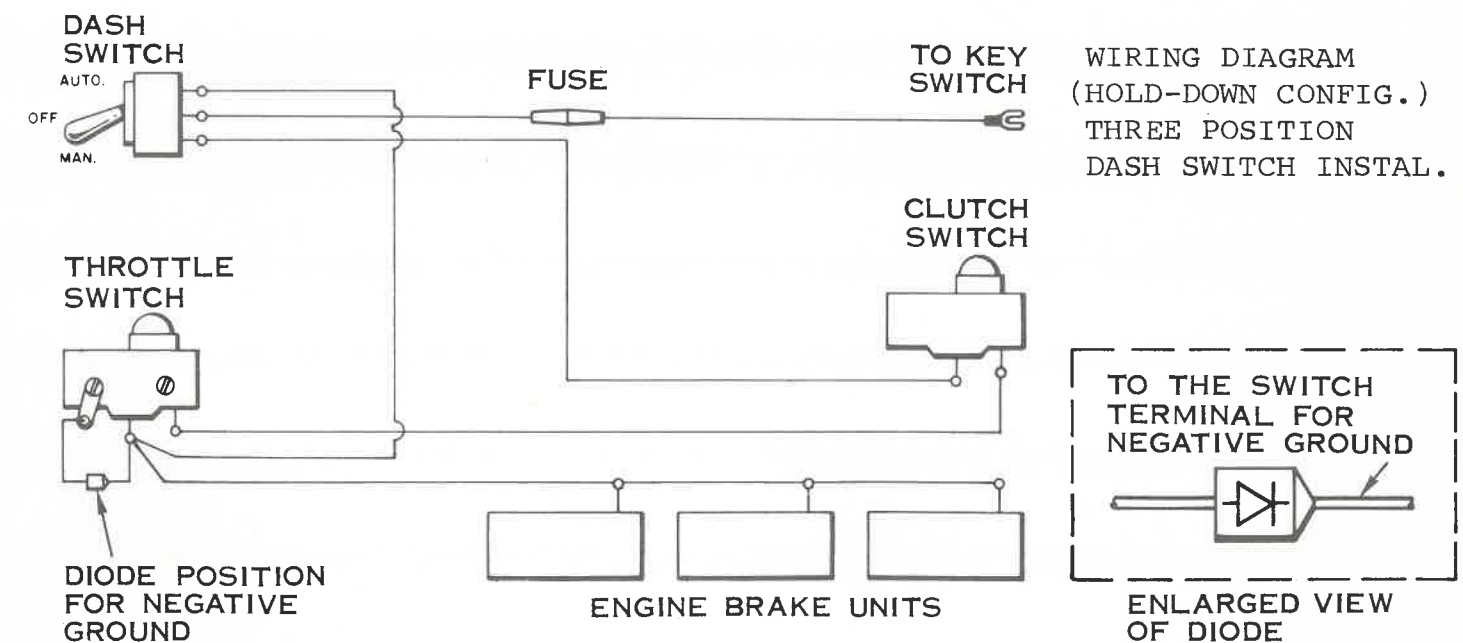

NOTE: Substitute for wiring diagram contained on Page 13 of this manual.

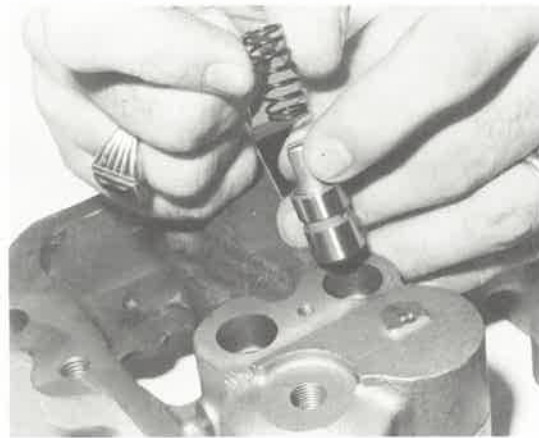

REMOVAL AND INSTALLATION OF  
HOLD-DOWN PISTON CONTROL VALVE

The hold-down piston control valves are located just inboard of the slave piston control valves. (Bores closest to solenoid, one per cylinder). Remove cover plate and valve spring. Lift out control valve.

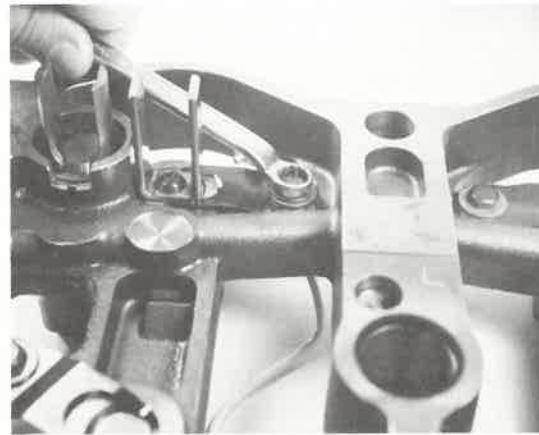

REMOVAL AND INSTALLATION OF  
INJECTOR HOLD-DOWN PISTON

Remove Nylock screw holding injector plunger hold-down spring, and remove piston from housing.



Note that feet on spring as shown are designed to push piston as far as possible into brake housing. To install, reverse removal procedure.

REMOVAL OF INJECTOR PLUNGER BAIL

If brakes are to be installed on engines with S.D. or D.D. Fuel Systems it is imperative that the injector bail (CECO #66865) be removed from the injector. Failure to remove the bail will render the Engine Brake hold-down piston inoperative.

Removal of the bail must be done after setting the valves and injectors by prying the bail from its seat in the injector body.

**JACOBS ENGINE BRAKE LIMITED WARRANTY**

The Jacobs Engine Brake, a product of The Jacobs Manufacturing Company Vehicle Equipment Division, is sold with the following warranty:

The Jacobs Engine Brake is warranted to be free of defects in construction and operation under normal use and service for the Warranty Coverage periods set forth below.

**THERE ARE NO REPRESENTATIONS OR WARRANTIES WHICH EXTEND BEYOND THE TERMS HEREOF OR THE DESCRIPTION OF THE PRODUCT CONTAINED IN THE CONTRACT FOR SALE.**

Warranty Coverage:

Engine Brake housing assembly and related attaching parts except seals, O-rings and gaskets—one year or 100,000 miles (161,000 kilometers), whichever shall first occur.

Replacement Parts installed during the original Warranty Coverage period are warranted for the remainder of that period, but not less than 3 months or 24,000 miles (38,600 kilometers), whichever shall first occur. Replacement Parts installed after the expiration of the original Warranty Coverage period on new equipment are warranted for 3 months or 24,000 miles (38,600 kilometers), whichever shall first occur.

Under this warranty our factory is obligated to replace, without charge, any part returned to us which our examination discloses to our satisfaction to have been defective within the Warranty Coverage period measured from the date of delivery of the product in question to the original user.

Jacobs will also pay for all repairs to damaged engine components in which a Jacobs Engine Brake or Jacobs Replacement Parts have been properly installed, provided the damage is shown to be a direct result of a defect of the Jacobs Engine Brake or Jacobs Replacement Parts occurring under normal operation during the Warranty Coverage periods specified above.

This warranty will not apply to any part or parts which have been altered or repaired outside of our factory or authorized Jacobs distributor service centers, nor to parts which have been subjected to misuse, abuse, neglect, or accident, nor to parts which have been improperly applied or installed. Improper installation or application, or substitution of parts not manufactured or approved by us, shall void this warranty.

If the product should become defective within the Warranty Coverage period, an authorized Jacobs Engine Brake Distributor should be notified. There is a world wide network of authorized distributors whose names and addresses can be found in the Sales and Service Directory located in the back of your Jacobs Engine Brake Driver's Manual. If any of the listed distributors are unable to correct your problem or if you have any questions regarding this warranty, write to the following address giving full details of your problem including the Model and Serial Numbers of the product involved.

**WARRANTY ADMINISTRATOR  
THE JACOBS MANUFACTURING COMPANY  
VEHICLE EQUIPMENT DIVISION  
EAST DUDLEY TOWN ROAD  
BLOOMFIELD, CONNECTICUT 06002**

**JACOBS SOLE LIABILITY AND YOUR EXCLUSIVE REMEDY IS LIMITED TO THE OBLIGATIONS SET FORTH HEREIN, AND JACOBS SHALL NOT BE LIABLE FOR ANY SPECIAL, INDIRECT OR CONSEQUENTIAL DAMAGES.**



# INSTRUCTION MANUAL

FOR

## JACOBS ENGINE BRAKE

### MODEL #20

The Model 20 Jacobs Engine Brake is designed for use on the following Cummins Engine Models:

NHC-4	NH-220	NTE-235
NH-180	NHS-6	NT0-6
NHE-180	NHRS-6	NRT-6
NH-195	NT-4	NRTO-6
NHE-195	NT-6	NFT-6

The Jacobs Engine Brake will also fit all other NH Series 5-1/8" Bore Cummins Engines.

