

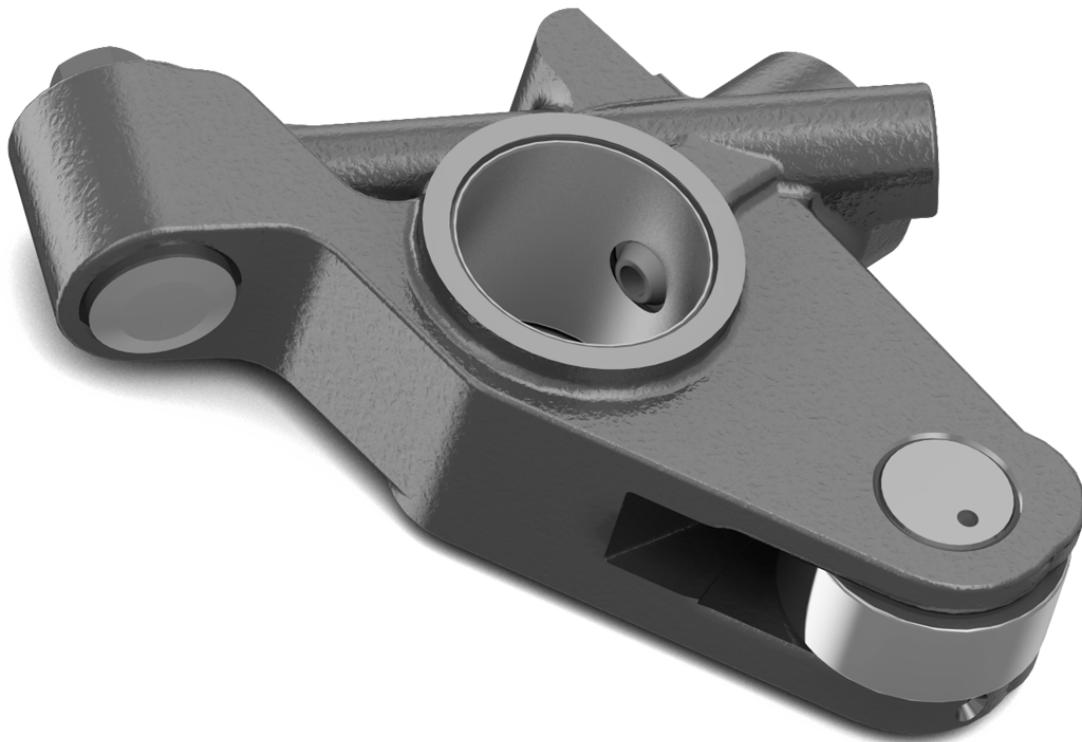

**Jacobs Vehicle Systems®**

# Intebrake™ Engine Brake Tune-Up Kit

Signature, ISX, QSX15 Engines P/N 2882081



## Tune-up Kit Contents

Illus No.	P/N	Part Name	Quantity per kit
1	3686406	Solenoid, 12VDC Thread Terminal (Type II)	-
1	4024759	Solenoid, 12VDC S/L (Type I)	-
2	3871638	Seal, Solenoid Upper	3
3	4026537	Seal, Solenoid Center	3
4	3871218	Seal, Solenoid Lower	3
5	3685827	Manifold Clamp - Type II	-
5	3104916	Manifold Clamp - Type I	-
<b>4298199</b>		<b>Lever Assy</b>	
6	3413127	Lever Sub Assy (NSS)	-
7	3413129	Control Valve Assembly	6
8	2892986	Control Valve Spring	6
9	3413131	Control Valve Cover	6
10	3413132	Retaining Clip	6
11	3679921	Hex Nut	-
12	2882738	Actuator Piston	-
13	4298248	O-Ring (.426ID)	3
14	4298247	O-Ring (.614ID)	3
15	3902093	Screw, Socket (6MM10LG)	-
NI		Instructions	1

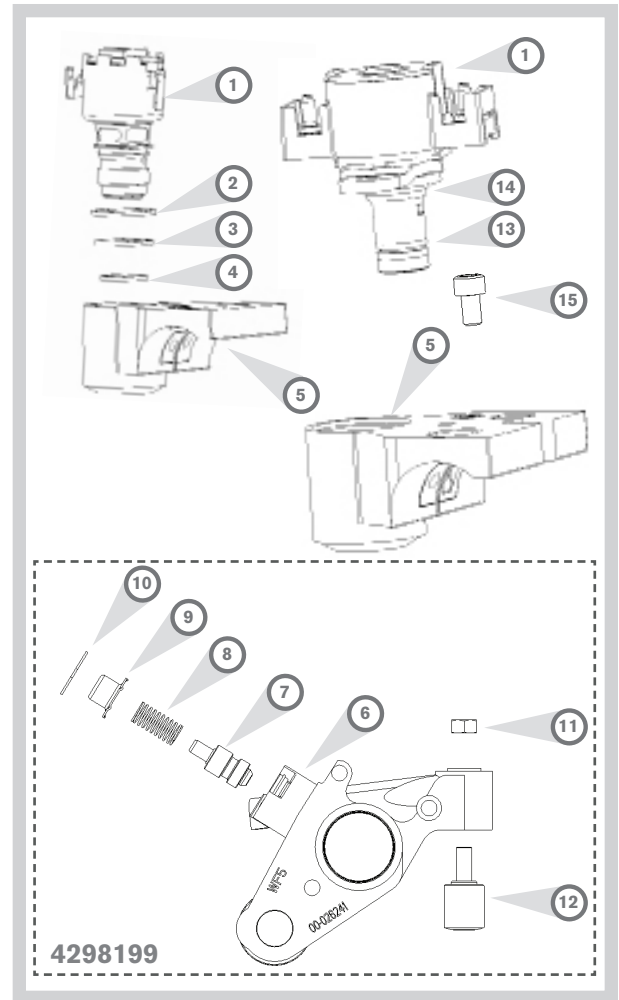

NSS – Not Sold Separately

## GENERAL INFORMATION

These instructions describe how to properly remove, clean and reinstall Jacobs Engine Brake® components. For additional information on the Cummins Signature, ISX, and QSX15 engines see the Troubleshooting and Repair Manual, Bulletin No. 3666239.

The actuator piston lash and clearance settings listed on page 4 of this manual are current as of this printing.

Use OSHA-approved cleaning solvent for cleaning parts. Original parts to be reused should be inspected for wear and replaced as required. Be sure to coat parts with clean engine oil when reinstalling them.

The standard Cummins Service Parts Warranty applies to the components of this Tune-up Kit.

## SAFETY PRECAUTIONS

The following symbols in this manual signal conditions potentially dangerous to the mechanic or the equipment. Read this manual carefully. Know when these conditions can exist. Then take necessary steps to protect personnel as well as equipment.



**WARNING**

THIS SYMBOL WARNS OF POSSIBLE PERSONAL INJURY.



**CAUTION**

THIS SYMBOL REFERS TO POSSIBLE EQUIPMENT DAMAGE.

**NOTE:**

INDICATES AN OPERATION, PROCEDURE OR INSTRUCTION THAT IS IMPORTANT FOR CORRECT SERVICE.

Fuels, electrical equipment, exhaust gases and moving engine parts present hazards that could result in personal injury. Take care when installing equipment or parts. Always wear safety glasses. Always use correct tools and follow proper procedures as outlined in this manual.

## Instructions

### WARNING

NEVER REMOVE OR ADJUST ANY ENGINE BRAKE OR COMPONENT WITH THE ENGINE RUNNING

## ACCESS ENGINE BRAKE

1. Thoroughly clean engine.
2. Remove the eight capscrews and isolators from the Rocker Cover. Remove the cover.
3. Disconnect terminals on wiring harness from terminals on the solenoids.

### CAUTION

USE CARE WHEN HANDLING SHAFTS. ROCKER LEVERS CAN FALL OFF THE SHAFT DURING REMOVAL AND DAMAGE THE LEVERS.

4. Remove the valve and brake rocker lever shaft capscrews, the solenoid manifold assembly, and the rocker lever shaft assemblies. Remove the valve crossheads and crosshead guide pins.

**NOTE:** TO PREVENT INCREASED WEAR, MARK EACH CROSSHEAD, GUIDE PIN, AND ROCKER LEVER SHAFT ASSEMBLY AS IT IS REMOVED SO IT CAN BE INSTALLED BACK IN ITS ORIGINAL POSITION.

5. Inspect the valve and brake rocker lever shaft for any excessive wear around the brake detent hole. No further disassembly is required to complete the removal and replacement of the brake parts. Coat all parts to be installed with clean lube oil.

## Control Valve Removal and Replacement

### WARNING

WEAR SAFETY GLASSES. REMOVE CONTROL VALVE COVERS (9) CAREFULLY TO AVOID PERSONAL INJURY. COVERS ARE UNDER LOAD FROM CONTROL VALVE SPRINGS (8).

1. Use snap ring pliers to remove the snap ring, control valve cover (9), spring (8), and control valve (7).
2. Insert new control valve (7) into the control valve bore. Move the control valve in the bore to insure free movement and lubricate the assembly.
3. Insert the control valve spring (8), control valve cover (9), and snap ring (10). With your thumb on the control valve cover, press down on the assembly and lock the assembly into position with the snap ring. Make sure the open end of the snap ring is 180° opposite of the housing openings as shown in figure 1.
4. Repeat this procedure with the remaining control valves.

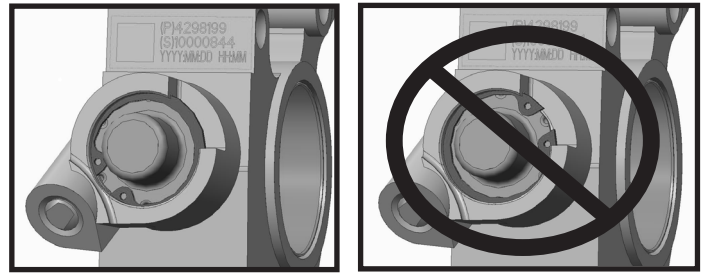

Correct Snap Ring

Incorrect Snap Ring

Fig. 1

## Install Rocker Lever and Brake Assembly

### CAUTION

CLEAR THE ROCKER LEVEL ASSEMBLY MOUNTING CAPSCREW HOLES OF OIL AND DEBRIS. EXTENSIVE DAMAGE CAN RESULT IF THIS WARNING INSTRUCTION IS NOT FOLLOWED.

1. Install the intake crossheads and exhaust crossheads with guide pins.
2. Install the valve/brake rocker level assemblies onto the cylinder head. Prior to bolting down a shaft assembly, bar the engine over until the shaft is seated on all 4 pedestals. To bar the engine, remove the oil filter tube and use a 3/4 inch drive breaker bar with extension to rotate the engine.

**NOTE:** THE VALVE/BRAKE ROCKER LEVER SHAFTS HAVE A MACHINED FLAT ON THE FRONT END OF THE SHAFT FOR DETERMINING THE PRECISE BRAKE ROCKER LEVER POSITION. THE FRONT MOUNTING CAPSCREW FOR EACH VALVE/BRAKE ROCKER LEVER SHAFT SHOULD BE INITIALLY TIGHTENED TO 13 N-M (115 IN-LB) TO PROPERLY SEAT THE FLAT OF THE SHAFT INTO ITS MATING SADDLE.

3. Lubricate the lever shaft capscrews with clean lube oil. Install remaining capscrews with washer or solenoid manifold assemblies mount under the capscrews between cylinders 1 and 2, and also between cylinders 2 and 3. On the rear shaft the solenoid manifold assembly mounts under the capscrews between cylinders 4 and 5.
4. Tighten the front mounting capscrew for the shaft. **Torque Value** – 68 N-m (50 ft-lb) Tighten the remaining capscrews. **Torque Value** – 68 N-m (50 ft-lb)
5. Loosen the capscrews **one at a time** 360 degrees and tighten again using the torque plus angle method. Tighten capscrews from the center out to 30 N-m (22 ft-lb). Then rotate each capscrew 60 degrees.
6. Repeat this procedure for the remaining rocker shaft.

## Adjust Brake Lever Lash Setting



TO GET MAXIMUM BRAKE OPERATING EFFICIENCY AND TO PREVENT ENGINE DAMAGE, YOU MUST FOLLOW THE INSTRUCTIONS IN THIS SECTION.

1. The engine brake setting is to be made in the same sequence as the firing order **(1, 5, 3, 6, 2, 4)**.
2. Locate the engine brake set marks on the outside of the vibration damper.
3. The set marks are BRAKE SET 1-6, BRAKE SET 2-5, BRAKE SET 3-4:
  - a. "BRAKE SET 1-6": cylinder 1 or 6 adjust
  - b. "BRAKE SET 2-5": cylinder 2 or 5 adjust
  - c. "BRAKE SET 3-4": cylinder 3 or 4 adjust
4. Using a 3/4 inch drive breaker bar with extension, rotate the engine clockwise until set mark 1-6 on the vibration damper aligns with the stamped mark on the front gear cover. Check the engine brake lever on the given cylinder. When adjusting cylinder No. 1, both the intake and exhaust valves on cylinder No. 1 **must** be closed. The camshaft follower of the brake lever **must** be on the inner base circle of the valve camshaft lobe. If not, rotate the engine one full revolution to set mark 1-6.
5. Press the engine brake lever down to position the lever camshaft follower in contact with the camshaft.
6. Loosen the locknut on the brake lever adjusting screw, and back out the adjusting screw one turn.
7. Set lash 7.0mm by inserting the feeler gage part no. 3163530 between the bottom of the engine brake actuator piston (12) and the top of the exhaust valve guide pin on the exhaust valve crosshead.
8. Tighten the adjusting screw until drag on the feeler gage is felt. Proper drag means that there is no motion of the brake lever camshaft follower against the cam lobe.
9. Hold the engine brake lever adjusting screw and tighten the locknut 20N-m (15 ft-lb).
10. Repeat the procedure with the remaining cylinders.
11. Replace the oil filler tube.



FOR THE MAXIMUM DURABILITY OF THE BRAKE ASSEMBLY, CHECK THE RUNNING CLEARANCES BETWEEN THE ACTUATOR PISTON AND THE EXHAUST VALVE CROSSHEAD GUIDE PIN. WITH THE BRAKE ROCKER LEVER IN THE NEUTRAL POSITION, A.020" FEELER GAGE BLADE MUST PASS FREELY BETWEEN THE ACTUATOR PISTON AND THE GUIDE PIN. IF NOT, LOOSEN THE SHAFT ASSEMBLY AND ROTATE THE SHAFT IN THE DIRECTION NECESSARY TO INCREASE THE RUNNING CLEARANCES. RETORQUE THE SHAFT ASSEMBLY AS DESCRIBED ABOVE. (DESIRED CLEARANCE = .060").

## Type-I Solenoid Seal Removal and Replacement (Threaded Body)

1. Remove the solenoid (1) using a 3/4" socket and discard three solenoid seals.
2. Dip the seals in oil. Install the upper and center seal (2, 3) on the solenoid. Coat the inside of the manifold with oil. Place the lower seals (4) in the bottom of the manifold. The oil will keep the seals from being twisted and/or cut during installation of the solenoid into the manifold. Install the solenoid into the manifold. Tighten the solenoid to 20 N-m (15 ft-lb) using a 3/4" socket.
3. Install the wiring harness support bracket into the cylinder head.
4. Connect the wiring harness terminals to the solenoid terminals.

## Type-II Solenoid O-Ring Removal and Replacement - (Push-In)

1. Remove the solenoid (1) using a 5mm hex socket and discard two solenoid o-rings.
2. Install the upper (14) and lower (13) o-ring on the solenoid. Coat the o-rings with oil. Install the solenoid into the manifold (5). Align the clamp with manifold thread hole and install socket screw. Tighten screw to 14 N-m (124 lb-in) using 5mm hex socket.
3. Connect wiring harness nut-terminal to the solenoid thread studs. Tighten nut terminal to 1.5 N-m (13 lb-in).

## Replace Rocker Lever Valve Cover

1. Install the rocker lever cover gasket onto the rocker lever cover.
2. Install the rocker lever cover, eight capscrews, and isolator assemblies. Tighten capscrews to 25 N-m (18 ft-lb).