



Installation Manual

Cummins **Onan**

Performance you rely on.™



RV Generator Set
Microlite™ 2800 Series
KV (Spec A–M)

**WARNING:**

The engine exhaust from this product contains chemicals known to the State of California to cause cancer, birth defects or other reproductive harm.

**WARNING**

Do not use this genset on a boat
Such use may violate U. S. Coast Guard regulations and can result in severe personal injury or death from fire, electrocution, or carbon monoxide poisoning



Table of Contents

SECTION	TITLE	PAGE
	Safety Precautions	iii
	General Precautions	iii
	Generator Voltage is Deadly!	iii
	Battery Gas is Explosive	iv
	Moving Parts Can Cause Severe Personal Injury or Death	iv
	Engine Exhaust is Deadly!	iv
	The Hazards of Carbon Monoxide	iv
	Only You Can Protect Yourself From CO Poisoning!	iv
	Substances Hazardous to Health	iv
	Fuel Is Flammable and Explosive	iv
	Propane	iv
	Hazardous Reactions	v
	Protective Measures	v
	Storage/Transport	v
	Emergency Action	v
	Petrol (UK) / Gasoline	vi
	Hazardous Reactions	vi
	Protective Measures	vi
	Storage/Transport	vi
	Emergency Action	vi
	Lubrication Oil – Premium Blue E 15W40	vii
	Hazardous Reactions	vii
	Protective Measures	vii
	Storage/Transport	vii
	Generator Set Warning Labels	viii
1	Introduction	1-1
	General	1-1
	Installation Codes and Safety Recommendations	1-1
	Component Locations	1-2
2	Specifications	2-1
3	Step-By-Step Installation Outline	3-1
	Introduction	3-1
	Preparation	3-1
	Compartment Mounting	3-2
	Under-Floor Mounting	3-3
	Connecting to Vehicle Systems	3-5
	Exhaust Systems	3-7
4	Mounting	4-1
	General	4-1
	Compartment Mount	4-1
	Under-Floor Mount	4-4

SECTION	TITLE	PAGE
5	Ventilation and Acoustics	5-1
	General	5-1
	Acoustics	5-2
6	Exhaust System	6-1
	General	6-1
	Muffler Recommendations	6-1
	Exhaust Installation Guidelines	6-1
	Tailpipe Recommendations	6-3
7	Fuel System	7-1
	General	7-1
	Gasoline Fuel System	7-1
	Evaporative System Installation	7-4
	LPG Fuel System	7-8
8	Electrical Connections	8-1
	General	8-1
	AC Wiring	8-1
	DC Wiring	8-5
	Batteries	8-6
9	Initial Start and Checks	9-1
	Installation Review	9-1
	Pre-start Checks	9-2
	Initial Starting and Checks	9-3

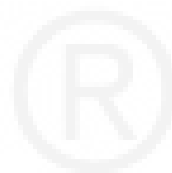

Safety Precautions

Thoroughly read the OPERATOR'S MANUAL before operating the genset. Safe operation and top performance can be obtained only when equipment is operated and maintained properly.

Only trained and experienced service personnel with knowledge of fuels, electricity, and machinery hazards shall remove, dismantle and dispose of the generator set. See Service manual.

Some generator set installation procedures present hazards that can result in severe personal injury or death. Only trained and experienced personnel with knowledge of fuels, electricity, and machinery hazards should perform generator set installation procedures.

The following symbols in this manual alert you to potential hazards to the operator, service person and equipment.

⚠ DANGER *Used to alert you to a lethal hazard against which you must take steps to prevent severe personal injury or death, as when you are in the vicinity of High Voltage equipment.*

⚠ WARNING *Used to alert you to a hazard or unsafe practice which can result in severe personal injury or death.*

⚠ CAUTION *Used to alert you to a hazard or unsafe practice which can result in personal injury or equipment damage.*

Electricity, fuel, exhaust, moving parts and batteries present hazards which can result in severe personal injury or death.

GENERAL PRECAUTIONS

- Keep fire extinguishers handy.
- Make sure all fasteners are secure and torqued properly.
- Keep the genset and its compartment clean. Excess oil and oily rags can catch fire. Dirt and

gear stowed in the compartment can restrict cooling air.

- Before working on the genset, disconnect the negative (-) battery cable at the battery to prevent starting.
- Use caution when making adjustments while the genset is running—hot, moving or electrically live parts can cause severe personal injury or death.
- Used engine oil has been identified by some state and federal agencies as causing cancer or reproductive toxicity. Do not ingest, inhale, or contact used oil or its vapors.
- Benzene and lead in some gasolines have been identified by some state and federal agencies as causing cancer or reproductive toxicity. Do not to ingest, inhale or contact gasoline or its vapors.
- Do not work on the genset when mentally or physically fatigued or after consuming alcohol or drugs.
- Carefully follow all applicable local, state and federal codes.
- Use personal protective equipment when performing maintenance operations such as glasses, gloves, etc.

GENERATOR VOLTAGE IS DEADLY!

- Generator output connections must be made by a qualified electrician in accordance with applicable codes.
- The genset must not be connected to the public utility or any other source of electrical power. Connection could lead to electrocution of utility workers and damage to equipment. An approved switching device must be used to prevent interconnections.
- Use caution when working on live electrical equipment. Remove jewelry, make sure clothing and shoes are dry and stand on a dry wooden platform.

BATTERY GAS IS EXPLOSIVE

- Wear splash-proof safety glasses.
- Do not smoke or permit flames or sparks to occur near the battery at any time.
- To reduce arcing when disconnecting or reconnecting battery cables, always disconnect the negative (-) battery cable first and reconnect it last.

MOVING PARTS CAN CAUSE SEVERE PERSONAL INJURY OR DEATH

- Do not wear loose clothing or jewelry near moving parts such as PTO shafts, fans, belts and pulleys.
- Keep hands away from moving parts.
- Keep guards in place over fans, belts, pulleys, etc.

ENGINE EXHAUST IS DEADLY!

- Learn the symptoms of carbon monoxide poisoning in this manual and never occupy the vehicle while the genset is running unless the vehicle is equipped with a working carbon monoxide detector.
- Prior to every startup and after every eight hours of running, all carbon monoxide detectors must be tested and confirmed to be working in accordance with the manufacturer's instructions or owners manual.
- The exhaust system must be installed in accordance with the genset Installation Manual. Engine cooling air must not be used for heating the working or living space or compartment.
- Inspect for exhaust leaks at every startup and after every eight hours of running.
- Make sure there is ample fresh air when operating the genset in a confined area.

THE HAZARDS OF CARBON MONOXIDE

Engine-driven generators can produce harmful level of carbon monoxide that can injure or kill you.

ONLY YOU CAN PROTECT YOURSELF FROM CO POISONING!

- Watch constantly for people near the exhaust of the generator set while it is running.

- Make sure exhaust cannot enter the living quarters through a window, vent or door.
- Make sure all CO detectors or audible alarms are working properly.
- Pay attention to the signs of CO poisoning.

SUBSTANCES HAZARDOUS TO HEALTH

Generator sets use substances, and emit and create wastes that can cause health risks. Generator set operators must use appropriate personal protective equipment (such as clothing, gloves, protective glasses/goggles, and respiration equipment) when exposed to fuel, oil, coolant, wet batteries, grease, cleaning agents, or other substances exposed to lungs, eyes, or skin. Use appropriate containers for transport, storage, and disposal of waste substances. Follow local regulations for disposal and recycling.

FUEL IS FLAMMABLE AND EXPLOSIVE

- Do not smoke or turn electrical switches ON or OFF where fuel fumes are present or in areas sharing ventilation with fuel tanks or equipment. Keep flame, sparks, pilot lights, arc-producing equipment and switches and all other sources of ignition well away.
- Fuel lines must be secured, free of leaks and separated or shielded from electrical wiring.
- Leaks can lead to explosive accumulations of gas. Natural gas rises when released and can accumulate under hoods and inside housings and buildings. LPG sinks when released and can accumulate inside housings and basements and other below-grade spaces. Prevent leaks and the accumulation of gas.

PROPANE

This product is also known as C₃H₈ or liquified propane gas. It consists of predominantly C₃ Hydrocarbons (propane and prepane) with typically < 50 ppm of ethyl mercaptan or other odorizing agent added to assist leak detection. Contains <0.1% 1, 3 butadiene. Hazardous components include c3-4 rich, petroleum distillate.

The substance has an initial boiling point of -42.1°C flash point of -104°C (PMCC), and a vapor pressure of 7.5 bar at 15°C .

Keep the container below 50°C . The substance should not be used for any other purpose without contacting the manufacture or supplier. Installers, operators and maintainers are likely to encounter this substance. When doubt exists as to correct handling procedure, contact supplier.

HAZARDOUS REACTIONS

This liquid is extremely flammable (F+). Readily forms an explosive air-vapor mixture at ambient temps. Avoid smoking, heat sources, such as welding and naked flames, sparks and static electricity build-up. Thermal decomposition products are hazardous, containing CO_x compounds.

The vapor is explosive. High vapor concentrations can cause respiratory irritation, dizziness, nausea, and loss of consciousness. Excessive and prolonged exposure to the mist can cause chronic inflammatory reaction of the lungs and form of pulmonary fibrosis.

Vapor is heavier than air and may travel to remote sources of ignition. Liquid leaks generate large volumes of flammable vapor (approx 250:1).

Avoid strong oxidizing agents, e.g. chlorates which may be used in agriculture

Cold burns (frost bite) will result from skin/eye contact with liquid. Toxicity following single exposure to high level of propane is of low order.

PROTECTIVE MEASURES

Ensure good ventilation and avoid heat sources. Observance of good housekeeping rules will ensure general safety. Do not smoke.

When working on, or testing, injection equipment, special care is required. Use eye protection at all times.

Adopt a high standard of personal hygiene. In the case of skin contact, flush with water to normalize temperature. Use gloves and overalls, and eye protection goggles. Use oil impervious gloves and avoid contamination inside the gloves. If overalls become contaminated, discontinue use and clean thoroughly. Contaminated clothing should be re-

moved, soaked with water, and laundered before reuse.

STORAGE/TRANSPORT

Store and transport only in correctly marked containers. Keep containers closed when not in use. Keep cool, out of sunlight and away from naked flames. Electrical continuity is required between the transport and storage vessels during product transfer.

In case of leak clear people away from area to a safe place. DO NOT operate electrical equipment unless flame proof. Summon emergency services and treat or refer casualties as necessary.

Extinguish all naked lights – AVOID MAKING SPARKS! Try to stop flow of product. Cover drains and dispense vapor with water spray. Note: Vapor may collect in confined spaces.

EMERGENCY ACTION

- Fire
Extinguishing media:
Large fire – None. Product flow must be stopped and container cooled by water spray. Water fog should be used to assist approach to source of the fire.
Small fire – foam/dry powder, CO_2
Avoid making sparks. Fire fighters to sue self-contained breathing apparatus. Keep fire exposed containers cool, using water fog/spray. Prevent run-off from entering waterway, drains and drinking water supplies. Every precaution must be taken to keep containers cool to avoid the possibility of a boiling liquid expanding vapor explosion (BLEVE).
- Ingestion: Not applicable
- Inhalation (of vapor)
Remove from further exposure. Obtain medical assistance immediately.
- Eyes
Cold burns should be flushed with water to normalize temperature. Cover burns with sterile dressings. Do not use ointments or powders. Obtain medical assistance as necessary.
- Skin
Cold burns should be flushed with water to normalize temperature. Cover burns with sterile dressings. Do not use ointments or powders. Obtain medical assistance as necessary.
- Spillage: See Storage/Transport

PETROL (UK) / GASOLINE

This product is also known as petrol (UK) or gasoline. It can be clear liquid with slight tan or yellow color with a characteristic mild odor. It is a complex combination of hydrocarbons consisting of primarily of paraffins, naphthenes, aromatic and olefinic hydrocarbons having carbon numbers predominantly between C4 and C12.

The substance has an initial boiling point of 25–220°C, a flash point greater than $<-40^{\circ}\text{C}$, and a vapor pressure between 0.5 – 1 bars and has negligible solubility in water.

It is used as a fuel for off-road petrol powered vehicles and stationary engines, and can be found in fuel tanks, pipes and injection systems. The substance should not be used for any other purpose without contacting the manufacturer or supplier. Installers, operators and maintainers are likely to encounter this substance.

HAZARDOUS REACTIONS

This liquid is extremely flammable. Avoid smoking, heat sources, such as welding and naked flames, sparks and static electricity build-up. Thermal decomposition products are hazardous, containing CO_x , NO_x and SO_x compounds.

The vapor is explosive. High vapor concentrations can result in central nervous system and respiratory depression with subsequent loss of consciousness. Where ventilation is poor or temperature high, vapor production may be a hazard. Excessive and prolonged exposure to the mist can cause chronic inflammatory reaction of the lungs and form of pulmonary fibrosis.

Avoid strong oxidizing agents, e.g. chlorates which may be used in agriculture.

Petrol is slightly irritating to the skin and has a defatting action. Toxicity following single exposure to high level of petrol is of low order. Prolonged, repeated skin contact may de-fat the skin resulting in possible skin irritation and dermatitis. In some cases warty, cancerous growths have occurred. This product contains benzene ($<1\%$) which is classified as a carcinogen. Exposure to Benzene may result in blood disorders such as anaemia and leukemia. Toxic to aquatic organisms, may cause long-term adverse effects in aquatic environment.

PROTECTIVE MEASURES

Ensure good ventilation and avoid heat sources. Observance of good housekeeping rules will ensure general safety. Do not smoke. Avoid breathing mist.

When working on, or testing, injection equipment, special care is required to avoid perforation of skin by high pressure fuel. Use eye protection in the event of suspected high pressure leak.

Adopt a high standard of personal hygiene. In the case of skin contact, wash well with soap and water.

Use glove and overalls, and eye protection goggles if there is a risk of splashing. Use oil impervious gloves and avoid contamination inside the gloves. If overalls become contaminated, discontinue use and clean thoroughly. Contaminated clothing should be removed, soaked with water, and laundered before use.

No special respiratory precautions are necessary in normal use.

DO NOT use as a solvent for removing dirt/grease etc., from skin.

STORAGE/TRANSPORT

Store and transport only in correctly marked containers. Keep containers closed when not in use. Keep cool, out of sunlight and away from naked flames. Electrical continuity is required between the transport and storage vessels during product transfer.

Contain leak/spill with sand, earth or other suitable material, and prevent entry of substance into drainage/sewerage system, water-courses and land. Dispose of unwanted or absorbed substance through unauthorized contractor to a licensed site.

Inform local and fire authorities should the product reach waterways, drains etc.

EMERGENCY ACTION

- Fire
Extinguishing media:
Large fire – Foam/water fog. Never use water jet.
Small fire – foam/dry powder, AAF, CO_2 , sand, earth.
Avoid making sparks. Fire fighters to use self-contained breathing apparatus. Keep fire exposed containers cool, using water fog/spray.

Prevent run-off from entering waterway, drains and drinking water supplies.

- Ingestion
Do not induce vomiting. Wash the mouth out with water, and send to hospital immediately.
- Inhalation (of vapor)
Remove from further exposure. Obtain medical assistance immediately.
- Aspiration (inhalation of liquid)
If, following ingestion of gas oil, vomiting occurs, there is danger of aspiration into the lungs. This would cause intense local irritation and chemical pneumonitis that can be fatal. Obtain immediate medical assistance.
- Eyes
Irrigate copiously with water or preferably eye-wash solution for at least five minutes. If irritation persists seek medical advice.
- Skin
Wash thoroughly with soap and water. Change clothing if necessary.
If high pressure injection has occurred prompt surgical attention is required.
- Spillage
Absorb using sand, earth or other suitable material. Dispose of unwanted or absorbed flammable material as directed under Storage/Transport (Section 5.7.3). In the event of a major spillage, only trained personnel wearing self contained breathing apparatus should handle the spill. Any spillage or leak should be treated as a major fire/explosion hazard. If vehicles present, switch off engines.

LUBRICATION OIL – PREMIUM BLUE E 15W40

Also known as oil, lube oil, sump oil, new oil is dark, viscous liquid with a slight, characteristic odor. The base oil contains: distillates (petroleum), solvent-dewaxed heavy paraffinic. It is not classified as dangerous according to Directive 1999/45/EC and its amendments, and is not classified according to the EU regulations.

It has a boiling point greater than 150°C, a flash point Open Cup of 220°C (Cleveland), and is insoluble in cold water.

It is used in engine lubricant oil systems, sump pan and filters, make-up tanks and piping systems as a

lubrication oil for use in wide range of diesel engines operating under severe conditions. Installers, operators and maintainers are likely to encounter this product.

HAZARDOUS REACTIONS

This product is stable although slightly re-active with oxidizing agents. Results of decomposition are carbon oxides (CO, CO₂) and water.

Although harmful if swallowed or aspirated (breathed in), repeated or prolonged exposure is not known to aggravate medical conditions.

Used oil may contain harmful combustion by-products and unburnt fuel that will cause skin reactions as detailed for fuel. Particular care must be taken if oil from a severely overheated engine is handled – use impervious gloves, lab coat and safety glasses.

Do not breathe vapor/spray.

PROTECTIVE MEASURES

Ensure good ventilation and avoid heat sources.

Adopt a high standard of personal hygiene. In case of skin contact, wash thoroughly with soap and water.

Use safety glasses, impervious gloves and lab coat. Avoid contamination inside the gloves. If overalls become contaminated, discontinue use and clean thoroughly.

No special respiratory precautions are necessary in normal use. Do not breathe vapor/spray when handling hot materials.

STORAGE/TRANSPORT







Store and transport only in correctly marked containers. Keep containers tightly sealed when not in use. Keep in cool, well ventilated area, out of sunlight and away from naked flames. Store well away from food – stuffs and drinking water.

Wear splash goggles, full suit, boots and gloves. Absorb leak/spill with inert material and dispose of unwanted or absorbed substance through an authorized contractor to a licensed site. Finish cleaning by spreading water on the contaminated surface and allow to evacuate through the sanitary system.

GENERATOR SET WARNING LABELS

Warning signs are provided on the generator set at or near the point of risk. To avoid injury, always take

the necessary precautions – as indicated on the sample signs shown below.

	Caution / Warning. Indicates a risk of personal injury.
	Caution / Warning of Temperature Hazard. Indicates a risk of personal injury from high temperature.
	Caution / Warning of High Voltage Hazard. Indicates a risk of personal injury from electric shock/electrocution.
	Caution / Warning. Indicates a risk of personal injury from equipment that may be subject to automatic starting or remote starting.
	Caution / Warning. Indicates to read Operator manual for additional information.
	Caution / Warning of Belt and Rotating Part Hazard. Indicates a risk of personal injury from entanglement in moving parts.
	Caution / Warning of Pressure Hazard. Indicates a risk of personal injury from pressurized fluids.



1. Introduction

GENERAL

This manual provides installation guidelines for the MicroLite™ (KV) generator set (referred to as genset). The genset must be installed properly to operate reliably, quietly, and safely. Read this entire manual before starting the installation.

For operation and maintenance procedures, see the Operator's Manual (981-0136) that accompanies each genset.

When properly installed, this genset meets or exceeds the following requirements:

- National Electrical Code, NFPA 70-Article 551
- ANSI/RVIA EGS-1 - 1986, Generator Set standard
- ANSI A119.2/NFPA 501C Standard for Recreational Vehicles
- NFPA 58 Standard for the Storage and Handling of Liquefied Petroleum Gases
- CSA Electrical Bulletin 946

The RV manufacturer and/or the genset installer must comply with local codes such as California administrative Code title 25, which applies to genset installation. The RV installer bears sole responsibility for the selection of the appropriate genset, installation design, and installation.

Consider the following requirements before installing the genset. Each topic is covered in the following text.

- Level and supportive mounting surface
- Adequate cooling air
- Adequate fresh induction air
- Discharge of circulated air
- Noise levels
- Accessibility for maintenance and service
- Exhaust connections
- Fuel supply
- Electrical connections

MicroLite is a trademark of the Onan Corporation.

INSTALLATION CODES AND SAFETY RECOMMENDATIONS

The following list of Installation Codes and Safety Recommendations applies to the installation and operation of RV gensets. The address of each agency is listed so that copies of the codes may be obtained for reference. Installation codes and recommendations are subject to change, and may vary by location or over time. The RV manufacturer and the genset installer bear sole responsibility for following all applicable codes and regulations.

- | | |
|---|---|
| 1. ANSI-A119.2
FMVSS 301 | Recreational Vehicle
Industry Association
14650 Lee Road
Chantilly, VA 22021 |
| 2. NFPA 70 (N.E.C.)
NFPA 501C
NFPA 58 | National Fire Protection
Association
470 Atlantic Avenue
Boston, MA 02210 |
| 3. CSA Electrical
Bulletin #946 | Canadian Standards
Association, Housing and
Construction Materials
Section
178 Rexdale Blvd.
Rexdale, Ontario,
Canada M9W 1R3 |
| 4. California
Administrative
Code - Title 25
Chapter 3 | State of California
Documents Section
P.O. Box 1015
North Highlands, CA
95660 |

This manual contains information that is subject to change. For this reason, use only the installation manual supplied with the genset for the installation.

Keep this manual along with the Operator's manual in the RV or near the genset for future reference.

⚠ *WARNING* Incorrect installation, service, or replacement of parts can result in severe personal injury, death and/or equipment damage. Service personnel must be qualified to perform electrical and/or mechanical component installation.

⚠️WARNING *This genset is not a life support system. It can stop without warning. Children, persons with physical or mental limitations, and pets could suffer personal injury or death. A personal attendant, redundant power or an alarm system must be used if genset operation is critical.*

⚠️WARNING *This generator set is not "ignition protected" and shall not be used in a flammable vapor environment.*

To remove the access cover: Slide the latches up and pull the cover outward from the bottom. Lower the cover to remove it from the housing.

To secure the access cover: Position the tabs on the top of the access cover in the openings on the housing. Slide the latches up and push the bottom of the cover in place. Hold the cover in place firmly while releasing the latches to secure the cover.

⚠️WARNING *Operation of the genset with the access cover removed can result in severe personal injury or equipment damage. Hot components are exposed when the access cover is removed and genset cooling air does not circulate properly. Do not operate the genset with the access cover removed.*

COMPONENT LOCATIONS

The standard control panel and routine maintenance items are located behind the access cover (Figure 1-1).

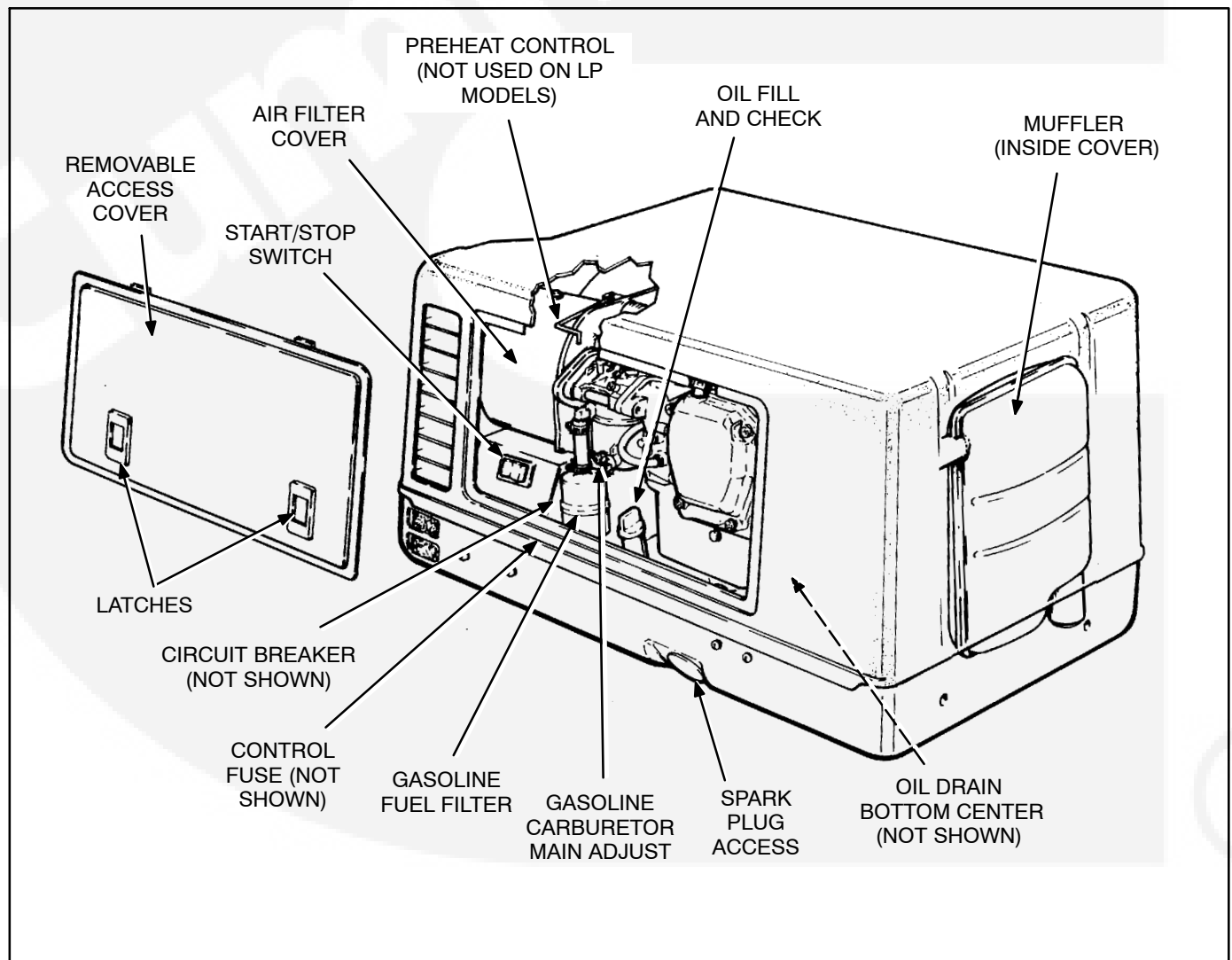

FIGURE 1-1. MICROLITE KV COMPONENT LOCATIONS

2. Specifications

TABLE 2-1. SPECIFICATIONS FOR GASOLINE-FUELED MODELS

	MODEL 2.3 KV	MODEL 2.8 KV
GENERATOR: 2-Pole Revolving Field, Self-Excited, Electronically Regulated, 1-Phase		
Power	2,300 watts	2,800 watts
Frequency	50 Hertz	60 Hertz*
Voltage	230 volts	120 volts
Current	10.0 amperes	23.3 amperes
Speed	3,000 RPM	3,600RPM
FUEL CONSUMPTION: Gasoline		
No load gph (l/h)	0.20 (0.8)	0.20 (0.8)
Half load gph (l/h)	0.23 (0.9)	0.30 (1.1)
Full load gph (l/h)	0.40 (1.5)	0.43 (1.6)
ENGINE: 1-Cylinder, 4-Cycle, Spark-Ignited, OHV, Air Cooled		
Bore	2.64 inches (67 mm)	
Stroke	2.2 inches (56 mm)	
Displacement	12 inches ³ (197 cc)	
Compression Ratio	8.5 : 1	
Oil Capacity**	1 quart (0.95 l)	
Intake Valve Clearance (Cold)	0.002 inches (0.05 mm)	
Exhaust Valve Clearance (Cold)	0.002 inches (0.05 mm)	
Spark Plug Gap	0.025 inches (0.64 mm)	
Spark Plug Tightening Torque	13 lbs-ft (17 N-m)	
Ignition Timing (Breakerless electronic magneto ignition)	25° BTDC, non-adjustable	
CONTROL AND CRANKING SYSTEM: 12 VDC		
Nominal Battery Voltage	12 volts	
Minimum Required Battery Cold Cranking Capacity (amperes)	360	
Control Fuse	5 amp	
* – The 60 Hertz models are Listed by CSA and the U.S. Testing Company.		
** – See <i>Periodic Maintenance</i> for oil filling instructions.		

TABLE 2-2. SPECIFICATIONS FOR LPG-FUELED MODELS

	MODEL 2.0 KV	MODEL 2.5 KV
GENERATOR: 2-Pole Revolving Field, Self-Excited, Electronically Regulated, 1-Phase		
Power	2,000 watts	2,500 watts
Frequency	50 Hertz	60 Hertz*
Voltage	230 volts	120 volts
Current	8.7 amperes	20.8 amperes
Speed	3,000 RPM	3,600RPM
FUEL CONSUMPTION: LPG		
No load gph (l/h)	0.20 (0.8)	0.20 (0.8)
Half load gph (l/h)	0.30 (1.14)	0.34 (1.29)
Full load gph (l/h)	0.45 (1.7)	0.55 (2.08)
ENGINE: 1-Cylinder, 4-Cycle, Spark-Ignited, OHV, Air Cooled		
Bore	2.64 inches (67 mm)	
Stroke	2.2 inches (56 mm)	
Displacement	12 inches ³ (197 cc)	
Compression Ratio	8.5 : 1	
Oil Capacity**	1 quart (0.95 l)	
Intake Valve Clearance (Cold)	0.002 inches (0.05 mm)	
Exhaust Valve Clearance (Cold)	0.002 inches (0.05 mm)	
Spark Plug Gap	0.025 inches (0.64 mm)	
Spark Plug Tightening Torque	13 lbs-ft (17 N-m)	
Ignition Timing (Breakerless electronic magneto ignition)	25° BTDC, non-adjustable	
CONTROL AND CRANKING SYSTEM: 12 VDC		
Nominal Battery Voltage	12 volts	
Minimum Required Battery Cold Cranking Capacity (amperes)	360	
Control Fuse	5 amp	
* – The 60 Hertz models are Listed by CSA and the U.S. Testing Company.		
** –See <i>Periodic Maintenance</i> for oil filling instructions.		

3. Step-By-Step Installation Outline

INTRODUCTION

This section provides a step-by-step overview of a typical installation. This section includes:

- Preparation
- Compartment Mounting
- Under-Floor Mounting
- Connecting to Vehicle Systems
- Exhaust System

Review this section, then refer to the detailed instructions in sections four through nine for specific procedures and important safety precautions. The installer is responsible for complying with all applicable installation codes and safety requirements.

PREPARATION

1. Remove the shipping carton by cutting the banding around the bottom. Unfold the flaps at the bottom of the carton and lift the carton off the genset.

Collect all loose shipped items, like the Operator's Manual, and add them to the vehicle documentation package.

⚠ CAUTION *This genset contains oil. Do not tip the genset over or oil leakage and genset damage can result.*

2. Remove the shipping bolts that secure the wooden skid to the ends of the genset base.

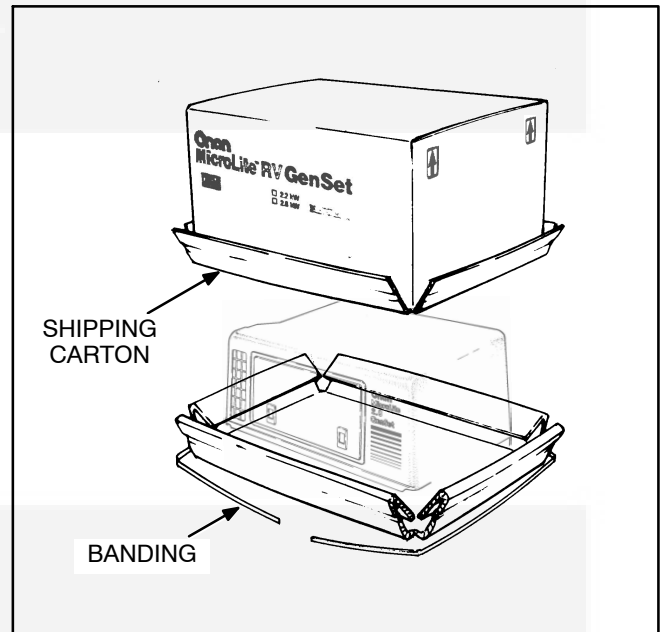

FIGURE 3-1. CRATE REMOVAL

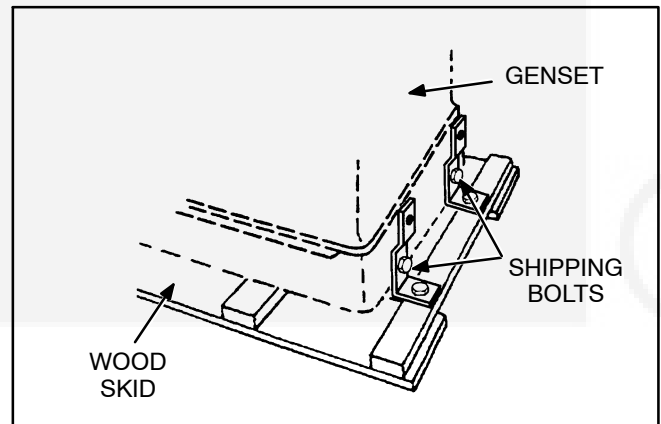

FIGURE 3-2. SKID BASE REMOVAL

COMPARTMENT MOUNTING

Install the genset in its own compartment. If any part of the compartment is above the vehicle floor, separate the compartment from the living quarters with vapor-tight walls. Refer to the *Mounting* section for compartment construction details.

⚠️ WARNING Exhaust gases present the hazard of severe personal injury or death. Make the compartment walls vapor tight to the interior of the vehicle to prevent exhaust fumes from entering the living quarters.

The genset requires an unobstructed air inlet of at least 24 square inches (155 cm²). Refer to the *Mounting* and *Ventilation* section for details. Provide an adequate genset access for maintenance and service removal either through the door or out the bottom (7.5 x 15 inch [190.5 x 381 mm] minimum maintenance opening).

1. Carefully measure the compartment size to make sure there will be proper clearance for the genset. Figure 3-3 shows the compartment dimensions. Add 1/2 inch (12.7 mm) to compartment depth if 1/2-inch (12.7 mm) insulation is used inside the door.

Allowing one to two inches of additional space on the left side of the compartment will make electrical and fuel connections easier.

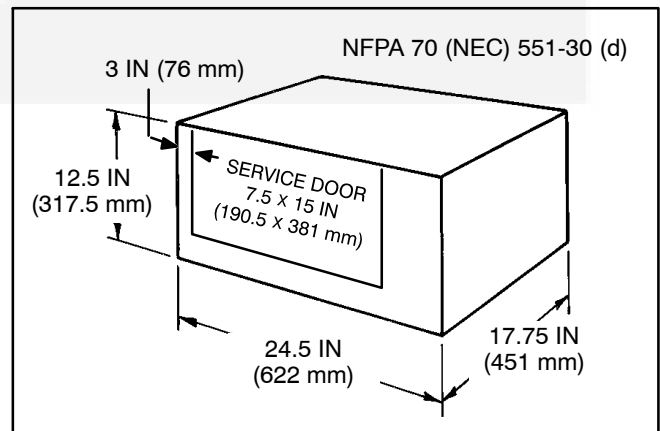

FIGURE 3-3. MINIMUM COMPARTMENT DIMENSIONS

2. Put holes in the bottom of the compartment for genset mounting, air outlet, oil drain, and spark plug access (Figure 3-4). If the bottom of the compartment is wooden, remove the wooden section under compartment and replace it with a sheet metal floor and an adequate steel support frame. (Refer to Onan template number 539-1386).

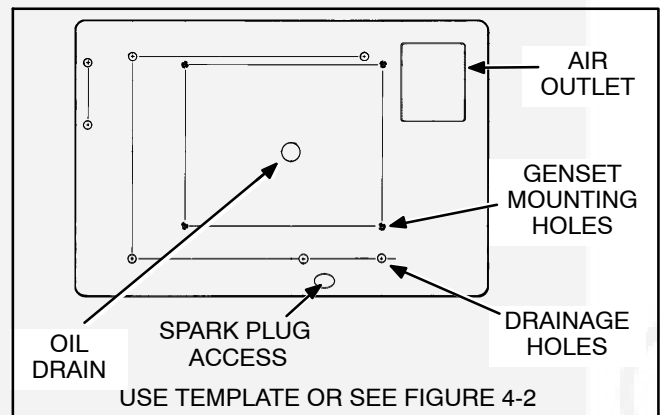

FIGURE 3-4. COMPARTMENT FLOOR TEMPLATE

- Put holes in the compartment to run connections for the fuel line, battery cable, remote control harness and AC conduit. Design holes so they will not chafe or restrict the lines.

If the remote control harness or AC conduit go directly into the interior of the vehicle, seal around and inside the conduit to prevent the passage of exhaust gases. The fuel line must not be routed through the interior of the vehicle.

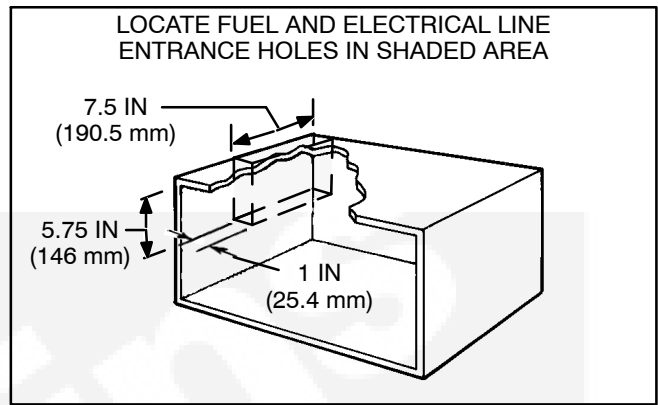

FIGURE 3-5. GENSET TO VEHICLE SYSTEMS CONNECTIONS

- Mount the genset in the compartment with four 3/8-16 screws. Screw length must not protrude more than 1/2 inch (13 mm) through the genset base.
- Proceed to Connecting To Vehicle Systems (page 3-5).

UNDER-FLOOR MOUNTING

An optional kit is required for under-floor mounting. Support brackets are used to suspend the genset below the floor of the vehicle. Refer to the instructions that are supplied with the kit for specific installation instructions and important safety precautions. For additional under-floor mounting information refer to the *Mounting* section.

- Use the template supplied with the under-floor mounting kit to locate the holes in the vehicle support structure.

⚠ WARNING *Failure to provide an adequate support structure can result in severe personal injury, death, and/or equipment damage. Carefully follow the Under-Floor Housing kit installation instructions and provide an adequate support structure. Use specified hardware and tighten all mounting hardware to the recommended torque settings.*

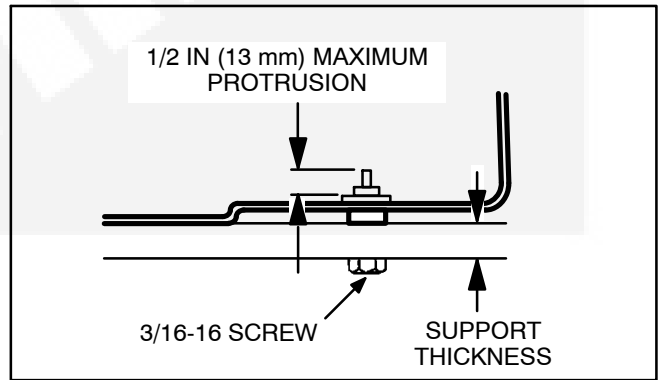

FIGURE 3-6. COMPARTMENT MOUNTING

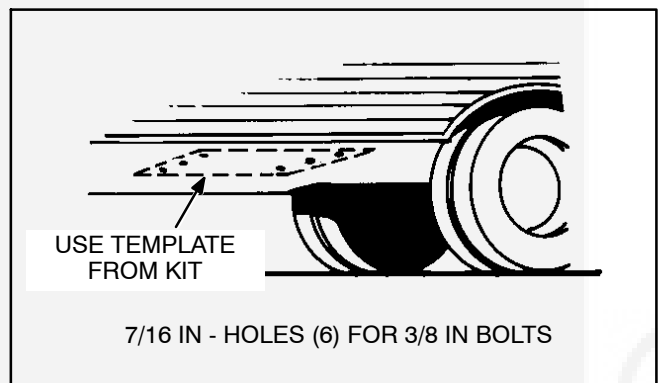

FIGURE 3-7. UNDER-FLOOR MOUNTING TEMPLATE

2. If the area above the compartment is made of a wood product, you must install a 26-gauge (0.02-inch) galvanized metal plate (or equivalent) above the genset.

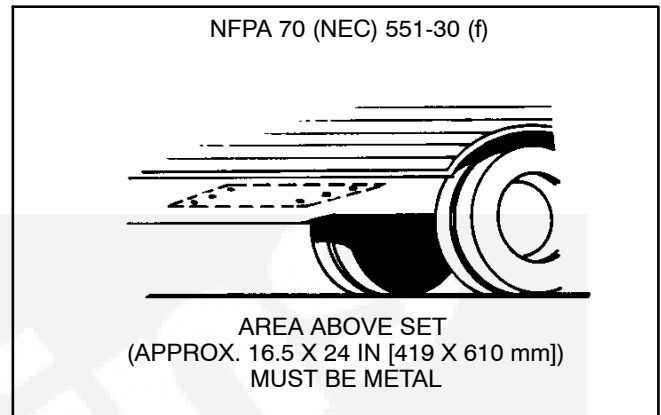

FIGURE 3-8. UNDER-FLOOR MOUNTING KIT WITH METAL CEILING (NOT SUPPLIED WITH KIT)

3. Assemble the under-floor mounting kit according to the instructions provided with the kit. Note that the side panels can be mounted with the top flanges toward the genset, as shown in Figure 3-9, or they can be reversed to point away from the genset.

⚠ WARNING *Dropping the genset can cause severe personal injury or death. Make sure no one moves the vehicle during installation by removing the keys and disconnecting the negative (-) battery cable. Keep feet and hands clear during installation.*

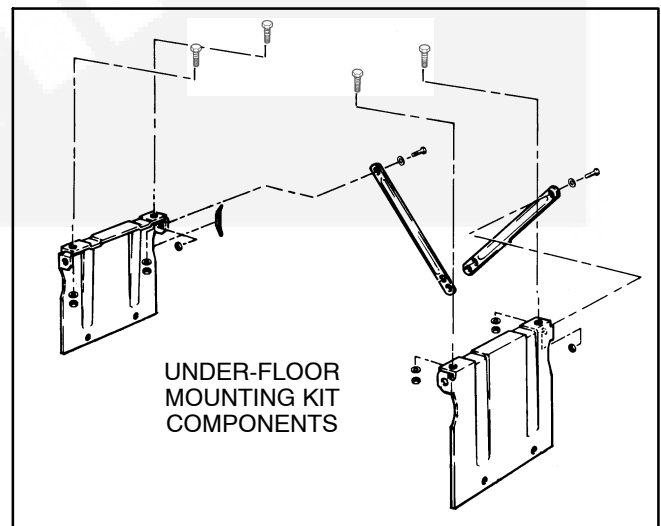

FIGURE 3-9. UNDER-FLOOR MOUNTING KIT

4. Use a forklift to carefully raise the genset into position in the support frame. Secure the genset to the support frame with the mounting hardware included in the Under-Floor Housing kit.
5. Proceed to the next section on connecting to the vehicle systems.

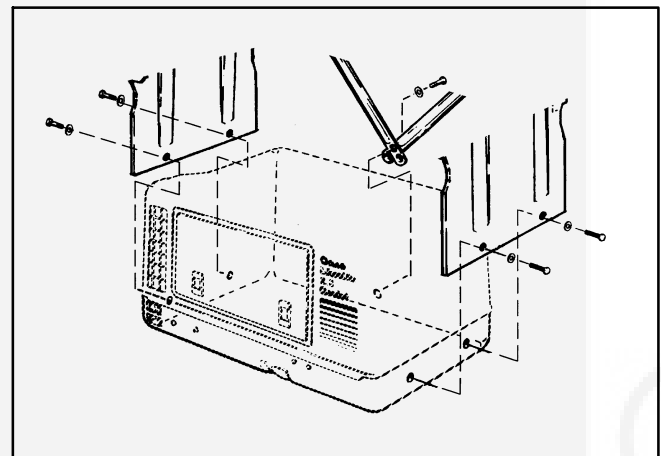

FIGURE 3-10. UNDER-FLOOR INSTALLATION

CONNECTING TO VEHICLE SYSTEMS

1. Route fuel line separate from electrical wires or separate them with conduit or other sheathing.

⚠ WARNING *Fuel presents the hazard of fire or explosion that can result in severe personal injury or death. Do not smoke or allow any flame, spark, pilot light, arc-producing equipment or other ignition sources near fuel or in the installation area. Read the important safety precautions in the Fuel Systems section.*

2. **Gasoline Fueled Sets:** Connect 1/4-inch I.D. fuel hose (type SAE 30-R7) to the barb fitting on the genset. Secure fuel hose to barb fitting with a stainless steel clamp (worm-gear type). Do not over tighten clamp or hose could be damaged.

LPG Fueled Sets: Use 1/2-inch I.D. fuel line. Use a 1/4-inch NPTF thread pipe fitting for fuel connection to the genset. LPG models are designed to operate on LP vapor at 11 inches of water column. Refer to the Fuel System section for instructions and important safety precautions.

3. Install a listed 1/2-inch flexible conduit over the AC wiring. (Use water-tight conduit for under-floor mounting.) Secure the conduit to the fitting on the genset. Make sure lines do not contact sharp, hot or abrasive surfaces.

⚠ WARNING *Accidental starting can cause severe personal injury or death. Do not connect the battery cables to the genset starting battery until instructed to in the Initial Start and Checks section.*

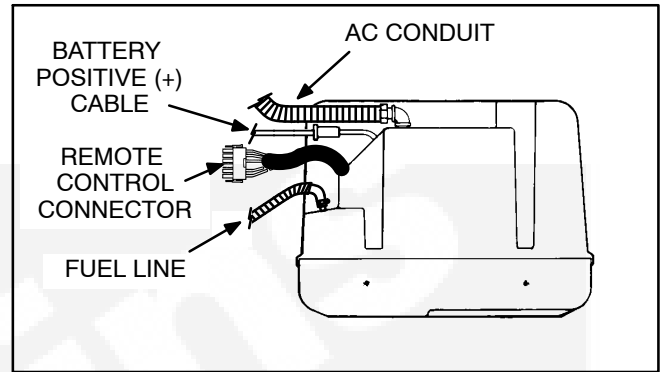

FIGURE 3-11. FUEL AND ELECTRIC LINES

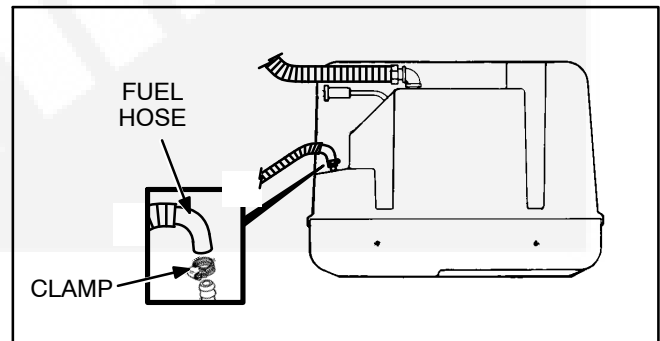

FIGURE 3-12. FUEL LINE CONNECTION

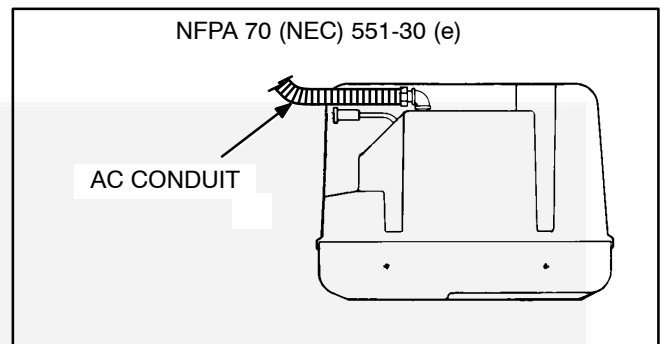

FIGURE 3-13. AC CONDUIT CONNECTION

4. Connect the battery positive (+) cable to the wiring harness B+ connection. Tighten the B+ connection securely and cover the connection with the terminal boot to insulate it. Wire-tie the terminal boot in place to prevent movement of the boot.

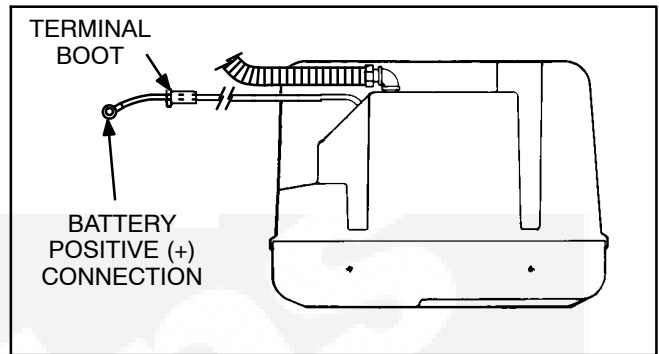

FIGURE 3-14. BATTERY POSITIVE (+) CONNECTION

5. Connect the battery negative (-) cable to any one of the four genset mounting holes in the base. Use star (EIT) washers on each side of the ring terminal when securing the terminal to base.

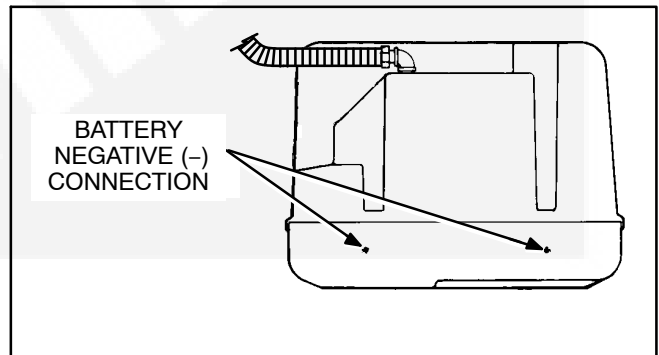

FIGURE 3-15. BATTERY NEGATIVE (-) CONNECTION

6. Connect the remote control harness connector to the mating connector on the left side of the genset (Figure 3-16).

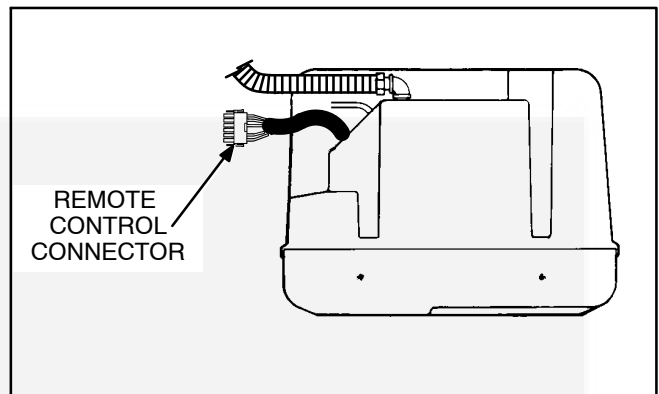

FIGURE 3-16. REMOTE CONTROL CONNECTION

7. Proceed to the next section on connecting the exhaust system.

EXHAUST SYSTEMS

Use only the Onan-specified exhaust kits. Refer to the *Exhaust* section for installation instructions and important safety precautions.

⚠ CAUTION *Failure to follow the exhaust installation guidelines can result in damage to equipment. Use the appropriate exhaust kit and install according to the instructions provided.*

1. Connect the exhaust pipe (1-1/4-inch O.D. 16-gauge aluminized or stainless steel tubing for tailpipe, installer supplied) to the genset with a U-bolt clamp.

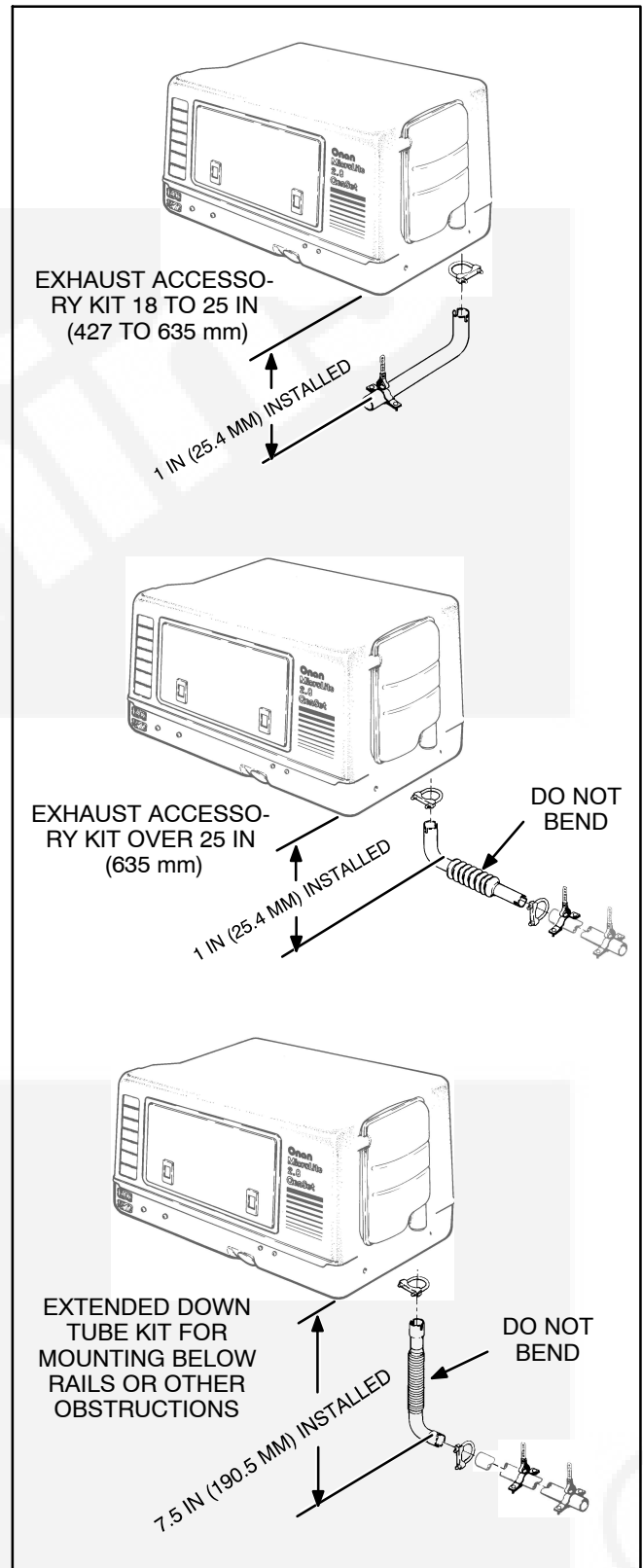

FIGURE 3-17. EXHAUST PIPE CONNECTION

⚠️ WARNING Exhaust gas presents the hazard of severe personal injury or death. Do not terminate the exhaust pipe under the vehicle. The exhaust pipe must not terminate so that any vent, window, or opening into the living area is within the arc shown in Figure 3-21. Read the important safety precautions in the Exhaust Systems section.

2. Do not terminate the exhaust tail pipe under the vehicle. The exhaust tail pipe must terminate 1 inch (25.4 mm) beyond the side or end of the vehicle.
3. Support the tail pipe as close to the outside of the vehicle as possible.

4. Protect exhaust tail pipe from impact. Do not terminate below the clearance level of the rear axle. Termination of the exhaust tail pipe below the angle of departure (lowest point on rear of vehicle to the tire ground contact point) must be protected by a skid bar, trailer hitch, or some frame member.

5. Be aware that any vent, window, or opening that can be opened and that is not permanently sealed from the vehicle living space, can be an avenue for carbon monoxide.

The tail pipe must not terminate so that any vent, window, or opening into the living area is within the shaded area shown in Figure 3-21.

6. Refer to each of the sections in this manual for detailed installation instructions and for important safety precautions. Follow the procedures in the *Initial Start and Checks* section when the installation is complete.

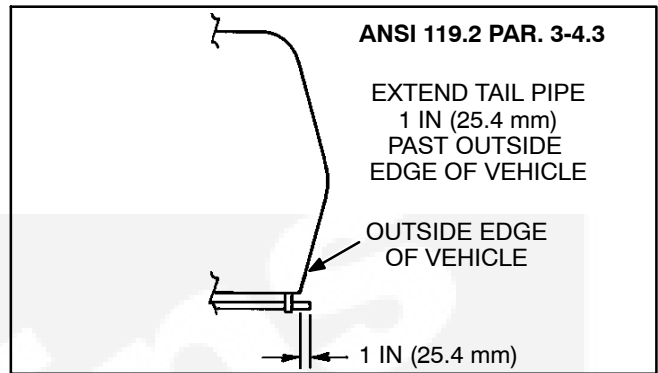

FIGURE 3-18. TAIL PIPE EXTENSION BEYOND VEHICLE

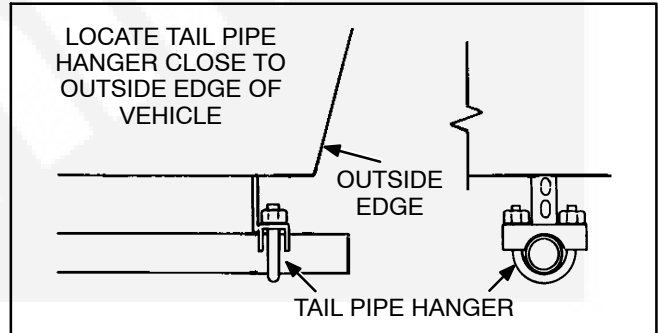

FIGURE 3-19. EXHAUST PIPE SUPPORT

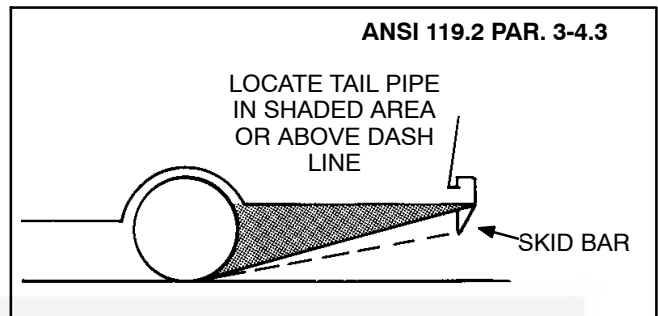

FIGURE 3-20. TAIL PIPE PROTECTION

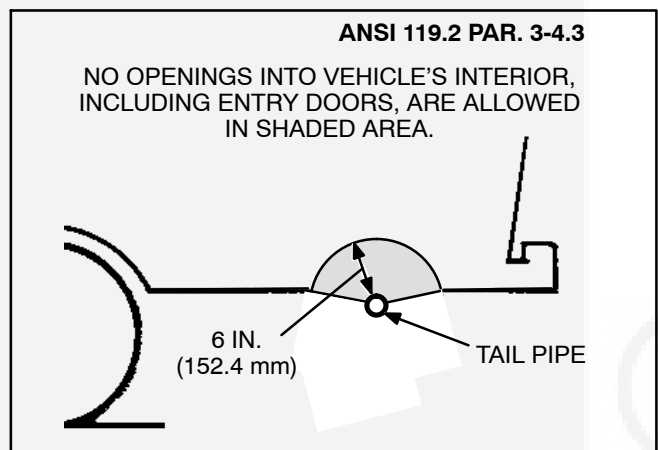

FIGURE 3-21. TAIL PIPE LOCATION

4. Mounting

GENERAL

This genset can be mounted in a compartment or in an underfloor mounting kit. Carefully follow the appropriate mounting instructions. **Read this manual and the exhaust kit and other applicable kit instructions before installing the genset.**

COMPARTMENT MOUNT

Compartment mount gensets are installed in a frame that is part of the vehicle. This frame must be constructed according to safety-approved specifications (see Compartment Construction section).

Unless the set will be removed from underneath the vehicle, make the access opening large enough to remove the set. Allow extra clearance for removal of the access cover and for spark plug removal. See Figure 1-1.

Minimum compartment dimensions are shown in Figure 4-1. Clearances between the genset and the compartment are included in these dimensions.

Allow for air intake at the service side of the set and air discharge at the bottom of the set. Air inlets to the set compartment must not allow dirt, rocks, water, or slush to reach the set. Minimize dust and salt entrance into the compartment. (See *Ventilation* section.)

Compartment Construction

1. Install the genset in its own compartment. Allow a minimum of 1 inch (25.4 mm) spacing at the front of the set and a minimum of 1/4 inch (6.4 mm) clearance on the sides, back and top of the set. See Figures 4-1 and 4-2.

Allow additional front (service side) clearance if the vehicle air inlet is not aligned with the genset air inlet, to obtain the minimum free air inlet of 24 in² (155 cm²).

Example: If the air inlet is along the bottom front edge (service side) of the compartment, increase the the front clearance by one inch (25.4 mm).

$$24 \text{ in}^2 \div 24 \text{ in (air inlet length)} = 1 \text{ inch}$$

If insulation is used to line the compartment, increase the compartment size to include the

width of the insulation. (Refer to the *Acoustics* section for insulating material specifications.)

2. If any part of the compartment is above the vehicle floor, separate the compartment area from the living quarters and fuel supply with vapor-tight walls.
3. Line the compartment walls with 26-gauge galvanized steel or a material of comparable strength and fire resistance (see NFPA 70, NEC and California Title 25 for complete details).

⚠ WARNING *Exhaust gases present the hazard of severe personal injury or death. Make the compartment walls vapor-tight to the interior of the vehicle to prevent exhaust fumes from entering the living quarters.*

4. Construct a compartment floor that will prevent oil, fuel or water accumulation. Provide openings in the compartment floor according to the Compartment Floor Plan, Figure 4-2.

Do not use absorbent soundproofing material on the compartment floor. The floor should have as few openings as possible, to reduce the noise level.

5. Equip the base with an oil drain hole to the outside of the compartment. Do not mount the exhaust pipe below the oil drain hole.

⚠ WARNING *Fire presents the hazard of severe personal injury or death. Do not position the exhaust pipe directly below a drain hole. Hot exhaust can ignite fuel or oil.*

6. Secure the genset mounting base to the support frame with four 3/8-16 UNC grade 5 screws. The mounting bolts must not extend more than 1/2 inch (13 mm) into the base. See Figures 4-1 and 4-2. Torque 3/8 inch mounting screws to 35 ft lbs (47 N•m).

⚠ CAUTION *If the mounting base is not fastened securely to the vehicle compartment, road vibrations will damage the genset components. Use screws long enough for at least 1-1/2 threads to extend through the weld nut. The mounting bolts must not extend more than 1/2 inch (13 mm) into the base.*

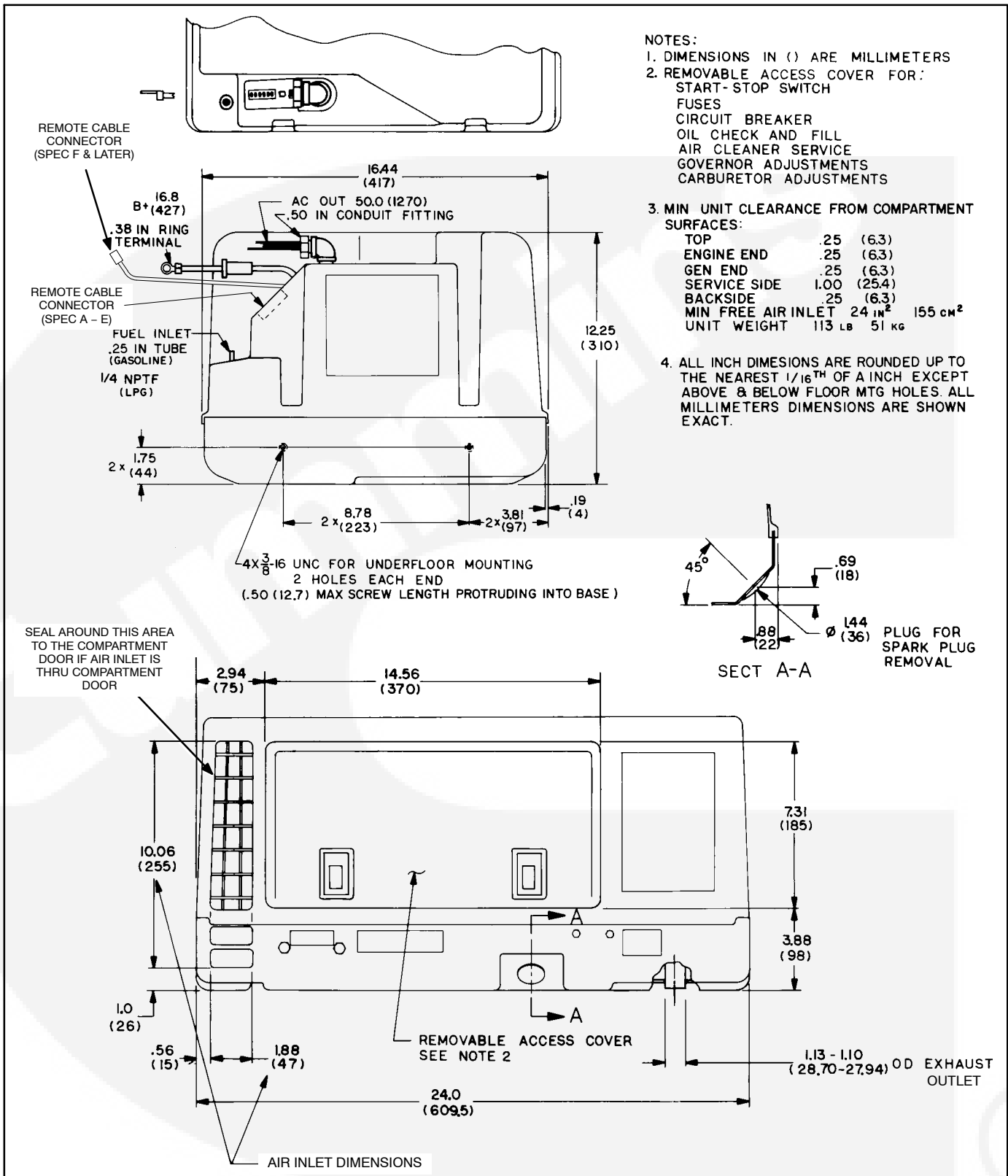

FIGURE 4-1. COMPARTMENT MOUNT OUTLINE

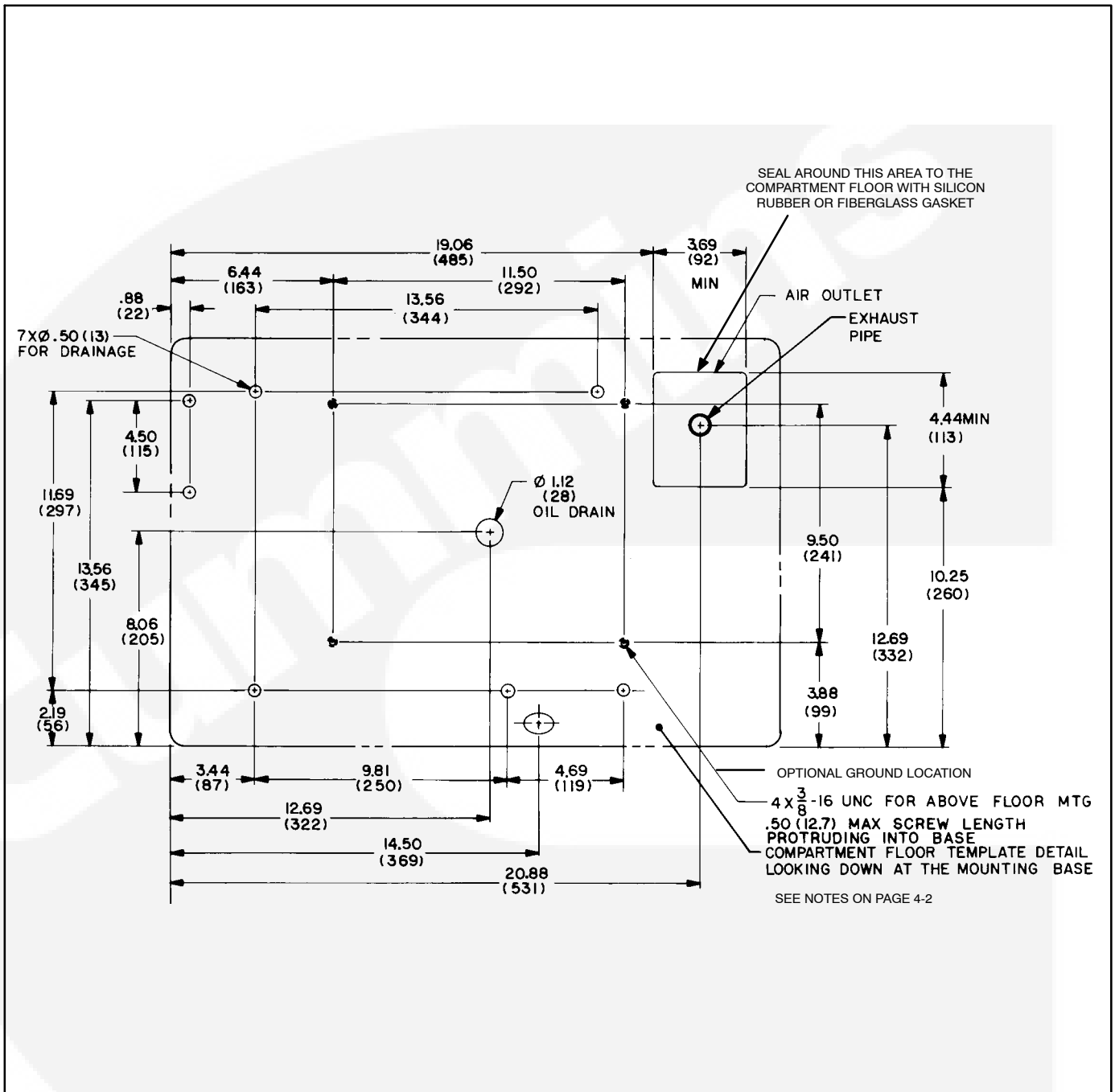

FIGURE 4-2. COMPARTMENT FLOOR PLAN

UNDER-FLOOR MOUNT

In an under-floor installation, the genset is mounted below the floor and outside the passenger compartment of the vehicle. This type of installation must comply with the Installation Codes and Safety Recommendations (see *Introduction* section). Read this section for general application information, and study the under-floor housing and exhaust kit instructions for more information on under-floor installations.

The vehicle structure must be able to support the weight of the genset in a dynamic environment (carefully follow the important design parameters in the instructions provided with the under-floor housing kit). The vehicle manufacturer and/or the installer must provide a structurally sound support frame, using tubing, angle brackets, or steel-reinforced plywood or other composition board. Plywood or particle board can be reinforced with 3-inch (76 mm) or larger washers or a full metal plate.

Line the floor above the set with 26-gauge galvanized steel or a material of comparable strength and fire resistance (see NFPA 70, NEC and California Title 25 for complete details).

Generator Set Location

Figure 4-3 shows the most common mounting areas for a genset. Protect the genset from road

splash and debris. If possible, drive the vehicle through mud and slush to test the installation.

Leave a minimum space of 1 inch (25.4 mm) between the genset and the vehicle skirt for an air inlet. Provide a minimum side, back and top clearance 1/4 inch (6.4 mm).

The air inlet opening to the genset compartment must not admit dirt, rocks, water or slush. The entrance of dust and salt into the compartment must be minimized. Baffles may be needed to protect certain areas. See the *Ventilation* section of this manual for more information.

Access Opening: Provide an access opening to the genset on the side of the vehicle. Make the access large enough for removal of the access cover. Also allow access to the oil drain and spark plug, so the genset does not have to be removed for servicing these items (see Figure 1-1 for locations).

Mounting Brackets: The vehicle must be adapted for use with the under-floor mounting bracket kit. The construction of the vehicle must support the weight of the genset (see *Specifications* section). It is the vehicle manufacturer and/or the installer's responsibility to provide carriage bolts to attach the under-floor mounting brackets.

Review the exhaust system kit installation instructions and check the components supplied in the kit. Plan clearances for removal of exhaust components when the set is removed for service.

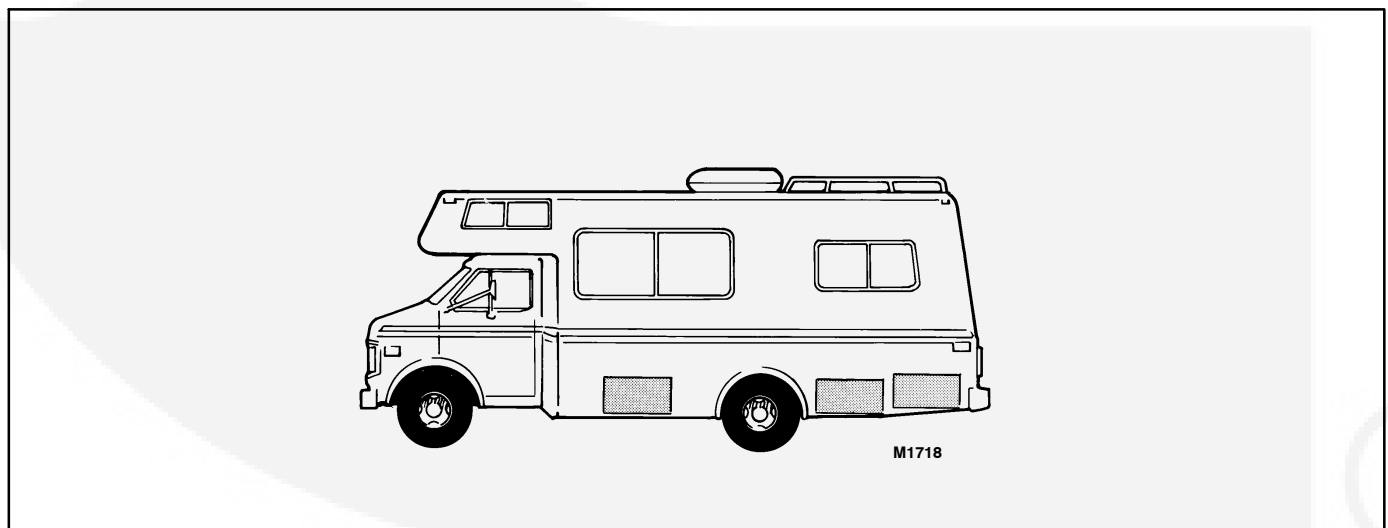

FIGURE 4-3. COMMON GENERATOR SET MOUNTING AREAS

5. Ventilation and Acoustics

GENERAL

The most important factors of ventilation for an air cooled genset are sufficient incoming air (for combustion and cooling) and adequate exhausting of heated air.

A fan draws cooling air through the inlet on the generator end and pushes it across the generator and engine cooling fins. The heated air is expelled through the air outlet on the bottom of the set. See Figure 5-1.

Make certain that nothing obstructs or restricts the air intake and air outlet. Air recirculation must be minimized. If a noise or dust deflector are added to the set, it must be located a minimum of 6 inches (150 mm) below the genset and it must be open on three sides.

⚠ WARNING *Exhaust gas presents the hazard of severe personal injury or death. Because discharged cooling air can contain deadly exhaust gas, never use discharged cooling air to heat the vehicle.*

⚠ CAUTION *Operating the genset with the cover removed can cause equipment damage. Genset cooling air does not circulate properly with the access cover removed. Do not operate the genset with the access cover removed.*

When designing the air inlet and outlet for the set compartment (see Figures 4-1 and 4-2), allow for the restriction of grilles and ductwork: some expanded metal grilles provide as little as 60 percent free air inlet area per square foot. The most efficient grille provides only 90 percent free inlet area per square foot. Obtain the free inlet area of the grille material from the material supplier. Multiply the grille area by the free area percentage to get the free inlet area.

Air ducting must provide a direct free-airflow path to the genset, with minimal bends. The duct must be smooth and non-restrictive to airflow.

Air inlet openings should be located as high as possible to allow for convection cooling of heated air from the genset compartment after unit shutdown. Otherwise, hard starting could result from vapor locking, hot combustion air, etc.

⚠ WARNING *Fuel and fuel leakage present the hazard of fire or explosion, which can cause severe personal injury or death. The ventilation system should provide a constant flow of air to expel any accumulation of fuel vapor. The genset compartment must be vapor-tight to the vehicle interior, to keep fumes from entering the vehicle.*

Locating the free air inlet opening in the vehicle skirt or side access door is recommended. If the vehicle skirt does not extend to or below the bottom of the genset, provide an extension.

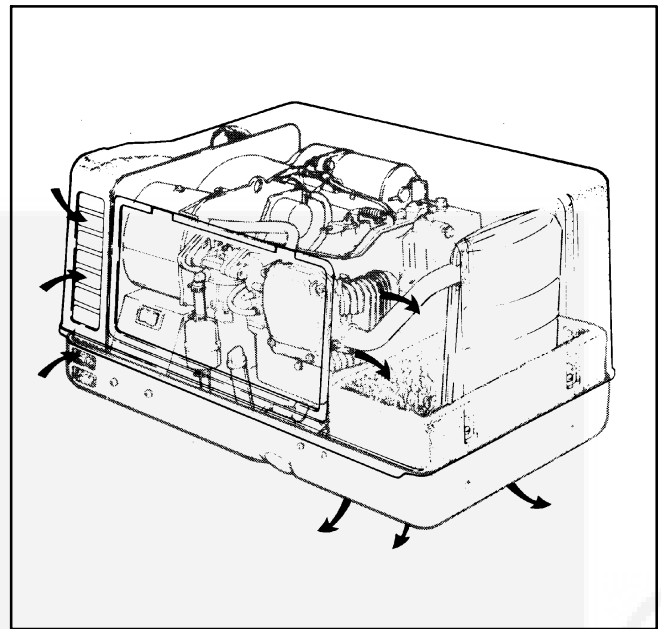

FIGURE 5-1. COOLING AIRFLOW

ACOUSTICS

The genset is designed to minimize noise levels. If additional noise reduction is required, line the top and sides of the genset compartment with a 1-inch (25.4-mm) thickness of sound absorbing material. The optional exhaust resonator can also be used to lower the noise level. Locating the air inlet away from the genset air inlet opening will reduce the noise level; however, additional compartment space will be required (see Compartment Mounting in the *Mounting* section). See the following guidelines to construct the housing.

- Make certain that all joints and corners of the compartment are vapor-tight to the interior/ cab of the vehicle. Lining the compartment is less effective if openings, cracks, doors and joints are not sealed. Seal the compartment door edge to eliminate noise leaks around the door perimeter.

- Cover the back, top and sides of the compartment (not the compartment base) with fiberglass or other self-extinguishing, sound-absorbent material. Sound insulation and adhesive should be rated at 200°F (90°C) minimum. See Figure 5-2 to design the set compartment for optimum noise reduction.
- A combination of materials can reduce noise more than a single material can. For instance, a laminate of materials of various thickness including a layer of acoustical material is more effective than a single layer of acoustical material.

⚠ WARNING *High temperatures in the compartment can present the hazard of fire, which can result in severe personal injury or death. To meet ANSI and CSA temperature rise requirements for vehicles, the layer of insulation must not reduce the minimum compartment size specified in Figure 4-1.*

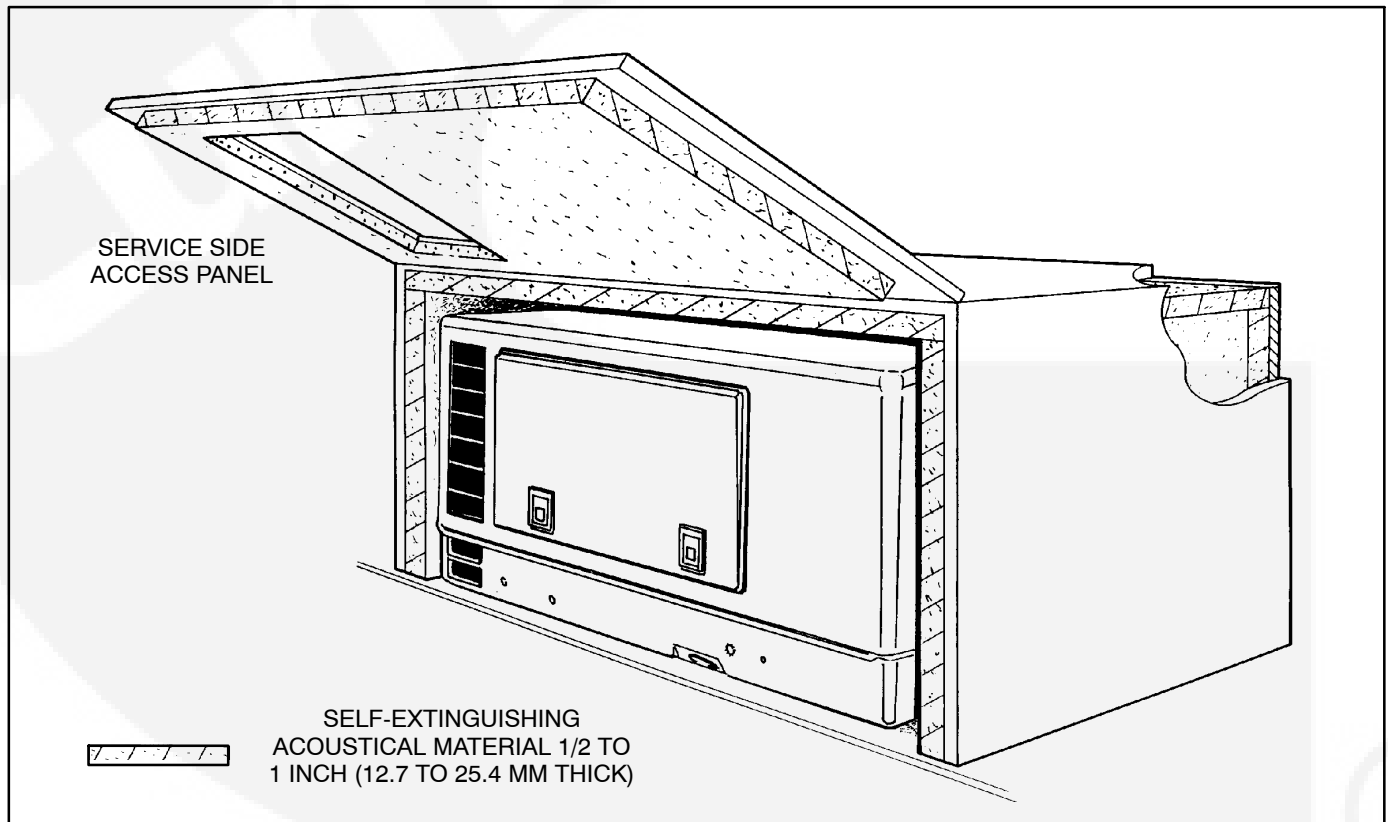

FIGURE 5-2. NOISE REDUCTION COMPARTMENT DESIGN

6. Exhaust System

GENERAL

Plan the exhaust system carefully. A proper installation is vapor-tight and quiet. The exhaust system installation must comply with all applicable standards, local codes and regulations. Study the following recommendations. See the instructions supplied with the exhaust kit for specific mounting procedures.

MUFFLER RECOMMENDATIONS

The Onan-installed spark arrester muffler is U.S. Forest Service approved and meets code requirements. Failure to provide and maintain a spark arrester can be a violation of the law.

Liability for damage or injury, and warranty expenses due to use of unapproved mufflers or installation modifications becomes the responsibility of the person installing the substitute muffler or performing the modifications. Contact an Onan distributor for approved exhaust system parts.

EXHAUST INSTALLATION GUIDELINES

Use only Onan-specified exhaust kits. These kits have been designed specifically for use with this genset. The length of pipe used in the exhaust plumbing must be tailored to each specific vehicle and is critical to the selection of the correct exhaust kit.

Exhaust kits are available for installations requiring exhaust lengths of 18 to 25 inches (457 to 635 mm) and over 25 inches (635 mm). Exhaust kits are available for installations with a vertical drop of up to 8.5 inches (216 mm), for a deep compartment floor. See Figure 6-2.

The exhaust system must be placed no closer than 3 inches (76 mm) from combustible material (wood, felt, cotton, organic fibers, etc.), or be so located, insulated or shielded that it does not raise the temperature of any combustible material more than 117°F (65°C) above the ambient air inlet temperature.

The exhaust system must extend a minimum 1 inch (25.4 mm) beyond the perimeter of the vehicle. Do not terminate the exhaust tailpipe under the vehicle. Be aware that any vent, window or opening that can be opened and that is not permanently sealed from the vehicle living space can be an avenue for carbon monoxide.

The tailpipe must not terminate so that any vent, window, or opening into the living area is within a six inch (152.4 mm) radius of the tail pipe as shown in Figure 6-1.

⚠️ WARNING *Exhaust gas presents the hazard of severe personal injury or death. Do not terminate an exhaust pipe under the vehicle. The tailpipe must not terminate so that any vent, window, or opening into the living area is within a six inch (152.4 mm) radius of the tail pipe as shown in Figure 6-1. Keep all openings closed when the genset is running.*

To reduce the chance of damaging the tailpipe and emitting exhaust gases under the vehicle, make certain that no part of the exhaust system intrudes into the departure angle or approach angle of the vehicle, unless it is protected by a skid bar or other protection device. The shaded areas in Figure 6-1 illustrate typical mounting locations.

⚠️ WARNING *Exhaust gas presents the hazard of severe personal injury or death. Do not mount any portion of the exhaust system into the approach or departure angle unless it is adequately protected. Use only Onan-specified exhaust equipment with the genset. Use a sufficient number of hangers to prevent dislocation of the system.*

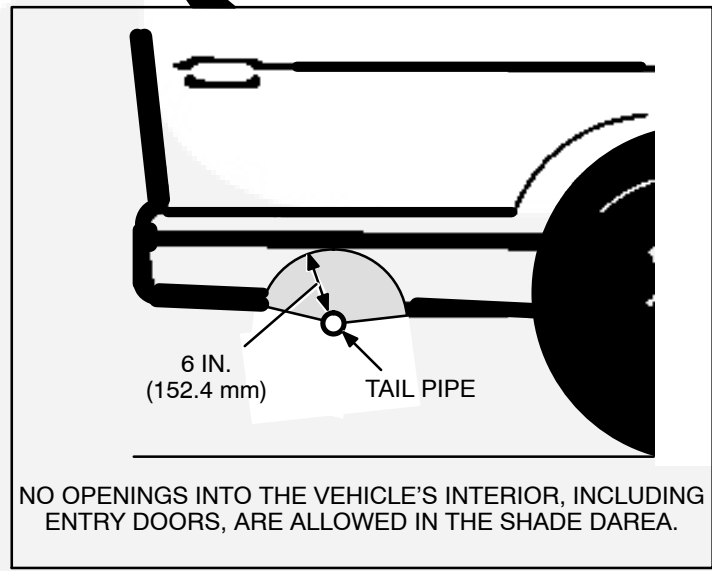
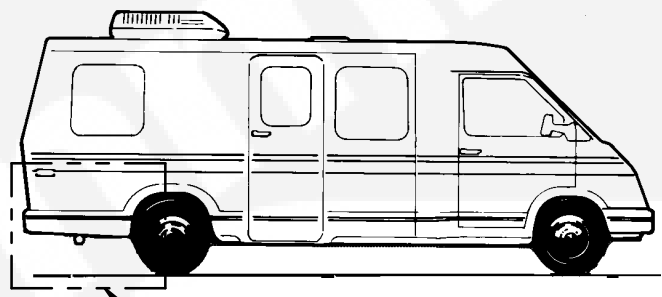
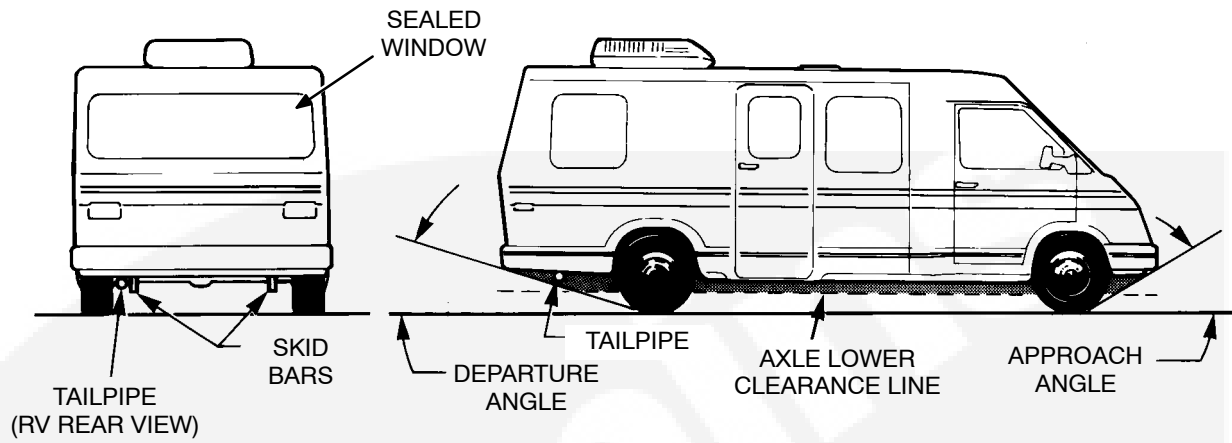

FIGURE 6-1. TAILPIPE INSTALLATION

TAILPIPE RECOMMENDATIONS

The tailpipe of the generator set will be hot during operation and can cause severe burns. To reduce the risk of contact, consideration must be taken on where the tailpipe will be located and routed.

An exhaust tailpipe is not supplied with the genset because length requirements vary between vehicle manufacturers. Refer to the following recommendations for information and safety considerations.

Use only the Onan-specified exhaust kits. Do not install a tailpipe of less than 18 inches (457 mm) in length. Do not extend the length of the 18 to 25 inch (457 to 635 mm) exhaust kit or vibration damage to the exhaust system will result.

CAUTION *Failure to follow the exhaust installation guidelines can result in damage to equipment. Use the appropriate exhaust kit and install it according to the instructions provided.*

Tailpipes crimp onto genset exhaust, the critical dimension would be I.D. minimum gauge of 18 . Some use 16 or 14 gauge material. Aluminized or stainless steel tubing is not required.

WARNING *Exhaust gas presents the hazard of severe personal injury or death. Do not use flexible exhaust tailpipe, because it can leak or break from road shock or vibration. Do not terminate the exhaust system under the vehicle. Direct exhaust gases away from any window, door, or compartment openings. Do not operate the genset without an exhaust tailpipe.*

Use a U-bolt type automotive muffler clamp marked 1-1/4 inch to connect the exhaust tailpipe to the muffler outlet. Use double rubber, U-shaped, shock-mounted hangers to support the exhaust system. If the tailpipe extends beyond 1 foot (304 mm) from the genset, attach an automotive tailpipe hanger for additional support. Also use additional automotive type tailpipe hangers every 2 to 3 feet (0.6 to 0.9 m) of tailpipe run. Support the exhaust system at or near the perimeter of the vehicle to prevent the pipe from being damaged and pushed up under the vehicle skirt. Attach hangers to steel framework, not wood or other floor materials. Refer to Figure 6-2 for typical tailpipe installations.

CAUTION *Angular mounting of muffler and tailpipe hanger brackets can result in exhaust system damage. Properly mounted hanger brackets will absorb much road shock vibration and prolong the use of exhaust system components. Mount muffler and tailpipe hanger brackets directly above the component being supported, not at an angle. Do not twist the rubber sections of any hangers.*

CAUTION *Excessive exhaust back pressure can cause engine damage. If a tailpipe deflector is used, make sure it is large enough to prevent back pressure.*

CAUTION *Water vapor can cause engine damage. Do not connect the genset exhaust to the vehicle exhaust system, because water vapor from one engine can damage the other.*



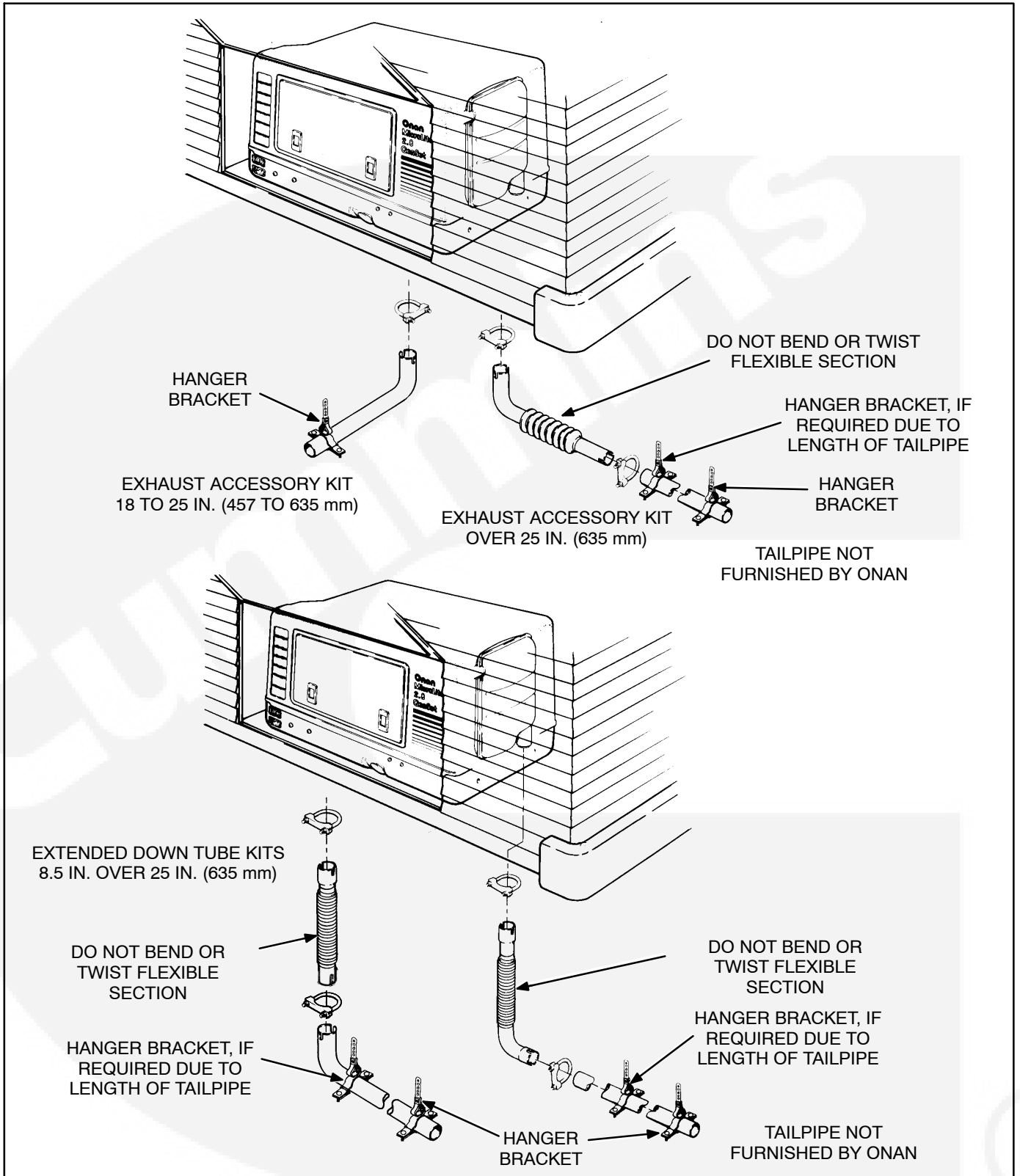

FIGURE 6-2. EXHAUST SYSTEM EXAMPLES FOR COMPARTMENT MOUNT INSTALLATIONS

7. Fuel System

GENERAL

This section describes fuel system installations for recreational vehicles and travel trailers.

⚠️ WARNING *Fuel presents the hazard of fire or explosion that can result in severe personal injury or death. Do not smoke or allow any flame, spark, pilot light, arc-producing equipment or other ignition sources around fuel or fuel components, or in the installation area. Keep a type ABC fire extinguisher nearby. The ventilation system must provide a constant flow of air to expel any accumulation of fuel vapor while the vehicle is in transit. Compartments must be vapor-tight to the vehicle interior to prevent any fumes from entering these areas.*

⚠️ WARNING *Gasoline and LPG fuel may be accidentally ignited by electrical sparks, presenting the hazard of fire or explosion, which can result in severe personal injury or death. For this reason, when installing the genset:*

- *Do not tie electrical wiring to fuel lines.*
- *Do not run electrical lines and fuel lines through the same compartment openings.*
- *Keep electrical and fuel lines as far apart as possible.*
- *Place a physical barrier between fuel lines and electrical lines wherever possible.*
- *If electrical and fuel lines must pass through the same compartment opening, make certain that they are physically separated by running them through individual*

channels, or by passing each line through a separate piece of tubing.

GASOLINE FUEL SYSTEM

Fuel System Provisions

The genset fuel pump has an integral fuel shutoff valve as a safety feature. If the vehicle fuel tank becomes pressurized (3 psi maximum), the positive fuel shutoff prevents the genset from being flooded when the genset is not running. The vehicle fuel tank gas cap should relieve pressure at 1-1/2 psi.

Travel trailer installations can use an optional remote fuel tank to supply fuel to the genset. See Remote Fuel Tank section.

Onan recommends installing an in-line manual fuel shutoff valve, to close the fuel line when the set is removed for service.

Recommended Fuel

See the Operator's Manual for fuel recommendations.

⚠️ WARNING *Fuel presents the hazard of fire or explosion that can cause severe personal injury or death. Never fill the fuel tank when the engine is hot or is running. Do not permit any flame, spark, pilot light, cigarette or other ignition source near the fuel system.*

Fuel Consumption

Genset fuel consumption varies proportionately to the amount of electrical load. Refer to the *Specifications* section for approximate fuel consumption at no load, half load, and full load.



Fuel Line Installation

Mounted Fuel Tank: Vehicle fuel systems operate at a specified fuel pressure. For this reason, do not change or remove the fuel fill tube, fill limiter vent, vapor canister, vapor lines, filler cap or any part of the fuel system without the approval of the vehicle manufacturer. Check the filler cap to make sure that the pressure vacuum relief valve functions properly at 1-1/2 psi: replace it if it is defective.

Do not tie the genset fuel line into the vehicle fuel supply line. Unauthorized fuel system modifications can cause dangerous operating conditions.

- Tying a genset fuel line into a **vacuum** supply line (vehicle fuel pump at the engine) can cause the genset to starve for fuel at highway speeds or during acceleration.
- Tying a genset fuel line into a **pressure** supply line (vehicle fuel pump in the fuel tank) can cause poor genset operation and create a hazard of fire or explosion caused by fuel leakage.

Some vehicle manufacturers permit tying into the fuel **return line** on high pressure fuel systems. Contact the vehicle manufacturer for details and approval. The fuel return line pressure at the point of connection must not exceed 1-1/2 psi, or carburetor flooding could result.

If a separate connection is not supplied for the genset, add a second fuel pickup in the tank. This pickup should not extend below the bottom 1/4 of the tank, so the vehicle will run after the genset runs out of fuel.

⚠ WARNING *Gasoline presents the hazard of explosion or fire, which can result in severe personal injury or death. Do not connect the genset fuel line to the pressurized part of the vehicle fuel system. Flooding of the genset compartment can occur, resulting in a fire hazard.*

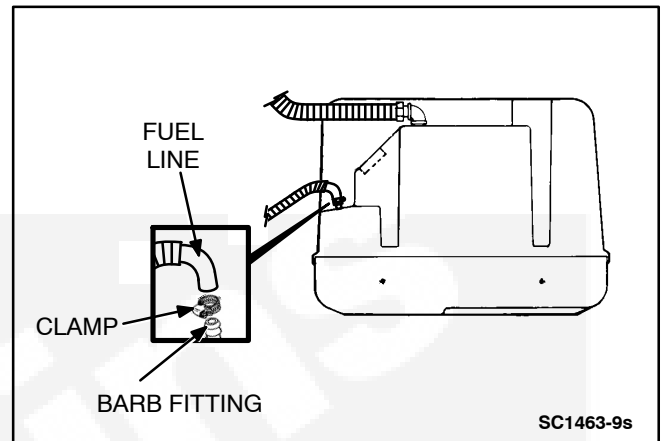

FIGURE 7-1. GASOLINE FUEL LINE CONNECTION

⚠ CAUTION *Connecting the genset fuel line with a tee to the main fuel line can result in the genset starving for fuel when the vehicle is operated at highway speeds. The genset fuel pump does not have the power to overcome the draw of the vehicle engine fuel pump. For this reason, use a separate fuel line to the genset, or use a separate fuel tank.*

Connect a 1/4-inch I.D. fuel hose (type SAE 30-R7) to the barb fitting on the genset (Figure 7-1). Secure fuel hose to barb fitting with a stainless steel clamp (worm-gear type). Do not over tighten clamp or the hose could be damaged. The fuel hose must be long enough to allow genset movement, and prevent binding, stretching or breaking.

Onan recommends copper or hot dip coated seamless steel tubing (conforming to ASTM A-254) and double flared connections for long runs between the fuel tank and the flexible connector to the genset.

Run the fuel line at the same height as the top of the fuel tank (or above the tank) to a point as close to the genset as possible. This reduces the danger of fuel siphoning out of the tank if the line should break. The maximum fuel pump lift of the genset is 3 feet (0.91m).

Keep fuel lines away from hot engine or exhaust areas, to reduce the chance of vapor lock.

Fuel lines should be accessible and protected from damage. Use metal straps without sharp edges to secure fuel lines. Do not run fuel lines where they may contact sharp or rough surfaces, or where they may be kinked, pinched, chaffed, or struck. If fuel lines enter vehicle interior, seal openings around the line to prevent entry of exhaust fumes.

Remote Fuel Tank: A remote fuel tank can be used in travel trailer and other special installations. Fill the tank with the recommended fuel and connect the genset fuel line to the tank using quick disconnect fittings. Route the fuel line away from any hot exhaust system components, moving parts, sharp or abrasive surfaces, and road hazards. Do not locate the fuel supply more than 3 feet (914 mm) below the genset to prevent exceeding the fuel pump lift capacity.

Observe all applicable codes and regulations for storage, transporting and handling of remote fuel tanks. The fuel tank must be installed in its own compartment. The compartment must be vapor tight from the interior of the vehicle and the compartment must be fire resistant. See Figure 7-2 for minimum compartment dimensions for the optional Onan remote fuel tank.

The compartment must be vented to prevent the accumulation of fuel fumes. Provide a vented bottom in the compartment and provide a minimum of 6 sq. in. (387 sq. mm) of opening in the top of the access door.

The fuel system must be designed so that fuel leakage could not contact electrical or exhaust system components. Maintain at least 6 inches (152 mm) clearance between the fuel system and any unshielded exhaust system component.

The fuel tank must be securely fastened inside the compartment. Mounting straps can be used to secure the tank.

⚠ WARNING *Fuel presents the hazard of fire or explosion that can cause severe personal injury or death. Do not store or transport a remote fuel tank inside a vehicle. Observe all applicable codes and regulations for storage, transporting, and handling of remote fuel tanks.*

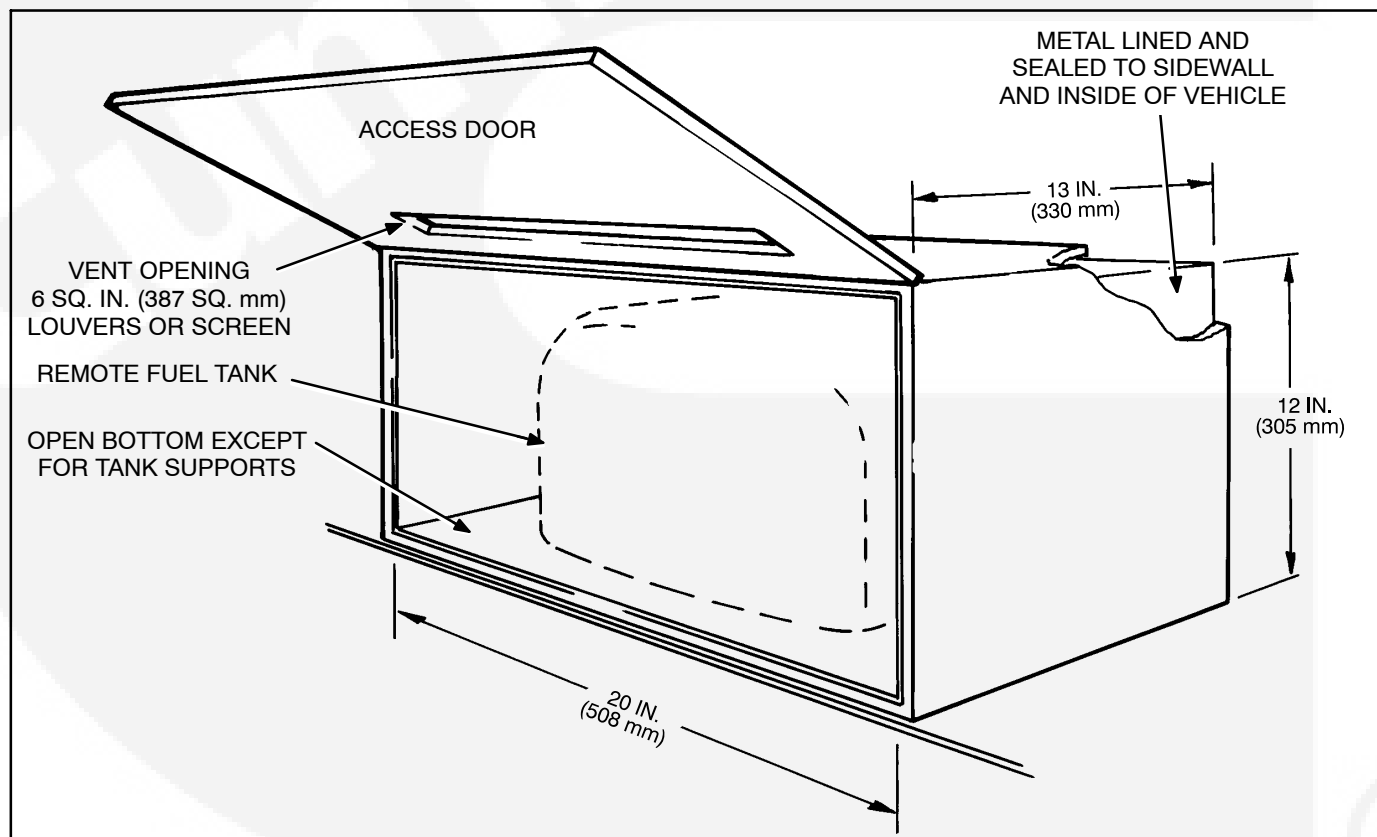

FIGURE 7-2. TYPICAL REMOTE FUEL TANK COMPARTMENT

EVAPORATIVE SYSTEM INSTALLATION

These instructions cover installation of the generator set fuel evaporative system provided for compliance with the California code of regulations for small off-road equipment effective January 1, 2008 and Federal Small SI regulation effective January 1, 2011.

For safety and compliance, the installation must be in accordance with these instructions.

The instructions apply to the following generator set model:

2.8LVFA6050

Completing the installation of the genset evaporative fuel system is required for all towable or similar generator set applications where on-board gasoline fuel storage is self-contained in the trailer equipment.

It is the responsibility of the towable equipment manufacturer OEM to complete the installation of the evaporative fuel system exactly as specified in the CARB EO & EPA certification for the Cummins Onan product being installed. These requirements are detailed in the procedure below. Any deviations from this installation procedure will forfeit the emission certification on the fuel system and transfer engine evaporative emission certification responsibility to the trailer equipment manufacturer/OEM per CFR 40 Part 1060.

If purchasing a complete or partial fuel system kit or components from a third party fuel system manufacturer, the requirements of this Cummins installation manual shall be met and the system must be verified by the OEM & fuel system supplier as meeting these requirements before completing the installation.

Any construction deviations from these assembly requirements would invalidate the evaporative certification per CFR 40 Part 1060 & Article 1, Chapter 9, Division 3 Title 13 sections 2400 through 2773 and the towable equipment OEM would then be responsible for recertification of the fuel system with California Air Resources Board and US EPA.

Any questions regarding these installation instructions or evaporative emission certification should

be directed to Cummins Power Generation for clarification.

System Components

The evaporative system consists of the fuel tank, carbon canister, generator set and connecting hoses. Gasoline vapors in the fuel tank accumulate in the carbon canister from which they are drawn into the engine combustion chamber and burned while the generator set is operating.

Fuel Tank

Note: The following specifications apply only to evaporative emissions performance. The installer is also responsible for the selection and installation of the fuel tank to meet other safety and performance requirements that may be applicable.

For compliance with evaporative emissions regulations, the fuel tank shall:

1. Be metal.
2. Have a 6 to 35 gallon capacity.
3. Have a permanently tethered cap.
4. Have cap that provides a vapor seal and that audibly signals that the vapor seal has been established.
5. Have a roll-over vent valve with connection for 5/16 inch ID hose. This hose connects to the carbon canister.
6. Have a fill-neck and an anti-spit-back valve if it is a non top-fill tank.
7. Be constructed to meet the requirements of Section 393.67 (joints, fittings and threads) of the Federal Motor Carrier Safety Administration Regulations.
8. Have connections that meet the requirements of the following SAE standards, when applicable: J1231 (Formed Tube Ends for Hose Connections and Hose Fittings), J1508 (Hose Clamp Specifications), J2260 (Nonmetallic Fuel System Tubing with One or More Layers), J2044 (Quick Connector Specification for Liquid Fuel and Vapor/Emissions Systems), and J2599 (Fuel Filler Pipe Assembly Design Practice to Meet Low Evaporative Emission Requirements).

Carbon Canister

Use a Delphi carbon canister shown below. No other carbon canisters are acceptable.

Part Number	Description
17208276	2.1L, 130g working capacity, 24.5 gallon max
17208238	3.1L, 196.5g working capacity
17208262	3.3L, 233.8g working capacity

Mount the canister in an acceptable orientation (Figure 7-3) in accordance with its instructions.

Connect the 5/16 inch hose barb (identified by the fuel pump icon) to the hose from the fuel tank and the adjacent 3/8 inch hose barb to the hose from the generator set. See Figure 7-4.

Note: Use 5/16 inch hose for vapor lines. Use an SAE J2044 quick connect fuel fitting on the canister hose barb or use a soap-free lubricant such as WD40 to slip the hoses on the canister hose barbs. Secure the hoses with Oetiker® ear-type clamps or equivalent.

To prevent dirt from entering the canister vent when it is mounted in a “dirty” location, connect the 5/8 inch hose barb to a hose terminated outside the living space of the vehicle at a location that is not exposed to road splash or dust. Alternatively, secure Onan Part Number 0148-1343 vent filter to the hose barb.

CAUTION *Blockage of the canister vent or vent hose could lead to collapse of system components due to vacuum.*

WARNING *Do not vent the canister into the vehicle or other confined space where the vapors could accumulate to a flammable level.*

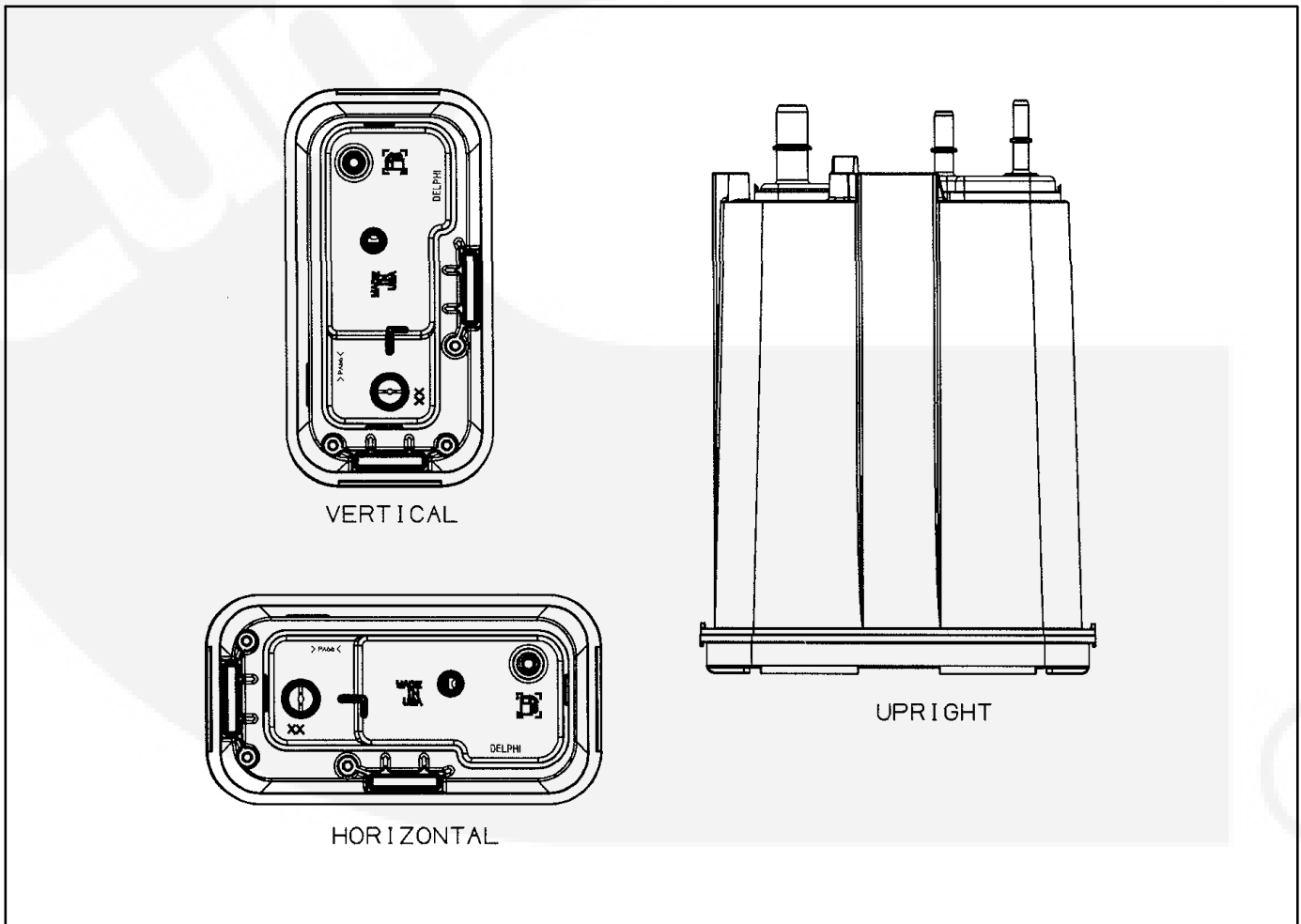

FIGURE 7-3. ACCEPTABLE CANISTER MOUNTING ORIENTATIONS

Generator Set

Connect the 5/16 inch generator set hose barb to the vapor purge hose from the carbon canister. Connect the 1/4 inch hose barb to the fuel supply hose from the fuel tank. See Figure 7-4.

Gasoline Hoses

The fuel hoses used inside the generator set are low permeation fuel hoses which meet Federal and California standards for gasoline evaporative emissions.

The vapor and liquid hoses connecting the fuel tank to the generator set, the fuel tank to the carbon canister and the carbon canister to the generator set must also be low permeation fuel hoses. Low permeation fuel hose is required to meet these requirements for gasoline generator sets sold in or used for commerce in the State of California. The following hose materials are acceptable:

- Avon Automotive “Greenbar” (EO# G-05-018) SAE J30R7
- Avon Automotive “Greenbar 1200” (EO# C-U-05-009) SAE J30R12
- Gates 4219D (EO# C-U-06-002) SAE J30R9

- Gates Barricade (EO# Q-09-019)
- Kubota (EO# C-U-05-003) SAE J30R7
- Mark IV Automotive “Gen 2” (EO# C-U-05-002) SAE J30R7
- Mark IV Automotive “Fluoroperm” (EO# C-U-07-017) SAE J30R9
- Mark IV Automotive “Dayperm” (EO# C-U-06-030) SAE J30R7
- Mark IV Automotive “Dayperm” (EO# G-05-016)
- Mold-Ex Division of SETi, Inc. “SETIFLEX II” (EO# G-05-17A) SAE J30R7
- Parker Hannifin Corp “Super Flex FL-7 series 389XX” (EO# Q-08-013)
- Veyance Technologies Inc. “Goodyear Flexshield” (EO# Q-09-022)

Lubricants used when connecting fuel hoses can leave residues that can clog fuel jets. Only use “soap-free” lubricants such as WD40.

⚠ CAUTION *When connecting fuel hoses, only use soap-free lubricants such as WD40, which runs through with the fuel without leaving residues that can clog fuel jets.*



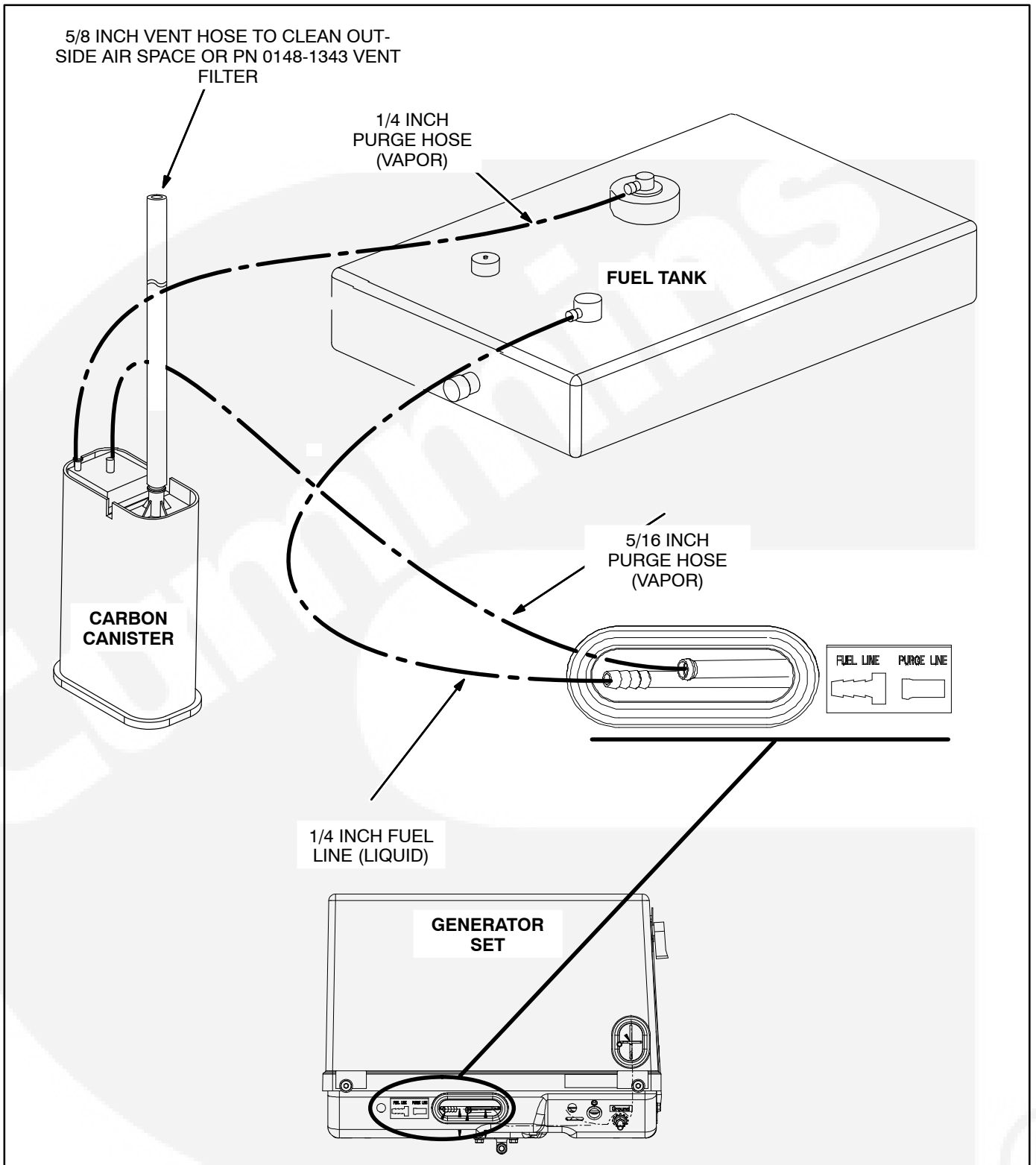

FIGURE 7-4. EVAPORATIVE SYSTEM COMPONENTS

LPG FUEL SYSTEM

Fuel System Provisions

LPG models are designed for a low-pressure vapor-withdrawal type of LPG supply system. See Figure 7-5. *LPG supply pressure at the inlet to the demand regulator must be 9 to 13 inches (229 to 330 mm) water column (WC) when the genset is running under full load.*

⚠️ WARNING *LPG fuel presents the hazard of explosion or fire that can result in severe personal injury or death. Do not connect the genset fuel line directly to the LPG fuel cylinder or fuel leakage could result from excessive fuel inlet pressure. A regulator must be used between the genset and the fuel cylinder that reduces supply pressure to 9 to 13 inches (229 to 330 mm) water column.*

LPG set operation is highly sensitive to variations in altitude, temperature, and fuel BTU content. For this reason, the fuel system may need to be adjusted after installation. Refer to the Service Manual if adjustments are required.

Recommended Fuel

See the Operator's Manual for fuel recommendations.

Fuel Consumption

Genset fuel consumption varies proportionately to amount of electrical load. Refer to the *Specifications* section for approximate fuel consumption at no load, half load, and full load.

Propane Fuel Lines and Supply Tank

⚠️ WARNING *LPG fuel presents the hazard of fire or explosion that can cause severe personal injury or death. Do not permit any flame, spark, arcing switch or equipment, pilot light, cigarette, or other ignition source near the fuel system. Keep an ABC type fire extinguisher nearby.*

Review each of the codes that apply to LPG genset installation. Paragraph 2-11 (LP-Gas Engine Fuel

installations) of NFPA Pamphlet 501C and paragraph 3-6.2.5 of NFPA 58 (piping hose and fittings). These sections deal with fuel tanks and lines, but does not cover all applicable codes and regulations. Obtain this information by writing to the address listed in the beginning of this manual.

For a long fuel line run, use seamless steel tubing with flared ends. Make flexible hose connections at the fuel tank and at the genset. Use 3/8-inch I.D. fuel line for runs up to 5 feet (1.5 m) long provided that, in addition, no more than 20 feet (6.1 m) of pipe or tubing with an I.D. of at least 5/8-inch is used. Use 1/2-inch I.D. fuel lines for runs up to 15 feet (4.6 m).

Mount a manual shutoff valve on the fuel supply tank. When installing the fuel lines, keep these factors in mind:

- Install LPG fuel lines to be accessible, but protected from damage.
- Use metal straps without sharp edges to secure fuel lines.
- Keep fuel lines away from hot engine or exhaust.
- Do not run fuel lines next to electrical wiring.

Do not connect the genset fuel supply line to any appliance fuel supply line. The genset can draw fuel away from other appliances and cause a flame out. To prevent the possibility of flameout, the fuel supply system must be designed to deliver sufficient fuel for normal operation of the genset and other appliances at the expected temperature conditions. It may be necessary to use a separate fuel tank for the genset if sufficient fuel cannot be supplied with a single tank system.

⚠️ WARNING *LPG fuel presents the hazard of explosion or fire which can result in severe personal injury or death. If flameout occurs with an unvented appliance, LP gas can accumulate inside the vehicle and create a safety hazard. Do not connect the genset fuel supply line to an LP gas supply line that is supplying another appliance.*

Testing Fuel System for Leaks

Before operating the set, test the LPG fuel system for leaks. Testing must conform to procedures listed in NFPA-58, or to the UL recommended test procedure, as follows:

After assembly and before initial operation, all fuel system connections, hose, valves, regulators, and fittings must be tested and proven free of leaks using a soap-and-water (or equivalent) solution while

the system is under gas or air pressure of at least 90 psi (620 kPa).

⚠ WARNING *LP gas (Propane) presents the hazard of fire or explosion that can cause severe personal injury or death. Do not permit any flame, spark, pilot light, cigarette, or other ignition source near the fuel system. Keep an ABC type fire extinguisher nearby.*

Other approved methods of detecting leaks may be used if appropriate. This test must not be made with a flame.

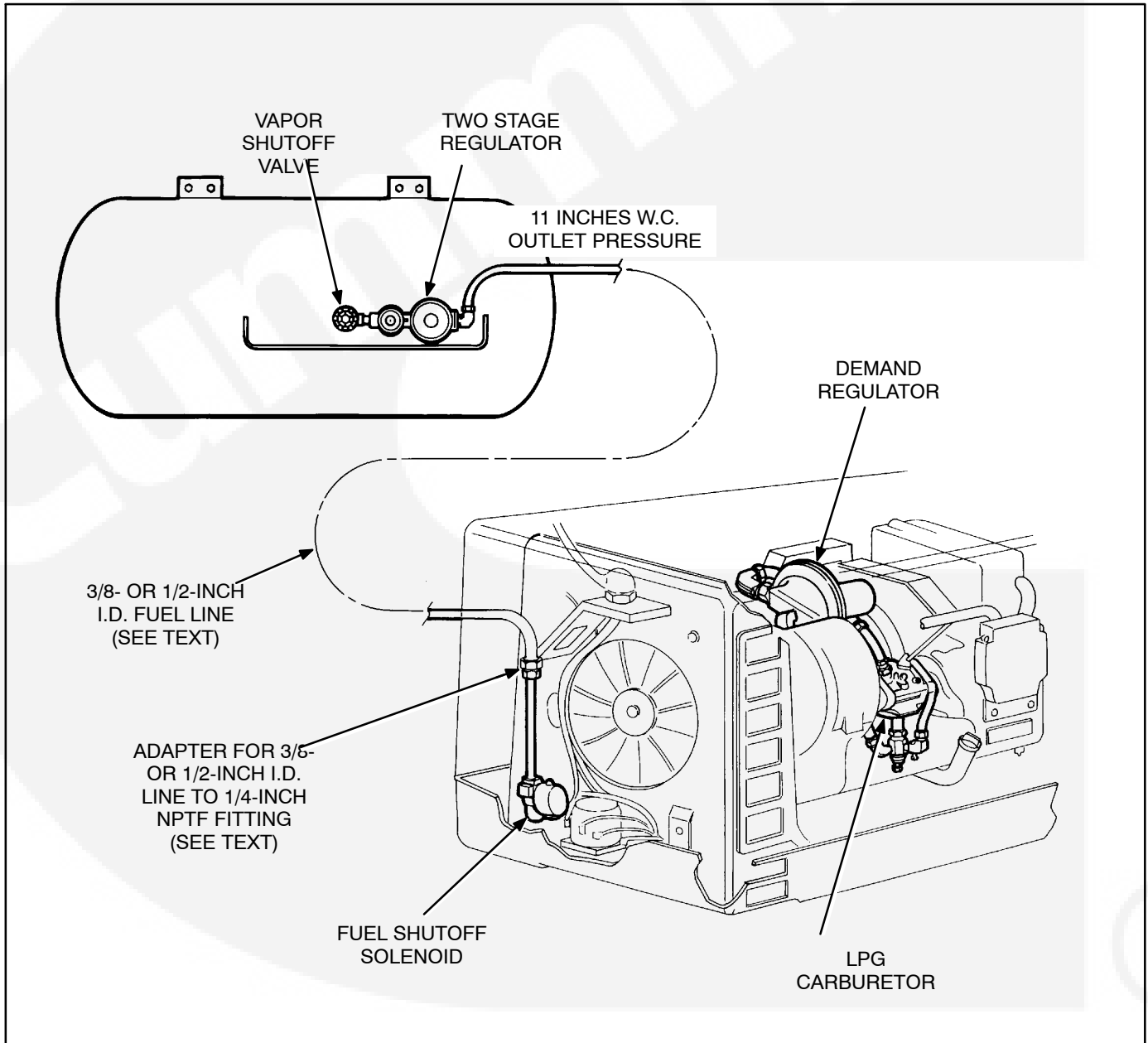

FIGURE 7-5. TYPICAL LPG VAPOR WITHDRAWAL FUEL SYSTEM



THIS PAGE IS INTENTIONALLY LEFT BLANK



8. Electrical Connections

General

⚠️ WARNING **HAZARDOUS VOLTAGE!** *Touching uninsulated live parts inside the generator set and connected equipment can result in severe personal injury or death. For your protection, stand on a dry wooden platform or rubber insulating mat, make sure your clothing, and shoes are dry, remove jewelry from your hands and use tools with insulated handles. Secure protective covers when completing installation.*

⚠️ WARNING **IMPROPER WIRING** *can cause fire or electric shock resulting in severe personal injury or death.*

This section covers installing the genset electrical system for:

- Connecting the load
- Connecting a remote control (if used)
- Connecting the genset starting battery

Connect the battery last, to avoid accidentally starting or short-circuiting the set during installation. Connect the positive (+) battery cable first and the negative (-) battery cable last to reduce the risk of arcing.

⚠️ WARNING *Accidentally starting the genset during installation can cause severe personal injury or death. Do not connect the starting battery until instructed to do so in the Initial Starts and Checks section.*

The wiring must meet all applicable electrical codes. For this reason, a qualified electrician should install and inspect the wiring.

Mount switches and controls securely, to prevent damage from vibration and road shocks. All switches must be vibration-proof to prevent accidental opening or closing while the vehicle is in motion.

AC Wiring

Wire Types

The leads attached to the genset output must have a current rating of not less than 115 percent of the

nameplate current rating of the genset. The Onan-supplied AC feeder conductor insulation is rated at 125°C. Wires connected to the Onan feeder conductors must either meet this insulation rating, or be a larger size (see National Electrical Code, NFPA 70).

Use stranded wire for all load connections. Load wiring must be appropriately sized and insulated for the specified current rating. Grounding must comply with all codes.

Conduit

Install the generator load conductors in a flexible metallic conduit. Cut the conduit to length, leaving extra wire for the junction box connections. Connecting wires must be correctly sized and insulated for the current rating. Round off or cover the ends of the conduit, to prevent its sharp edges from cutting the insulation.

Use waterproof conduit in applications where the conduit will be exposed to the elements. Run the conduit so that it does not interfere with the movement of the genset.

To reposition the 90° conduit fitting, loosen the locking nut (toothed ring), turn fitting counterclockwise to desired location, and tighten locking nut.

Seal all openings made for conduit, so exhaust or fuel vapor cannot enter the living quarters. Flexible metal conduit must be sealed internally at the end where it terminates inside the junction box or panel board (flexible conduit is not vapor-tight along its length).

⚠️ WARNING *Exhaust gas and fuel fumes present the hazard of severe personal injury or death. To prevent exhaust gas and fuel fumes from entering the vehicle interior, seal all openings made for conduit, wiring, etc. Also seal the wiring within the conduit itself. Use only a silicone/rubber based sealant.*

Wiring Disconnect Method

There must be no chance that an outside power source be connected to the generator set. Feeder conductors from the set compartment must terminate in a 120-volt double-pole, double-throw, positive-off switching device mounted ahead of the vehicle distribution panel; or they must connect to a genset receptacle box. Figures 8-1 and 8-2 show examples of the wire connection.

Line Circuit Breaker

The genset has a line circuit breaker mounted on the side of the control panel. The breaker provides short circuit and overload protection for the generator.

Load Connections

The generator output voltage and maximum current rating are specified on the genset nameplate.

Load wiring must be appropriately sized and insulated for the specified current rating. Grounding procedures must comply with codes.

A lead to be connected to an output feeder conductor shall not be more than two AWG sizes smaller than the output lead conductor and the insulation shall be:

- Rubber (with braid), neoprene, or thermoplastic, with a wall thickness of at least 0.030 inch (0.76 mm).
- Other material having the same or better electrical and mechanical properties.

⚠ WARNING *Electrical shock can cause severe personal injury or death. Use only approved power supply assemblies. Never remove the grounding pin from assemblies. Incorrect ground or no ground can cause the vehicle to become electrically “hot”. Equip the vehicle with adequate Ground-Fault Circuit Protection devices to meet the National Electrical Code (NFPA 70, 551-9 C) and for personal safety.*

⚠ WARNING *Gasoline fuel presents the hazard of fire or explosion, which can result in severe personal injury or death. Do not tie electrical wiring to fuel lines.*

⚠ WARNING *Gasoline and LPG fuel may be accidentally ignited by electrical sparks, presenting the hazard of fire or explosion, which can result in severe personal injury or death. For this reason, when installing the genset:*

- *Do not tie electrical wiring to fuel lines.*
- *Do not run electrical lines and fuel lines through the same compartment openings.*
- *Keep electrical and fuel lines as far apart as possible.*
- *Place a physical barrier between fuel lines and electrical lines wherever possible.*
- *If electrical and fuel lines must pass through the same compartment opening, make certain that they are physically separated by running them through individual channels, or by passing each line through a separate piece of tubing.*



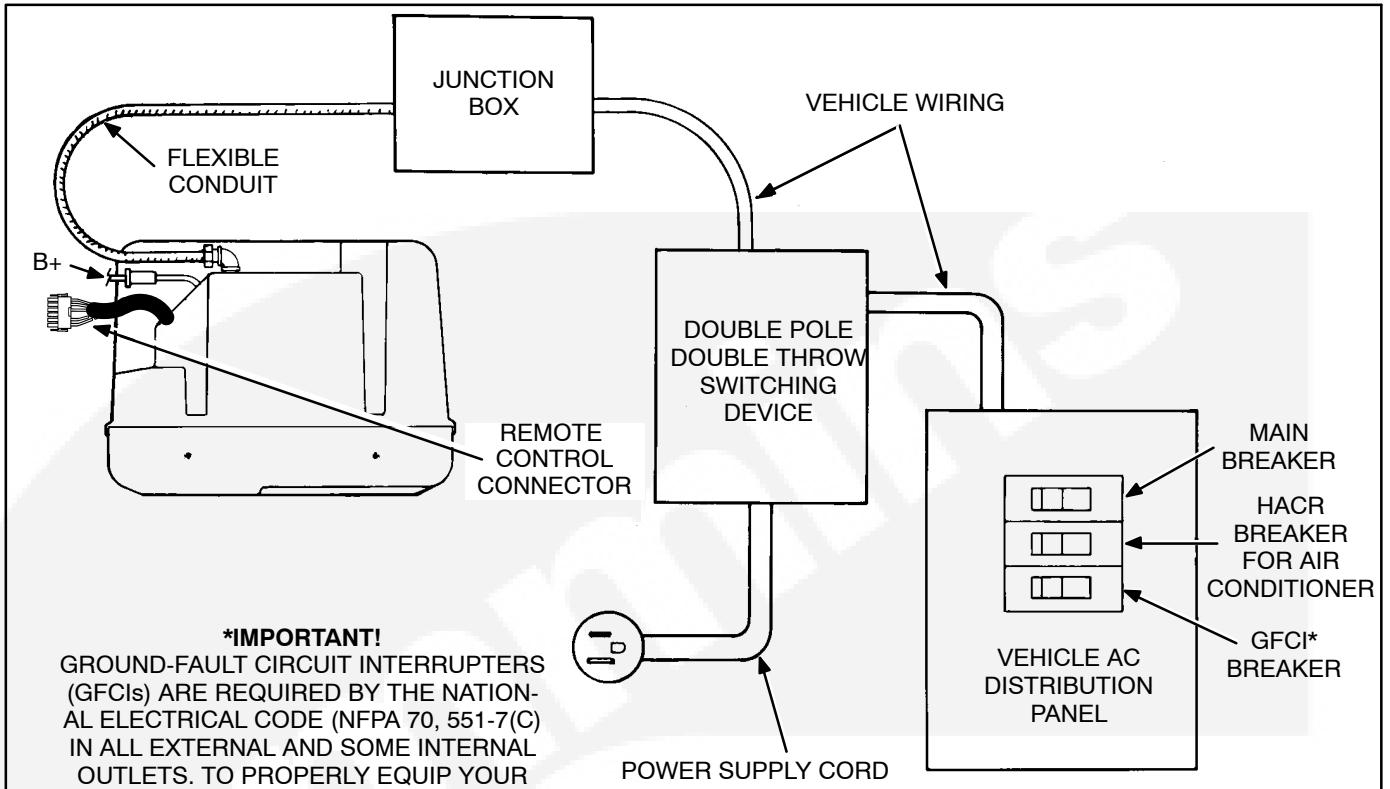

***IMPORTANT!**
 GROUND-FAULT CIRCUIT INTERRUPTERS (GFCIs) ARE REQUIRED BY THE NATIONAL ELECTRICAL CODE (NFPA 70, 551-7(C)) IN ALL EXTERNAL AND SOME INTERNAL OUTLETS. TO PROPERLY EQUIP YOUR RECREATIONAL VEHICLE WITH THESE PROTECTION DEVICES, CONTACT YOUR RV MANUFACTURER OR DEALER FOR RECOMMENDATIONS.

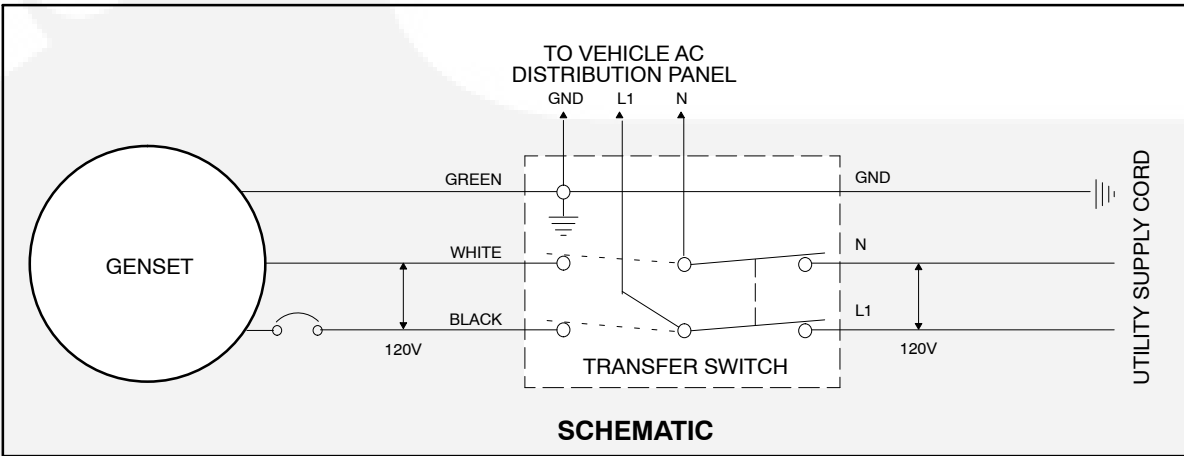

FIGURE 8-1. SWITCHING DEVICE WIRING FOR UTILITY POWER

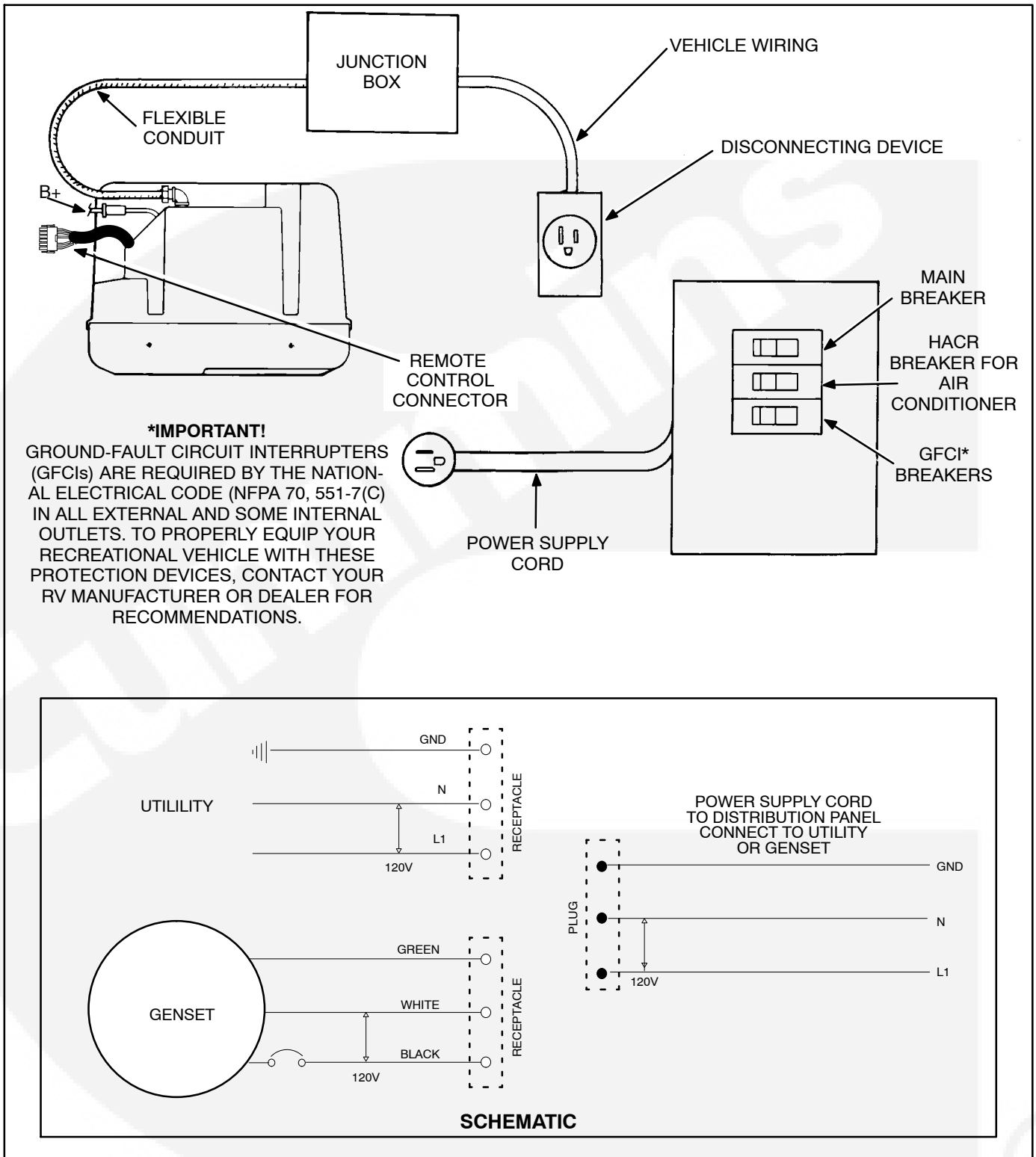

FIGURE 8-2. UTILITY POWER CORD FOR SWITCHING

DC Wiring

These sets have a 12 VDC, negative-ground engine control and cranking system.

Remote Control (Option)

Onan offers optional remote control kits that can be connected to the genset. There are three models available:

- Remote panel with start/stop switch and indicator lamp only (see Figure 8-3).
- Remote panel with start/stop switch, indicator lamp, and hour (elapsed time) meter (see Figure 8-4).
- Remote panel with start/stop switch, indicator lamp, and battery DC voltmeter (see Figure 8-5).

The location of the remote control panel can vary by application. Refer to the instructions supplied with the remote control kit for more installation information and important safety precautions.

Be sure to seal all openings made for wiring so exhaust or fuel vapors cannot enter the living quarters. If flexible metal conduit is used, it must be sealed internally at the end where it terminates. Flexible metal conduit is not vapor-tight along its length due to its construction.

⚠ WARNING *Inhalation of exhaust gas or ignition of fuel vapor can cause severe personal injury or death. Be sure to vapor-seal flexible metal conduit and all openings made during installation of the genset with a silicone/rubber based sealant.*

A remote control connector is located on a pigtail lead on the outside of the genset (see Figure 8-6). Contact an Onan dealer for the proper remote connector plug and wiring harness assembly.

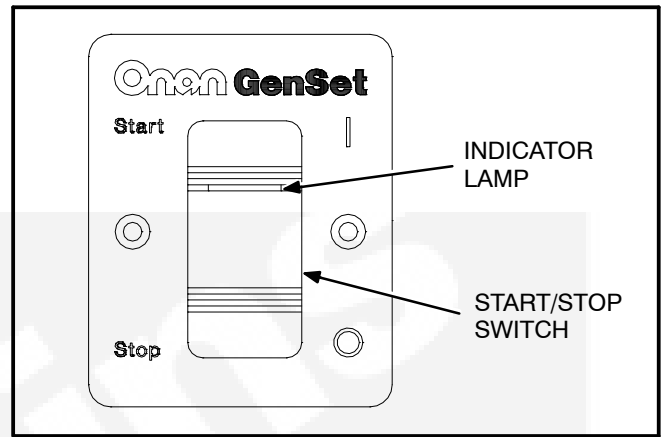

FIGURE 8-3. REMOTE PANEL WITH START/STOP SWITCH ONLY

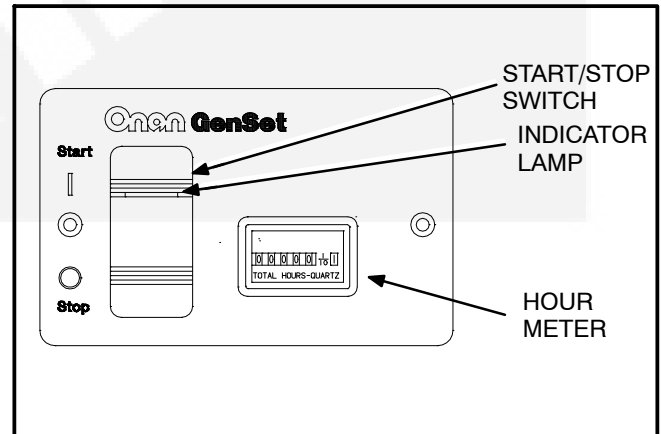

FIGURE 8-4. REMOTE PANEL WITH START/STOP SWITCH AND HOUR METER

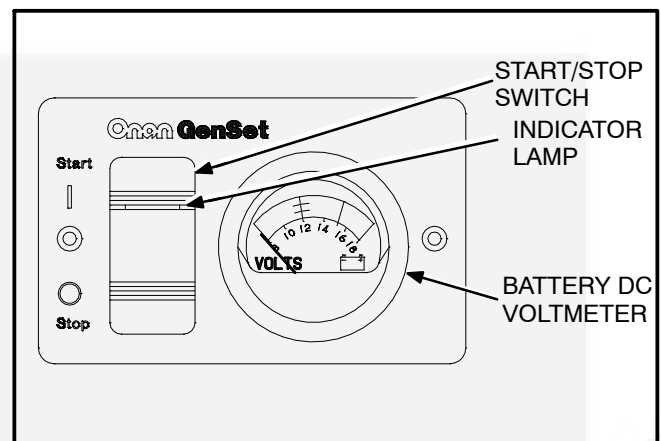

FIGURE 8-5. REMOTE PANEL WITH START/STOP SWITCH AND DC VOLTMETER

For non-Onan remote control panels, refer to Figure 8-7 for a typical remote control wiring diagram. The connector which mates with the genset connector can be ordered from Onan. Refer to the Onan Accessory Catalog.

BATTERIES

To prevent accidental starting of the genset during installation, do not connect the battery cables at the battery until so instructed in the Initial Start and Checks section.

⚠️ WARNING *Accidental starting of the genset can cause severe personal injury or death. Do not connect the starting battery until so instructed in the Initial Start and Checks section.*

Onan does not recommend that the vehicle starting battery be used to operate the genset. Doing this can discharge the battery under some operating conditions.

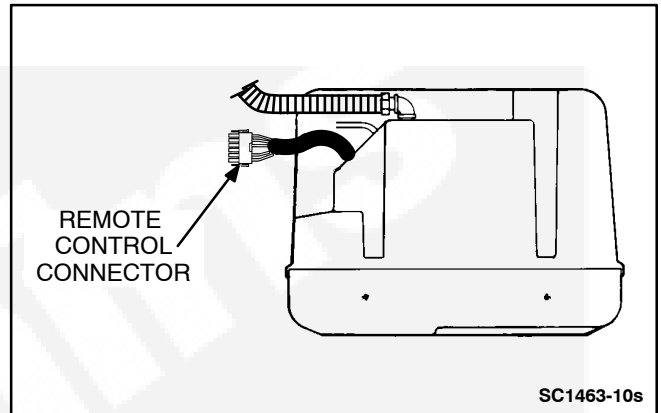

FIGURE 8-6. REMOTE CONTROL CONNECTOR

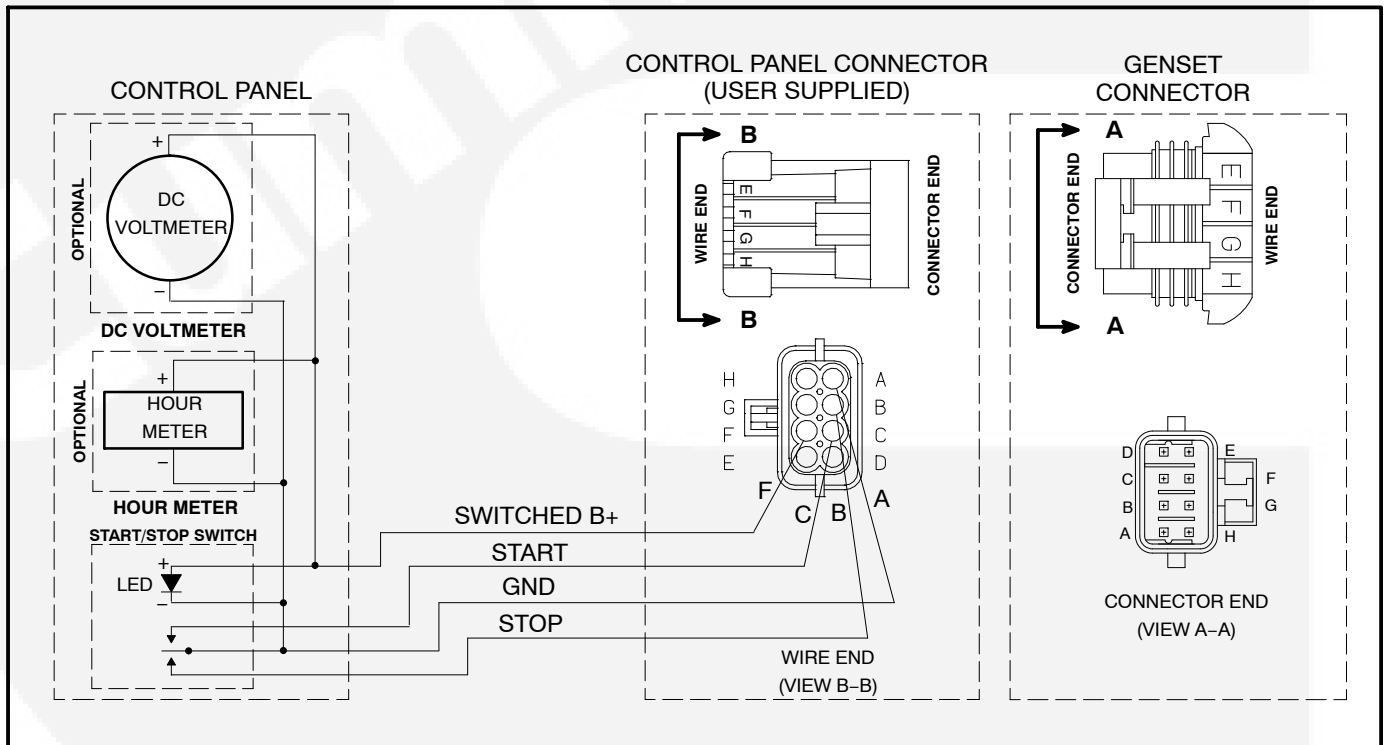

FIGURE 8-7. TYPICAL REMOTE CONTROL WIRING DIAGRAM

Battery Capacity

The genset has a 12 VDC, negative-ground control and starting system. See Table 8-1 for minimum battery capacity requirements.

TABLE 8-1. COLD CRANKING AMPS FOR MINIMUM 12-VOLT BATTERY

ABOVE 32° F (0° C)	BELOW 32° F (0° C)
360 Cold Cranking Amps (Approx. 70 amp/hour)	450 Cold Cranking Amps (Approx. 95 amp/hour)

Battery Compartment

Mount the battery in its own compartment, away from the genset and any spark-producing device. For ventilation, provide the battery compartment with an opening of at least 1.7 in² (11 cm²) at the top and 1.7 in² (11 cm²) at the bottom.

Mount the battery on a rigid support structure, where leaks and accidental spills cannot damage the genset, fuel lines, and wiring.

⚠ WARNING *Batteries present the hazard of explosion, which can result in severe personal injury. Because batteries give off explosive gas, install the battery in a separate compartment from the genset and away from all flames, pilot light, arcing, or spark-producing devices.*

Battery Cables

Because of the high cranking currents involved, it is highly recommended that a negative (-) battery cable be run with the positive (+) battery cable between the battery and the genset. Size the cables according to Table 8-2. Total cable length is the sum of the lengths of the positive (+) and negative (-) cables. In other words, total cable length will be approximately twice the distance between the battery and the genset.

Alternatively, use rated cranking current as the basis for calculating battery cable size. Rated cranking current for these gensets is 180 amperes at 0° F (-18° C). The cables should be sized so that voltage across the cranking motor terminals will be within 1 volt of the voltage across the battery terminals.

⚠ WARNING *Batteries present the hazard of explosion, which can result in severe personal injury. Because batteries give off explosive gas, always disconnect the negative (-) cable first, and connect it last to reduce the risk of arcing.*

TABLE 8-2. CABLES FOR COLD WEATHER STARTING TO -20° F (-29° C)

*CABLE LENGTH IN FEET (METERS)	CABLE SIZE
0 to 45 (0 to 13.7)	2**
46 to 60 (14 to 18.3)	0
61 to 80 (18.6 to 24.4)	00

* Battery cable lengths are total lengths from the battery to the generator back to the battery and when using a total of 1000CCA (Cold Cranking Amps).

** #2 cable is acceptable up to 20 feet (6.1 m) if the battery capacity exceeds 1000 CCA.

Negative (-) Battery Connection. Connect one end of the negative (-) battery cable to the genset ground. Tighten the ground connection securely (see Figure 8-8).

Alternate Negative (-) Battery Connection. In cases where the distance from the battery to the genset is quite long, the vehicle frame (ground) can be used for the return cranking current:

1. Connect one end of a short, negative (-) battery cable (of the same size as the positive (+) battery cable) to the vehicle frame near the battery. (Do not connect the other end to the battery at this time.)
2. Connect one end of a short, negative (-) battery cable (of the same size as the positive (+) battery cable) to the vehicle frame near the genset. Connect the other end to the genset ground. See Figure 8-8.

NOTE: Make sure that the frame (ground) connections (to major frame members, if possible) are secure enough to minimize electrical resistance. Avoid making these connections at welds or mechanical joints.

Positive (+) Battery Connection. Refer to Figure 8-8 for the following steps:

1. Connect the positive (+) battery cable to the ring on the genset B+ cable ring.
2. Tighten this connection securely.
3. Slide the terminal boot on the genset B+ lead over the connection.
4. Use a tie wrap to hold the terminal boot in place over the connection.

Route battery cables away from fuel lines and hot engine exhaust components. Battery cable should

Genset Bonding Terminal

The genset ground, as shown in Figure 8-8, is also the bonding terminal for grounding the genset to the vehicle frame (ground) when a continuous negative (-) battery cable is used from the battery directly to the genset. Connect an 8 AWG grounding wire from the vehicle frame to the genset ground.

be accessible for inspection and replacement, protected from damage and secured to prevent chafing due to vibration.

⚠ WARNING *Routing battery cables with fuel lines can lead to fire and severe personal injury or death. Keep battery cables away from fuel lines.*

⚠ CAUTION *Failure to secure the battery cable terminals can result in personal injury and/or equipment damage from an electrical short. See that terminal connections are secure. If necessary, secure cables to prevent abrasion.*

NOTE: Make sure that the frame (ground) connections (to major frame members, if possible) are secure enough to minimize electrical resistance. Avoid making these connections at welds or mechanical joints.

⚠ WARNING *Failure to ground the genset properly can result in injury or death. The genset must be grounded to the vehicle frame.*

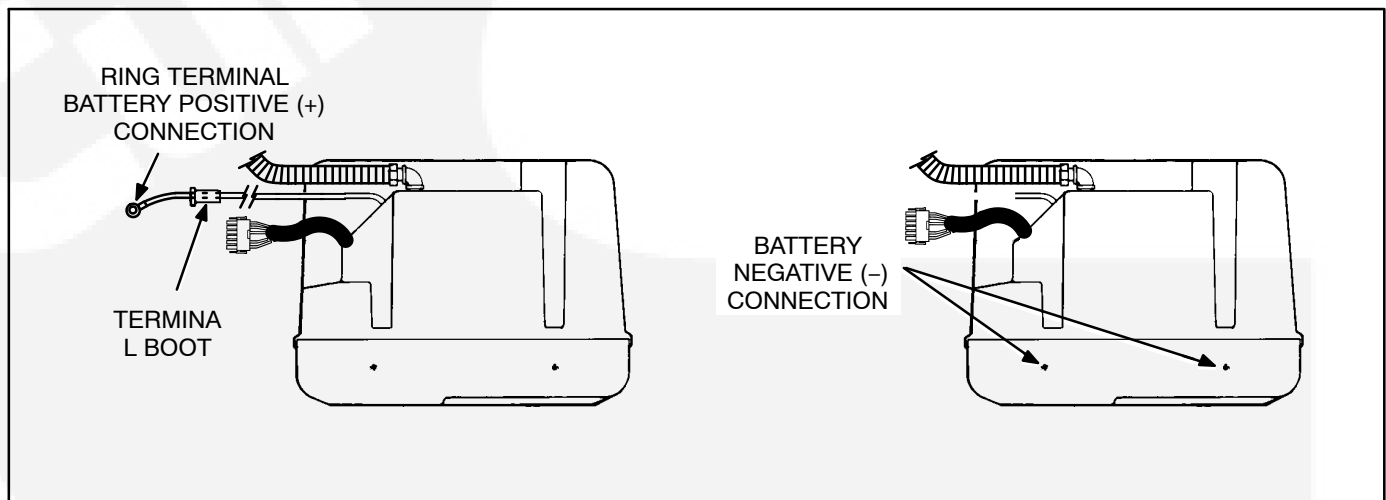

FIGURE 8-8. BATTERY CABLE CONNECTIONS

9. Initial Start and Checks

INSTALLATION REVIEW

Prior to initial start up of the genset, check (✓) each of the following items. For a safe and effective installation, each answer must be yes: if not, that aspect of the installation should be reworked or provision made to satisfy the requirement.

- If installed in a compartment, is the compartment metal-lined and sealed around all edges?
- Are wiring holes into the inside of coach (including the inside of AC conduit) sealed to prevent passage of exhaust gases?
- Can the following routine maintenance items be performed through the service access panel? Refer to Figure 3-3.
 - Change oil
 - Adjust carburetor
 - Start/stop the unit
 - Change air filter
 - Governor adjustment
 - Operate AC circuit breaker
 - Change spark plug
- Are air inlet and exhaust openings clear and sufficiently sized (see *Mounting* section) for proper airflow?
- If the installation is for an under-floor kit, is there a metal barrier between the genset and a combustible floor? See Figure 3-8.
- Are fuel lines and electrical wires protected from chafing and damage and are they insulated from each other? Refer to Figure 3-11.
- Are all fuel connections and hose clamps tight? Refer to Figure 3-12.
- Is a flexible section of non-conducting fuel line installed between the fuel inlet and the fuel line from the tank? Refer to Figure 3-12.
- Are all electrical leads connected and protected, and is the conduit adequately supported? Refer to Figures 3-13, 3-14, 3-15 and 3-16.
- Does the exhaust system extend beyond the perimeter of the vehicle a minimum of 1 inch (25 mm)? Refer to Figure 3-18.
- Is the exhaust pipe terminated away from windows, vents, or other openings that might allow exhaust gases to enter, or be pulled in when the vehicle is in motion? Refer to the *Exhaust System* section.
- If the exhaust system is run into the angle of approach or departure (see Figure 6-1), is it protected from bottoming out by use of skid bars, rollers, etc.?
- Is the exhaust system secure and are all connections tight? Are all required exhaust clamps, hangers, and support straps in place per the *Exhaust System* section of this manual and the kit instructions?
- Is the genset protected from direct road splash from vehicle wheels?
- Has a rubber boot been installed on battery positive (+) lead at the connection? Refer to Figure 3-14.
- Has the crankcase oil been checked and is the oil level and weight correct? Refer to the *Maintenance* section of the Operator's manual.

⚠ WARNING

EXHAUST GAS IS DEADLY!

Exhaust gases contain carbon monoxide, an odorless and colorless gas. Carbon monoxide is poisonous and can cause unconsciousness and death. Symptoms of carbon monoxide poisoning can include:

- **Dizziness**
- **Nausea**
- **Headache**
- **Weakness and Sleepiness**
- **Throbbing in Temples**
- **Muscular Twitching**
- **Vomiting**
- **Inability to Think Coherently**

IF YOU OR ANYONE ELSE EXPERIENCE ANY OF THESE SYMPTOMS, GET OUT INTO THE FRESH AIR IMMEDIATELY. If symptoms persist, seek medical attention. Shut down the unit and do not operate until it has been inspected and repaired.

Never occupy the vehicle with the generator set running unless the vehicle interior is equipped with an operating carbon monoxide detector. Protection against carbon monoxide inhalation also includes proper exhaust system installation and visual and audible inspection of the complete exhaust system at the start of each generator set operation.

PRE-START CHECKS

Before starting the genset, perform these steps:

1. Check the engine oil level. Remove and clean the oil level indicator. Insert the oil level indicator into the oil filler neck. It is not necessary to screw the oil level indicator in to obtain an oil level reading.

If low, add oil very slowly until the Full mark is reached. Screw the oil level indicator into the filler neck securely to prevent oil leakage.

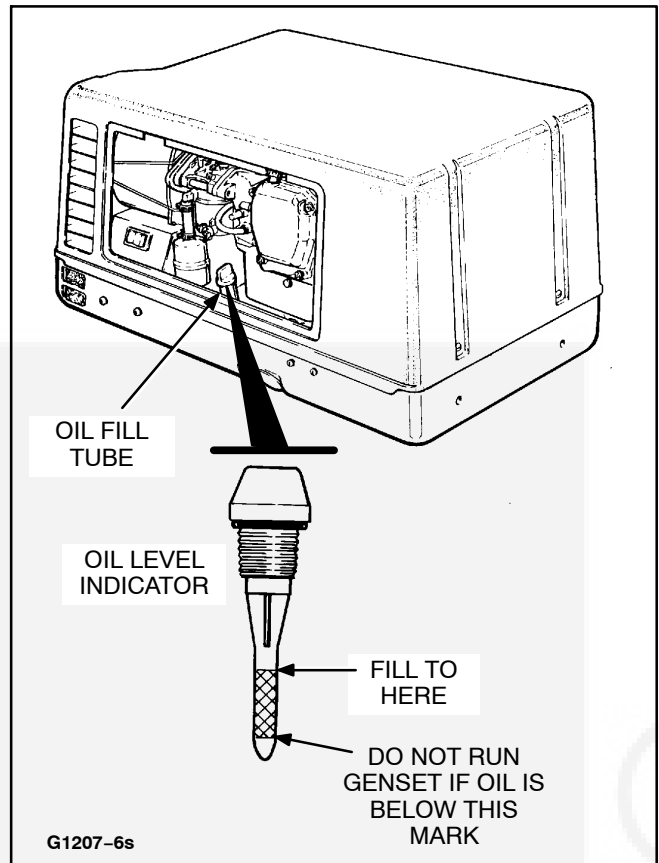

FIGURE 9-1. OIL LEVEL INDICATOR

2. Check that battery terminals and cable connectors are clean and dry. Connect the positive (+) battery cable to the POS (+) battery post first, then connect the negative (-) battery cable to the NEG (-) battery post. Always connect the negative (-) battery cable last to reduce the risk of arcing.

⚠WARNING *Batteries present the hazard of explosion, which can result in severe personal injury. Because batteries produce explosive gas, do not smoke or allow any arc-producing devices in the battery area. Do not disconnect cables from the battery while the genset is cranking or running. This causes arcing and can result in an explosion.*

3. See the Operator's Manual, and note the features of the genset. Open the fuel supply valve to the genset (if equipped).

INITIAL STARTING AND CHECKS

⚠WARNING *Exhaust gas presents the hazard of severe personal injury or death. Do not operate the genset inside any room or building.*

Starting from the Set Mounted Control

1. Push the Start/Stop switch to the START position. The engine should crank and start. The unit may need more cranking at initial start than at subsequent starts, to prime the fuel system. If the genset fails to start, see the *Troubleshooting Guide* in the Operator's Manual.
2. After the set starts, check for fuel leaks. If any leaks are found, stop the set immediately, close the fuel supply and have the leak(s) repaired. Make sure that the fuel line does not touch anything that can damage it.

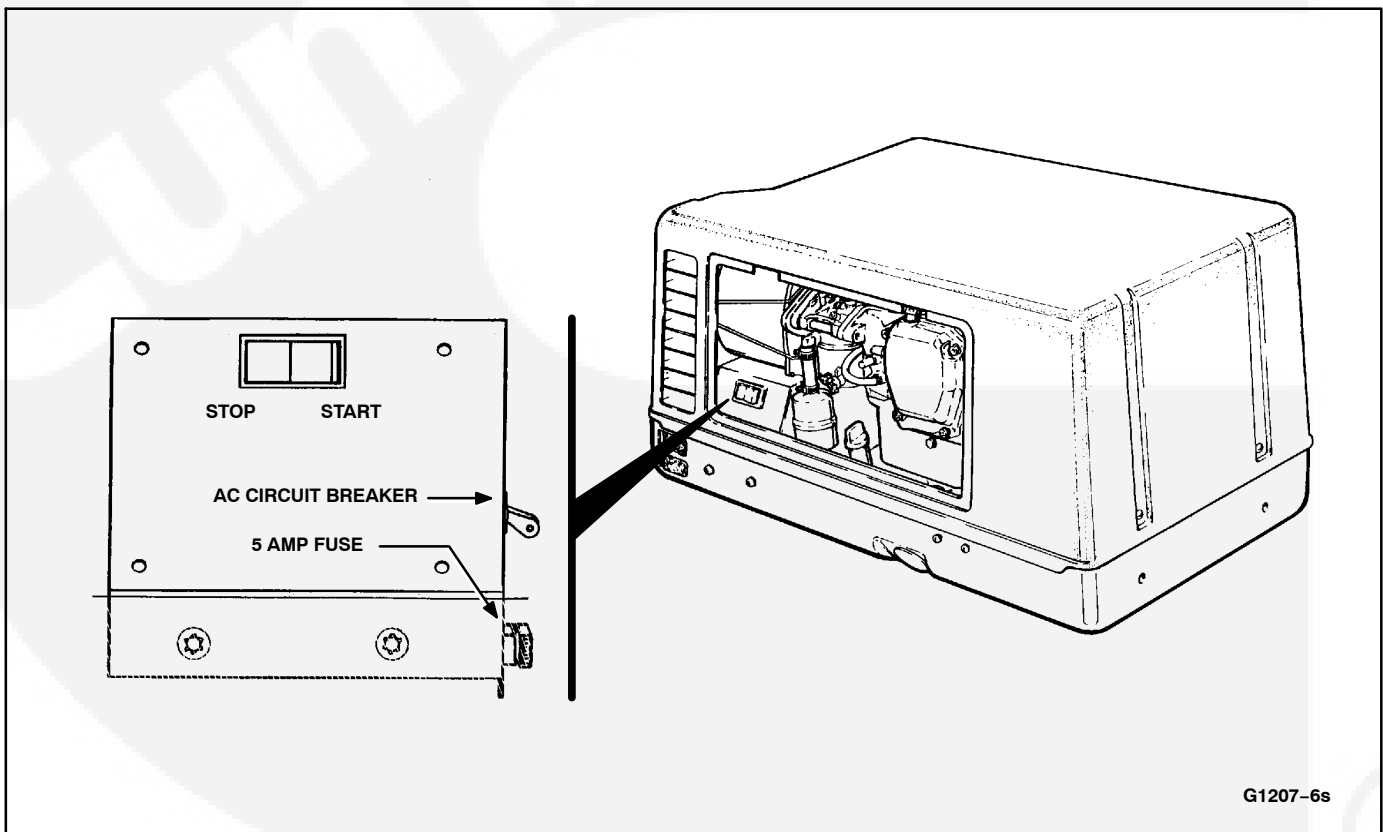

FIGURE 9-2. STANDARD CONTROL PANEL

⚠WARNING *Fuel presents the hazard of explosion or fire that can result in severe personal injury or death. If a fuel leak is found, stop the genset, and have the leak repaired immediately.*

⚠WARNING *A hot genset can cause severe burns. Always allow the genset to cool before performing service.*

3. Examine the exhaust system for leaks. If any leaks are found, stop the set and have the exhaust system repaired immediately.

⚠WARNING *Exhaust gas presents the hazard of severe personal injury or death. Inspect the exhaust system audibly and visually. With the genset running, momentarily open the access cover to inspect the muffler. Do not operate the genset if it is excessively noisy. Have any leaks repaired immediately.*

4. Operate the set with a normal load, monitoring fuel supply connections, exhaust system, set performance, and amount of noise reduction. If set performance is not acceptable, see the Service Manual for adjustment procedures, or con-

tact an authorized Onan service center for assistance. If the generator set requires adjustment or repair, disconnect the starting battery, negative (-) cable first, to prevent accidental start-up.

⚠WARNING *Accidental starting of the genset during maintenance procedures can cause severe personal injury or death. Disconnect the genset starting battery, negative (-) cable first, before performing maintenance.*

5. Push the Start/Stop switch to the STOP position to stop the genset.

Starting from the Remote Control

1. Push the remote Start/Stop switch to the START position. The engine should crank and start. If it does not, see the *Troubleshooting Guide* in the Operator's Manual. Check all remote control connections, repair if necessary, and restart the set.
2. After the genset starts, check the battery condition meter (if equipped) to confirm its operation.
3. Push the Start/Stop switch to the STOP position to stop the generator set.



Cummins **Onan**

Cummins Power Generation

1400 73rd Ave. NE
Minneapolis, MN 55432 USA

Phone 1 763 574 5000

Toll-free 1 800 888 6626

Fax 1 763 574 5298

Email www.cumminsonan.com/contact

www.cumminsonan.com

Cummins®, Onan®, the "C" logo, and "Performance you rely on." are trademarks of Cummins Inc.

©2012 Cummins Power Generation, Inc. All rights reserved.

